

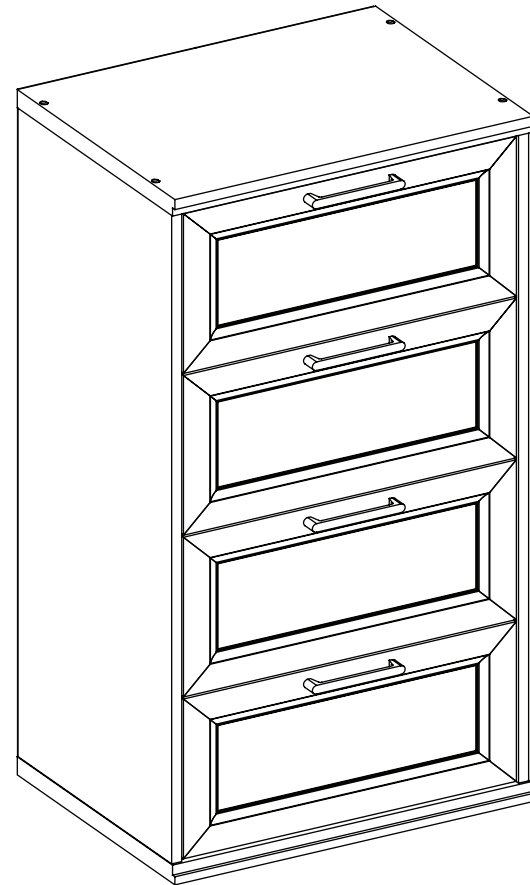

STYLE SELECTIONS is a trademark or registered trademark of LF, LLC. All rights reserved.



ITEM #5120854

DRAWER STORAGE

MODEL #LWSCDS

! WARNING

Please read and understand this entire manual before attempting to assemble, operate or install the product.

**UNIT MUST BE PERMANENTLY FASTENED TO THE WALL WITH PROVIDED HARDWARE;
THIS STORAGE UNIT IS NOT DESIGNED OR INTENDED FOR FREESTANDING USE.**

ATTACH YOUR RECEIPT HERE

Serial Number _____ Purchase Date _____

Français p. 14

Español p. 27



Questions? Call customer service at 1-877-888-8225, 8 a.m. - 8 p.m., EST, Monday - Sunday.

PACKAGE CONTENTS

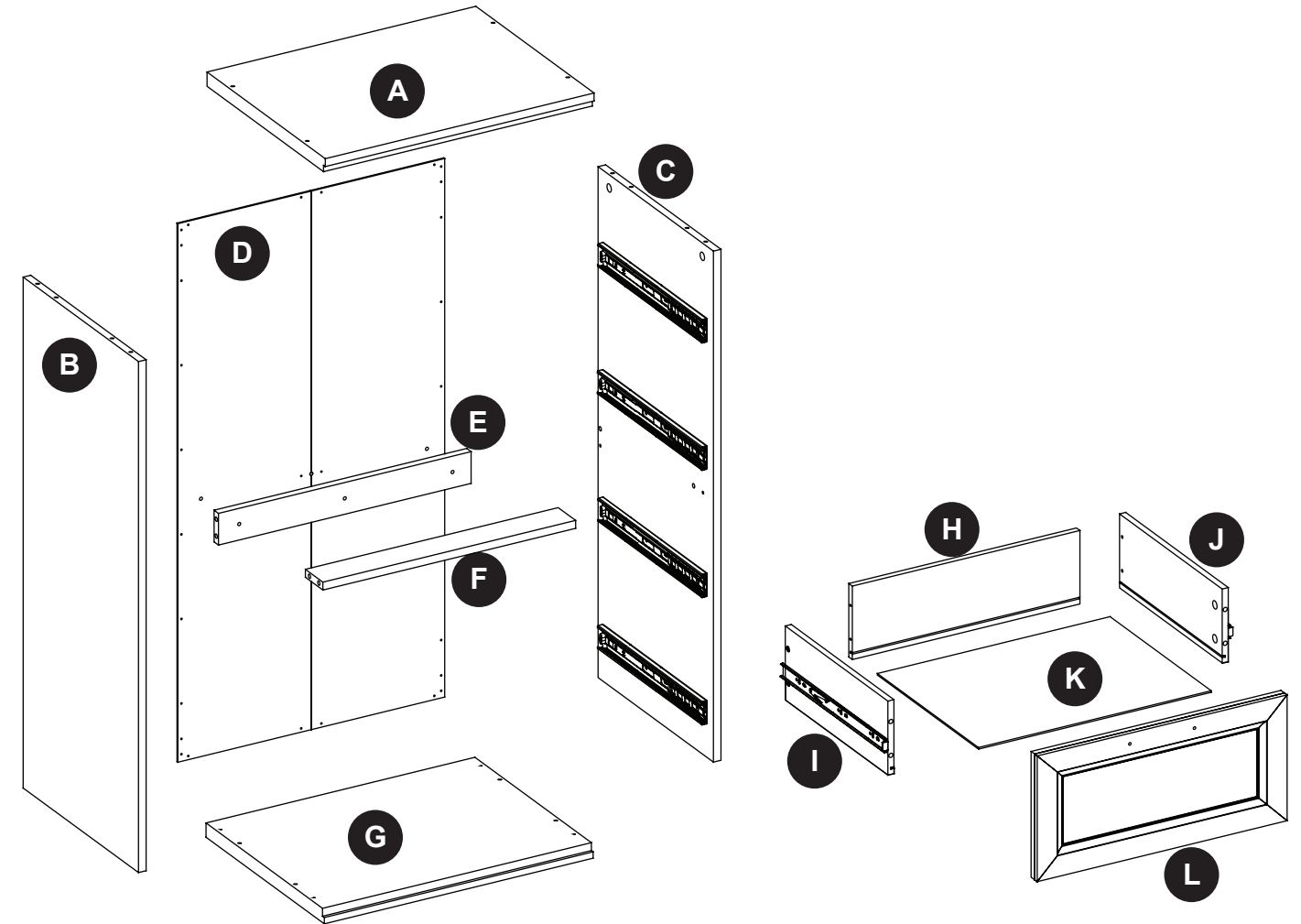



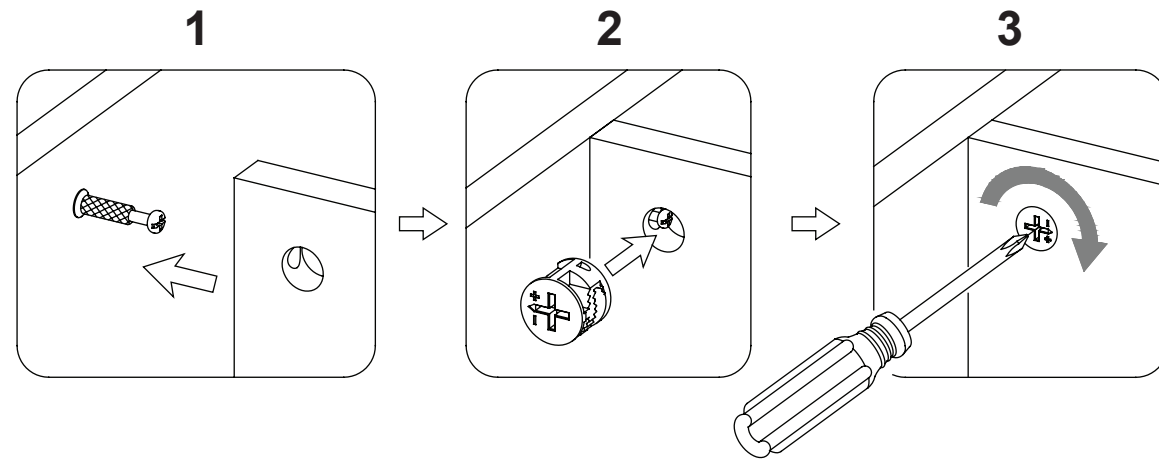

PART	DESCRIPTION	QUANTITY	PART	DESCRIPTION	QUANTITY
A	Top Panel	1	G	Bottom Panel	1
B	Side Panel Left	1	H	Drawer Back	4
C	Side Panel Right	1	I	Drawer Left	4
D	Back Panel	1	J	Drawer Right	4
E	Back Stretcher	1	K	Drawer Bottom	4
F	Front Stretcher	1	L	Drawer Front	4

CAM LOCK SYSTEM OPERATION



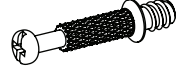
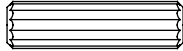
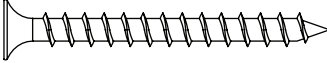
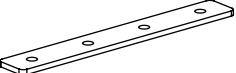

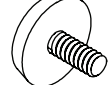

1. Screw the Cam Bolt into the pre-drilled small holes on the panel. Connect both panels together; making sure the Cam Bolt goes into the pre-drilled hole at the end of the panel with the Cam Lock.
2. Insert the Cam Lock into the pre-drilled large hole in the panel. Make sure the arrow on the Cam Lock is pointed towards the Cam Bolt.
3. Once the Cam Bolt is connected inside the Cam Lock, take a Phillips screwdriver (not included) and tighten the Cam Lock clockwise.

HARDWARE CONTENTS (not shown actual size)

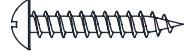
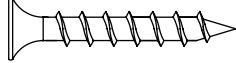
AA 	BB 	CC 	DD 
Cam Lock Qty. 8	Cam Bolt Qty. 24	Wood Dowel Qty. 16	M4 x 50 mm Screw Qty. 4
EE 	FF 	GG 	HH 
Metal Plate Qty. 1	M3.5 x 15 mm Screw Qty. 22	Floor Leveler Qty. 4	Cap Qty. 4

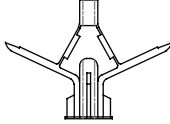
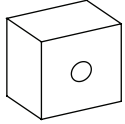
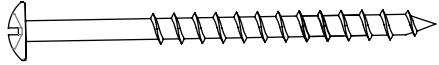
HARDWARE CONTENTS (not shown actual size)

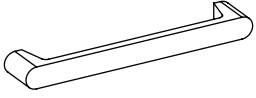
II 	JJ 	KK 	LL 
Plastic Cover Qty. 20	M3.5 x 19 mm Screw Qty. 4	M4 x 38 mm Screw Qty. 16	Small Cam Lock Qty. 16
MM 	NN 	OO 	PP 
Drywall Anchor Qty. 3	Back Crosser Qty. 3	M5 x 65 mm Screw Qty. 3	5/32" x 25 mm Bolt Qty. 8
QQ 			
Handle Qty. 4			

! SAFETY INFORMATION

Please read and understand this entire manual before attempting to assemble, operate or install the product.

Please read and understand this entire manual prior to assembling the product.

1. Do not allow children to climb or play in or around this product.
2. Use this unit for its intended purpose only. Do not use shelves as step ladder.
3. To avoid damage, assemble the product on a sturdy, level and protective surface.
4. Make sure all bolts/screws are tightly fastened before the unit is used.
5. Check bolts/screws periodically and tighten them if necessary.
6. **Unit must be permanently fastened to the wall with provided hardware; this storage unit is not designed or intended for freestanding use.**

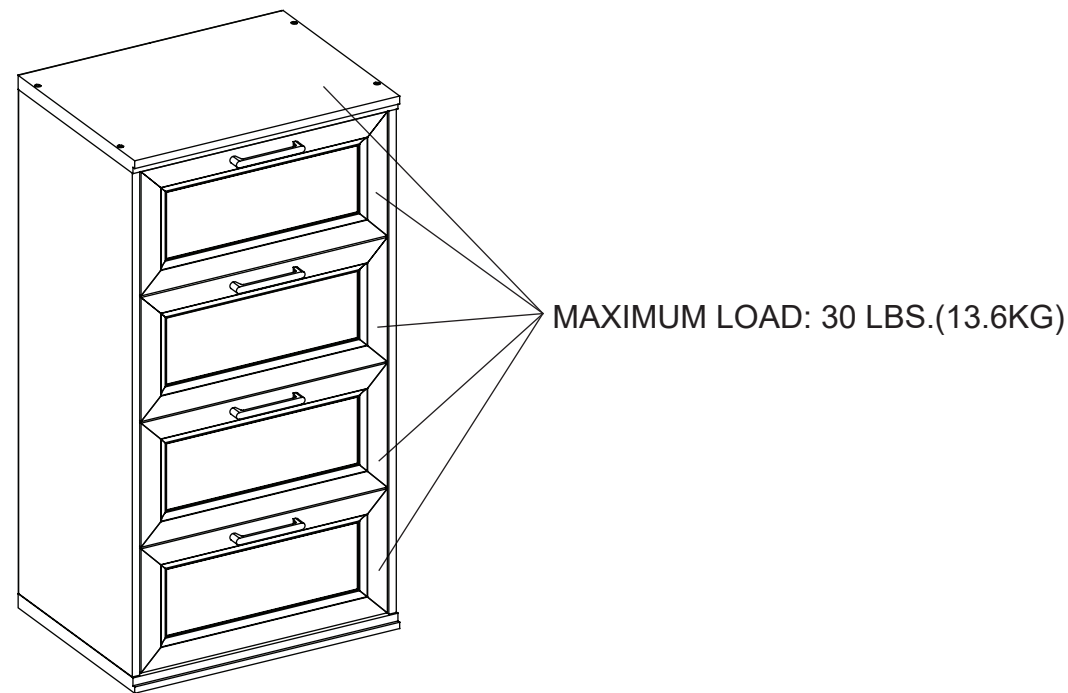

! WARNING

UNIT IS INTENDED FOR USE ONLY WITH MAXIMUM WEIGHTS INDICATED. OVERLOADING STORAGE UNIT WITH PRODUCTS HEAVIER THAN MAXIMUM WEIGHT MAY RESULT IN INJURY. DISTRIBUTE ANY WEIGHT IN UNITS EVENLY.

PREPARATION

Before beginning assembly of product, make sure all parts are present. Compare parts with package contents list and hardware contents list. If any part is missing or damaged, do not attempt to assemble the product.

Estimated Assembly Time: 50 minutes

Tools Required for Assembly (not included): Rubber Mallet, Phillips screwdriver.

ASSEMBLY INSTRUCTIONS

1. Attach drawer left (I) and drawer right (J) to drawer back (H) using M4 x 38 mm screws (KK).

Hardware Used

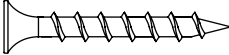
KK M4 x 38 mm Screw  x 16

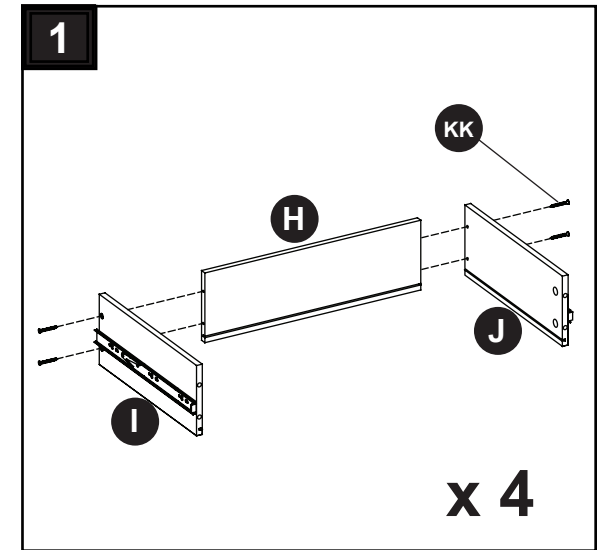

2. Insert drawer bottom (K) into drawer left (I), drawer right (J) and drawer back (H).

Hardware Used

BB Cam Bolt  x 16

PP 5/32" x 25 mm Bolt  x 8

QQ Handle  x 4

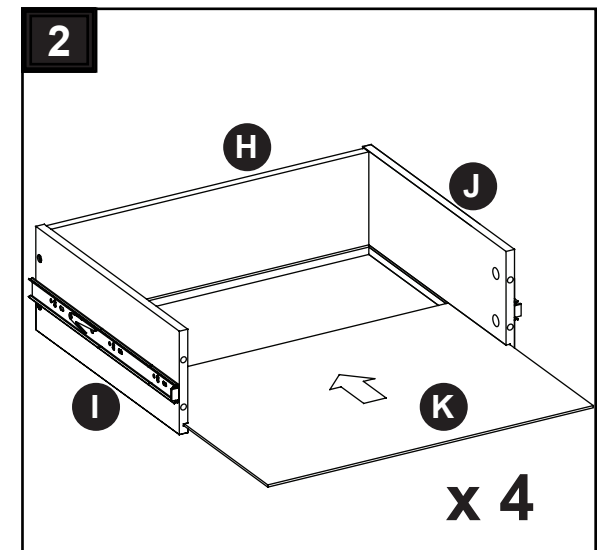

3. Insert cam bolts (BB) into drawer front (L). Attach a handle (QQ) to the front side of drawer (L) using the 5/32" x 25 mm bolts (PP) provided.

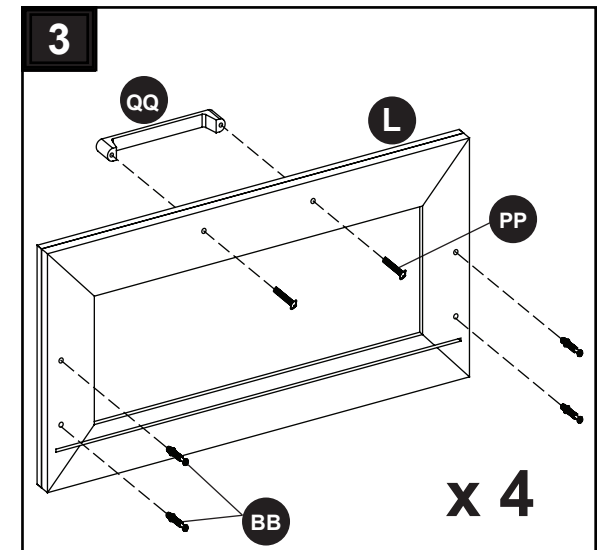



ASSEMBLY INSTRUCTIONS

4. Attach drawer front (L) to drawer left (I), drawer right (J) using small cam locks (LL).

Plug Plastic Covers (II) to cover the small cam locks for nice looking.

Repeat previous steps to attach other three drawers.

Hardware Used

LL	Small Cam Lock		x 16
II	Plastic Cover		x 16

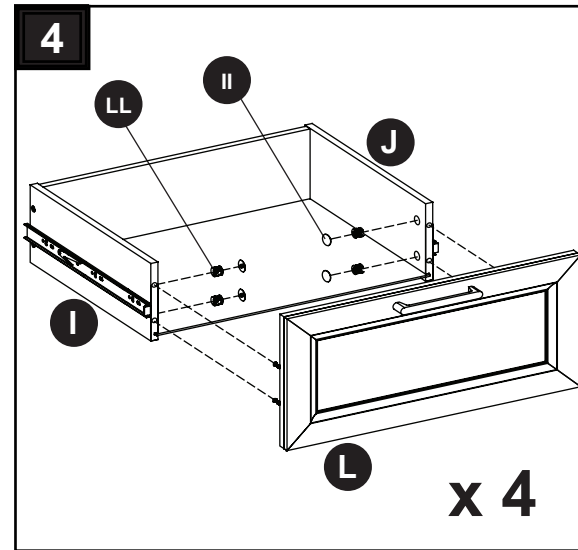

5. Install cam bolts (BB) and wood dowels (CC) into pre-drilled holes on side panel left (B) & side panel right (C) and make sure they are completely seated, attach back stretcher (E) & front stretchers (F) to side panel left (B) and side panel right (C) by cam locks (AA) as shown in figure.

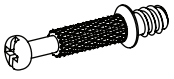
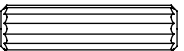

Hardware Used

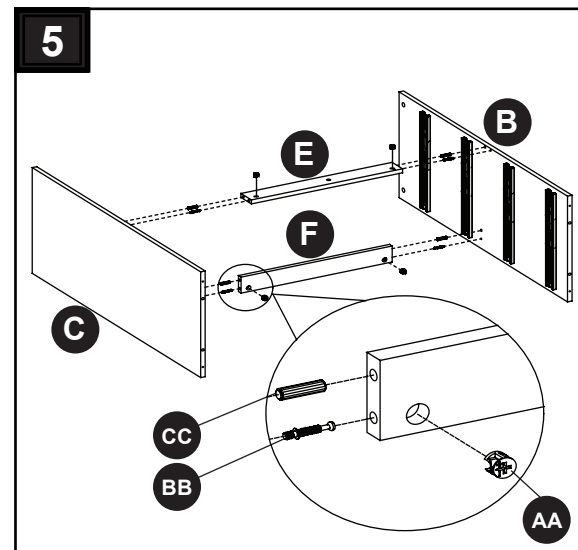
AA	Cam Lock		x 4
BB	Cam Bolt		x 4
CC	Wood Dowel		x 4

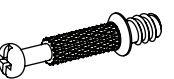

6. Insert the cam bolts (BB) and wood dowels (CC) into pre-drilled holes on top panel (A), Position the top panel (A) onto the side panel left (B) and side panel right (C) by cam locks (AA) as shown in figure.

Hardware Used

AA	Cam Lock		x 4
BB	Cam Bolt		x 4
CC	Wood Dowel		x 4

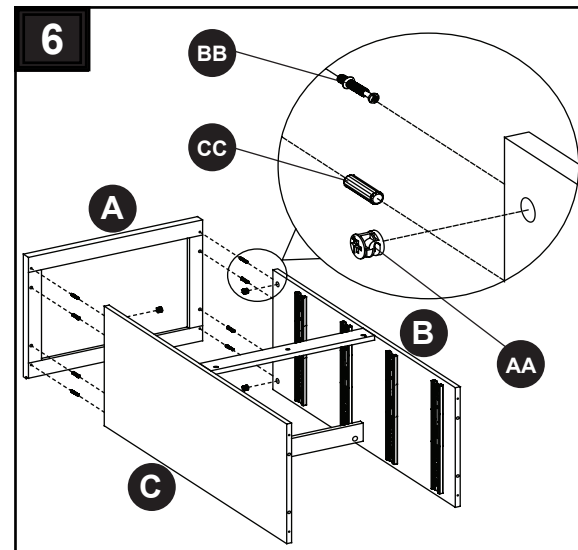

ASSEMBLY INSTRUCTIONS

7. Insert wood dowels (CC) into bottom panel (G). Attach bottom panel (G) to side panel left (B) & side panel right (C) securing with M4 x 50 mm screws (DD).

Hardware Used

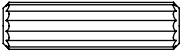
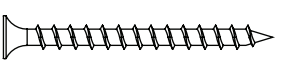
CC	Wood Dowel		x 4
DD	M4 x 50 mm Screw		x 4

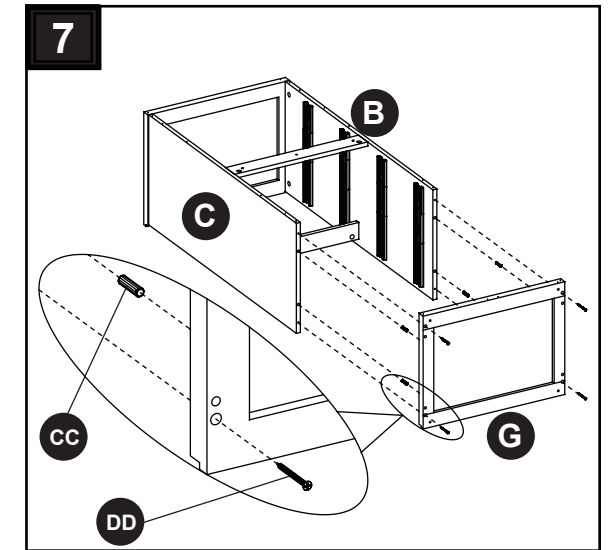

8. Expand the back panel (D) and lay it onto the back edges of assembled frame making sure the margins along all edges are equal. Attach the back panel in place by using M3.5 x 15 mm screws (FF) through the pre-drilled holes of back panel.

Hardware Used

FF	M3.5 x 15 mm Screw		x 22
-----------	--------------------	---	------

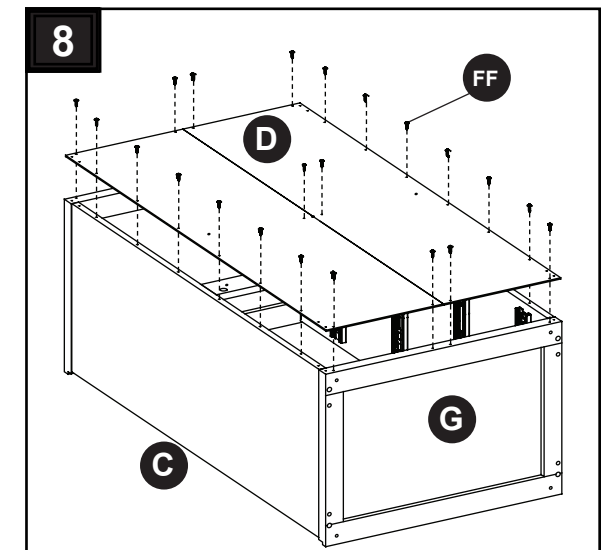

9. Insert floor levelers (GG) into the bottom of bottom panel (G).

Hardware Used

GG	Floor Leveler		x 4
-----------	---------------	---	-----

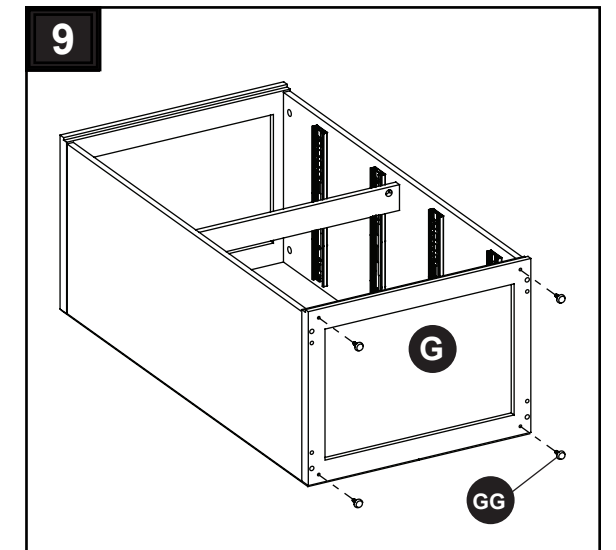

ASSEMBLY INSTRUCTIONS



10.

- a. Adjust floor levelers to level the unit against the wall where desired.
- b. Using back stretcher (E) as a template, mark three holes to indicate where holes will be drilled.
- c. Drill three pilot holes into the wall where previously marked.
- d. Make sure that the drilled holes fit the wall anchors properly.
- e. Press the anchors into the holes and gently tap with a hammer until flush in the holes. PLEASE NOTE: If the mounting hole coincides with a wooden stud, there is no need for a wall anchor.
- f. Align back stretcher (E) and back crossers (NN) over the drywall anchors (MM) and secure with M5 x 65 mm screw (OO).
- g. Tighten screws securely with Phillips screwdriver.

If you want this unit flush against the wall, you can cut away the baseboard of the wall, and then secure with M5 x 65 mm screw (OO) without back crosser (NN).

Plug Plastic covers (II) to cover the cam locks for aesthetic purposes.

Hardware Used

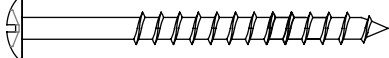
II	Plastic Cover		x 4
MM	Drywall Anchor		x 3
NN	Back Crosser		x 3
OO	M5 x 65 mm Screw		x 3

11. Drawer installation

- 1a. Extend the ball bearing slide tracks on the unit all the way forward (including ball bearing cart).
- 1b. Align the slide runners on the assembled drawers with the slide tracks and push the drawer carefully inside until it stops.

NOTE: If the drawer does not go in smoothly, please take it out and repeat the step. If you need to remove the drawer, please pull the drawer all the way out, then simultaneously push the plastic release lever of the ball bearing slides up on one side and down on the other side, and then pull it completely out.

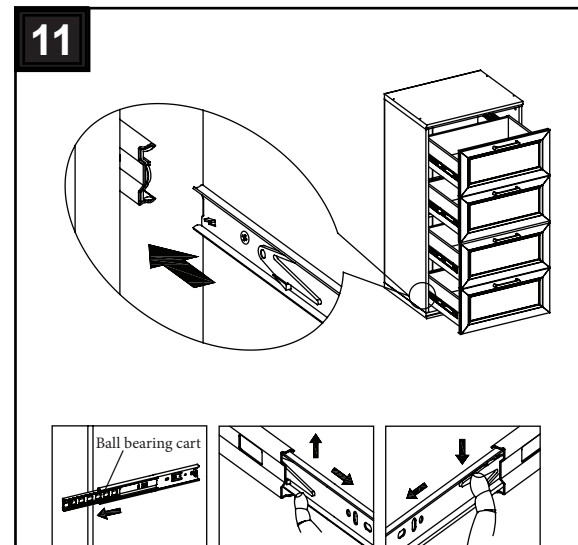
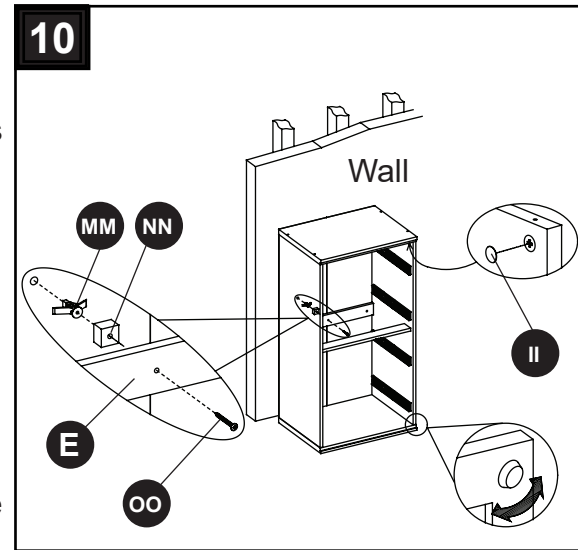



ASSEMBLY INSTRUCTIONS

12. This cabinet was designed with a feature that allows stacking two units. Additional units sold separately. Insert wood dowels (CC) into the holes on top of the base unit. Place bottom of second unit onto the inserted dowels. Secure units together by attaching the metal plates (EE) at both ends with the M3.5 x 19 mm screws (JJ) into the predrilled holes. If you plan to use this unit as hutch (stand this on another one), please skip step 9 & 13.

NOTE: Remove caps (HH) before stacking two units together.

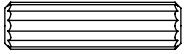
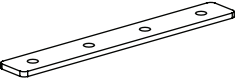
Hardware Used

CC	Wood Dowel		x 4
EE	Metal Plate		x 1
JJ	M3.5 x 19 mm Screw		x 4

13. Insert the caps (HH) into the holes on top of the top panel (A).

Hardware Used

HH	Cap		x 4
-----------	-----	---	-----

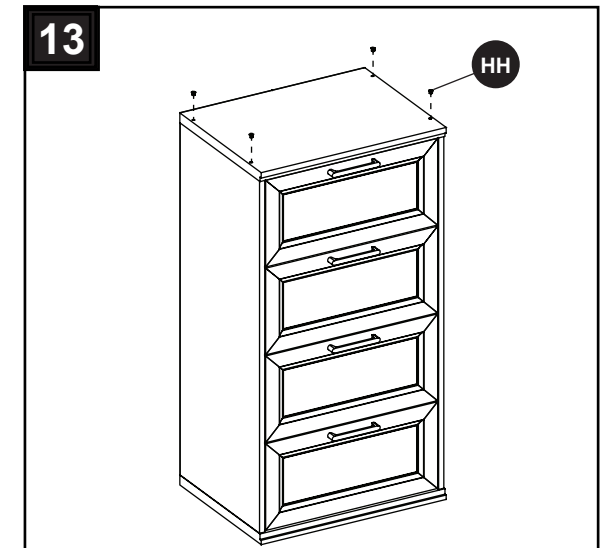
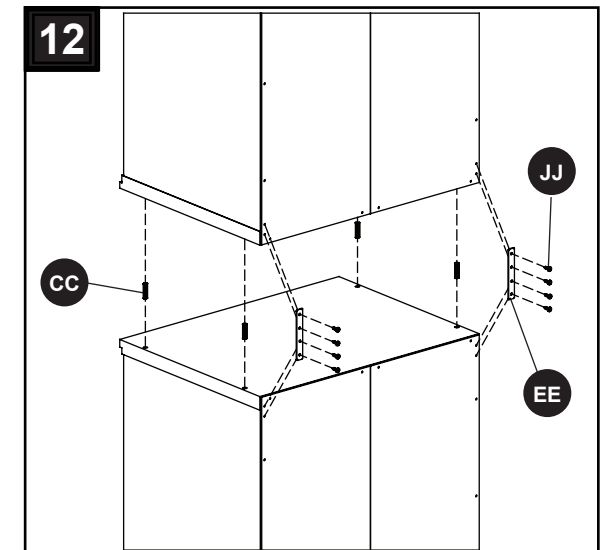

CARE AND MAINTENANCE

- Periodically check to make certain all components are properly positioned, free from damage and firmly connected.
- Use a soft, clean cloth that will not scratch the surface when dusting.
- Never use water to clean the furniture as it may cause damage to the finish.
- Wipe clean using a damp cloth and a mild cleaner. Wipe dry with a clean cloth.
- In the event that the furniture is stained or otherwise damaged during use, it is recommended you call a professional to repair the furniture.
- Keep furniture away from direct sunlight as it may damage the finish.
- It is best to keep the furniture in a climate-controlled environment. Extreme temperature and humidity changes can cause fading, warping, shrinking and splitting of wood.

LIMITED LIFETIME WARRANTY

This product is warranted to the original purchaser. If there is a failure in this unit due to defects in materials or workmanship, the manufacturer will repair or replace this item at our discretion without charge. Warranty is void if product has been assembled incorrectly, misused, abused by overloading, altered in any way or damaged due to accident. This warranty is not transferable and does not cover chipping, flaking, scratches, rust, dents, or other damages to the surfaces of this product. Responsibility of the manufacturer is limited to repair or replacement of this product. The manufacturer is not responsible for consequential, incidental, or other damages or losses resulting from product failure.

This warranty is in lieu of all other expressed warranties. Some states do not allow the exclusion or limitation of incidental or consequential damages, so the above limitation may not apply to you. This warranty gives you specific legal rights and you may have other rights which vary from state to state.

REPLACEMENT PARTS LIST

For replacement parts, call our customer service department at 1-877-888-8225, 8 a.m. - 8 p.m., EST, Monday - Sunday.

PART	DESCRIPTION	PART #
A	Top Panel	00LWSCDS-A
B	Side Panel Left	00LWSCDS-B
C	Side Panel Right	00LWSCDS-C
D	Back Panel	00LWSCDS-D
E	Back Stretcher	00LWSCDS-E
F	Front Stretcher	00LWSCDS-F
G	Bottom panel	00LWSCDS-G
H	Drawer Back	00LWSCDS-H
I	Drawer Left	00LWSCDS-I
J	Drawer Right	00LWSCDS-J
K	Drawer Bottom	00LWSCDS-K
L	Drawer Front	00LWSCDS-L

REPLACEMENT PARTS LIST

For replacement parts, call our customer service department at 1-877-888-8225, 8 a.m. - 8 p.m., EST, Monday - Sunday.

PART	DESCRIPTION	PART #
AA	Cam Lock	00LWSCDS-AA
BB	Cam Bolt	00LWSCDS-BB
CC	Wood Dowel	00LWSCDS-CC
DD	M4 x 50 mm Screw	00LWSCDS-DD
EE	Metal Plate	00LWSCDS-EE
FF	M3.5 x 15 mm Screw	00LWSCDS-FF
GG	Floor Leveler	00LWSCDS-GG
HH	Cap	00LWSCDS-HH
II	Plastic Cover	00LWSCDS-II
JJ	M3.5 x 19 mm Screw	00LWSCDS-JJ
KK	M4 x 38 mm Screw	00LWSCDS-KK
LL	Small Cam Lock	00LWSCDS-LL
MM	Drywall Anchor	00LWSCDS-MM
NN	Back Crosser	00LWSCDS-NN
OO	M5 x 65 mm Screw	00LWSCDS-OO
PP	5/32" x 25 mm Bolt	00LWSCDS-PP
QQ	Handle	00LWSCDS-QQ
RR	Drawer Slide	00LWSCDS-RR
CH	Complete Hardware	00LWSCDS-CH

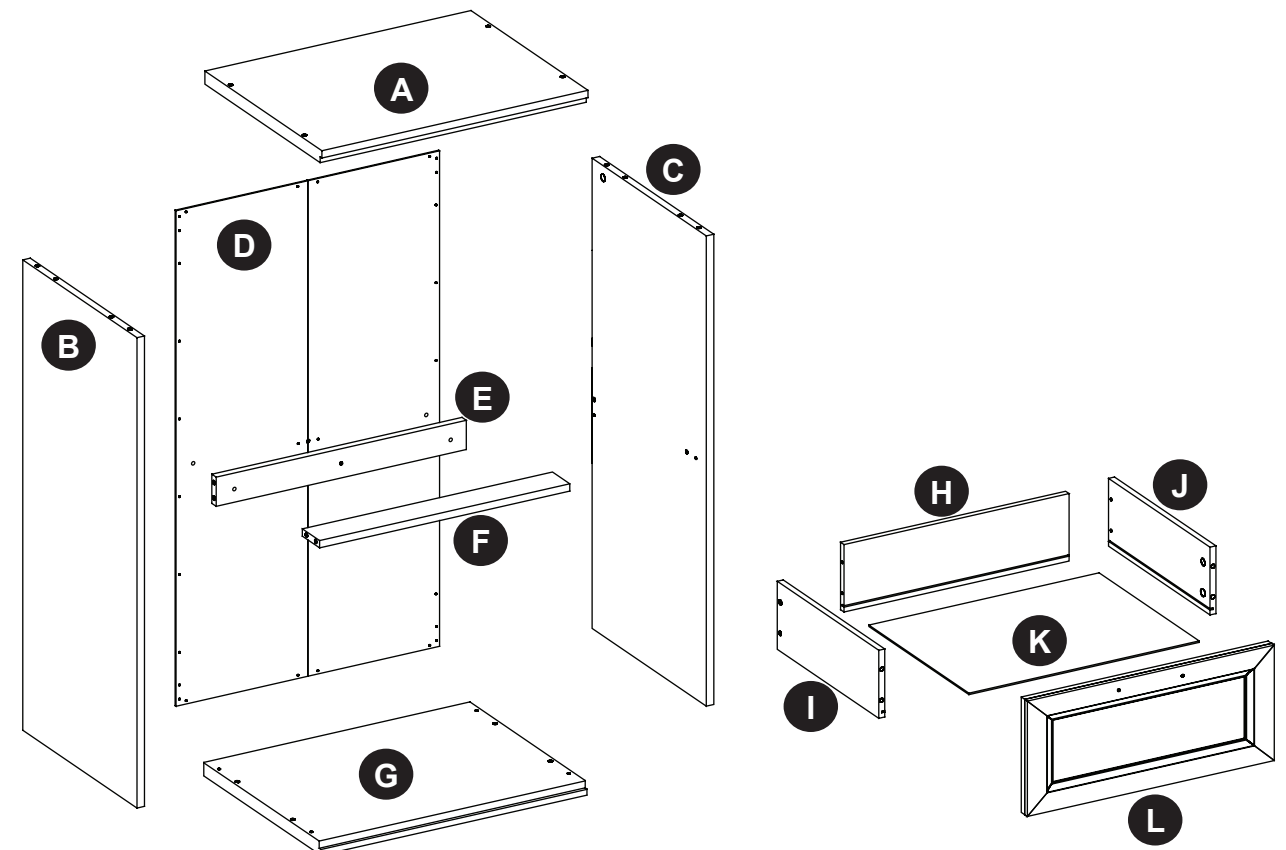

REPLACEMENT PARTS LIST

For replacement parts, call our customer service department at 1-877-888-8225, 8 a.m. - 8 p.m., EST, Monday - Sunday

AA



BB

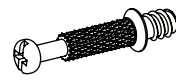

CC



DD

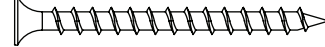

EE

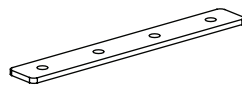

FF



GG

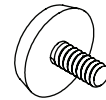

HH



II

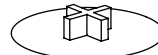

JJ



KK

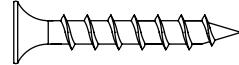

LL



MM

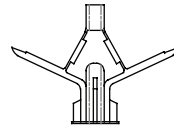

NN

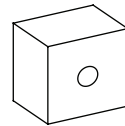

OO



PP



QQ

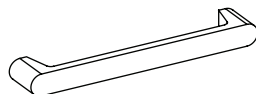

RR

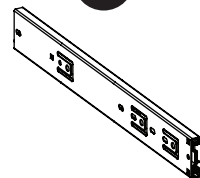

STYLE SELECTIONS est une marque commerciale ou une marque déposée de LF, LLC, tous droits réservés.

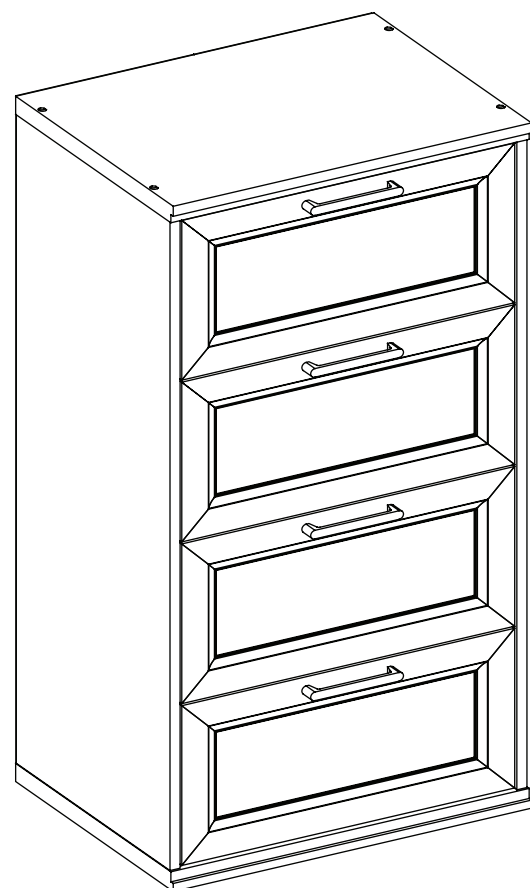

ARTICLE # 5120854

RANGEMENT À TIROIRS

MODÈLE # LWSCDS

⚠ AVERTISSEMENT

Assurez-vous de lire et de comprendre l'intégralité du présent manuel avant de tenter d'assembler, d'utiliser ou d'installer l'article.

L'ÉLÉMENT DOIT ÊTRE FIXÉ EN PERMANENCE AU MUR AVEC LE MATÉRIEL FOURNI;
CET ÉLÉMENT DE STOCKAGE N'EST PAS CONÇU OU DESTINÉ À UNE UTILISATION AUTONOME.

JOIGNEZ VOTRE REÇU ICI

Numéro de série _____ Date d'achat _____



Des questions? Appelez notre service à la clientèle au 1-877-888-8225, de 8 h à 20 h, HNE, du lundi au dimanche

CONTENU DE L'EMBALLAGE

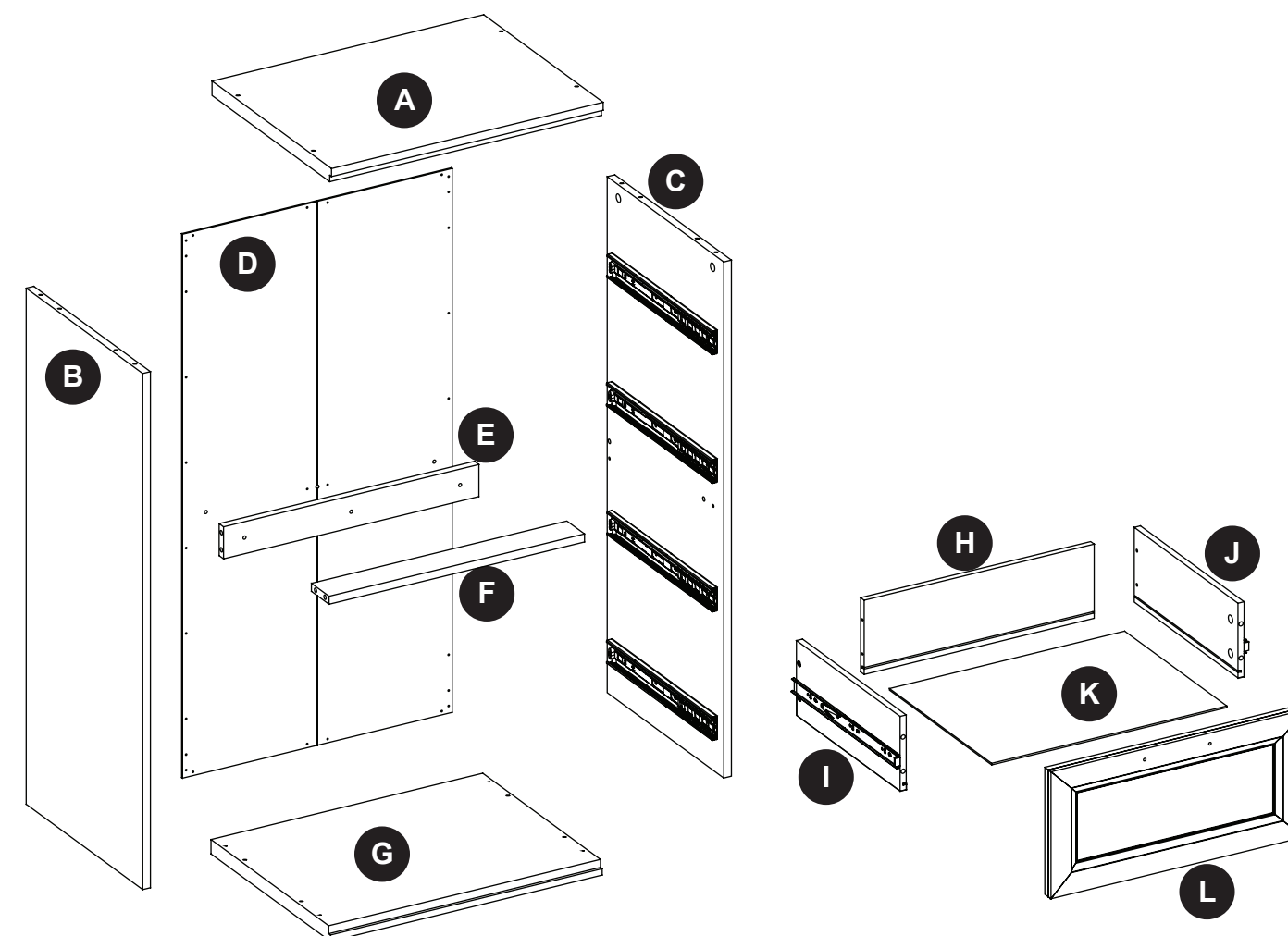

PIÈCE	DESCRIPTION	QUANTITÉ
A	Panneau supérieur	1
B	Panneau latéral gauche	1
C	Panneau latéral droit	1
D	Panneau arrière	1
E	Civière arrière	1
F	Civière avant	1

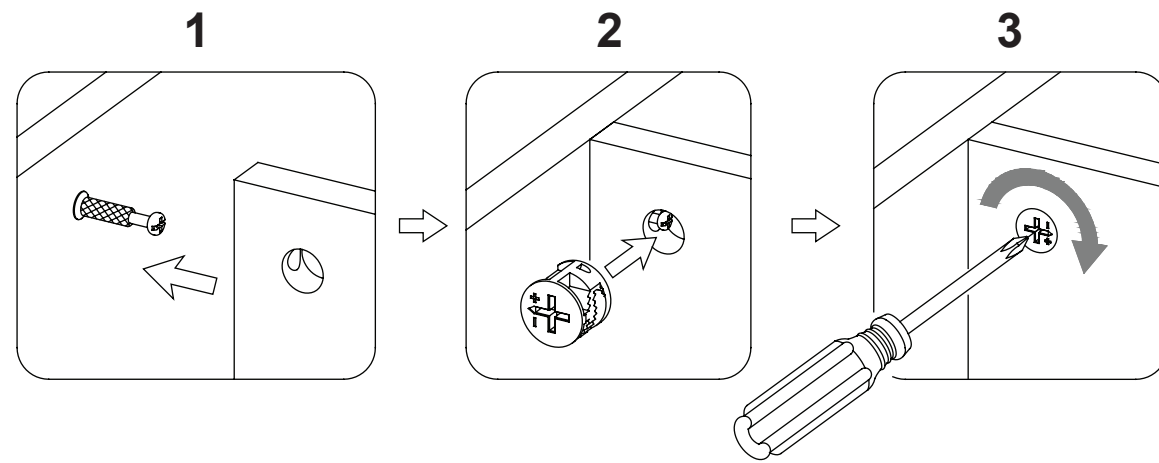

PIÈCE	DESCRIPTION	QUANTITÉ
G	Panneau inférieur	1
H	Tiroir arrière	4
I	Tiroir gauche	4
J	Tiroir droit	4
K	Panneau inférieur du tiroir	4
L	Front du tiroir	4

FONCTIONNEMENT DU SYSTÈME CAMLOC





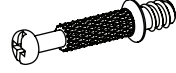
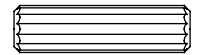
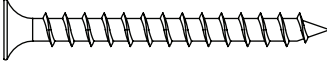
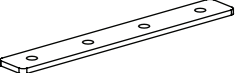

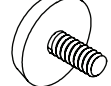
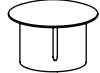

1. Visser un boulon à came dans la douille taraudée sur le panneau. Insérer une came dissimulée dans le trou percé sur le panneau.
2. S'assurer que la flèche sur la came dissimulée soit orientée vers l'entrée du boulon à came.
3. Connecter les deux panneaux en s'assurant que le boulon à came s'insère dans le trou percé à l'extrémité du panneau avec la came dissimulée.

QUINCAILLERIE INCLUSE (non illustrée à la grandeur réelle)

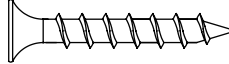
AA 	BB 	CC 	DD 
Attache Camloc Qté. 8	Boulon à came Qté. 24	Goujon de bois Qté. 16	Vis M4 x 50 mm Qté. 4
EE 	FF 	GG 	HH 
Plaque Métallique Qté. 1	Vis M3.5 x 15 mm Qté. 22	Patin réglable Qté. 4	Couvercle Qté. 4

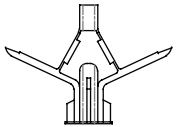
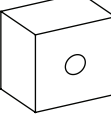
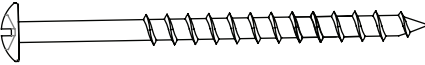
QUINCAILLERIE INCLUSE (non illustrée à la grandeur réelle)

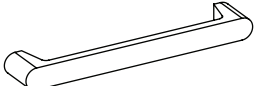
II 	JJ 	KK 	LL 
Couvercle en Plastique Qté. 20	Vis M3.5 x 19 mm Qté. 4	Vis M4 x 38 mm Qté. 16	Petite Attache Camloc Qté. 16
MM 	NN 	OO 	PP 
Cheville d'ancrage Qté. 3	Traverse arrière Qté. 3	Vis M5 x 65 mm Qté. 3	Boulon 5/32" x 25 mm Qté. 8
QQ 			
Poignée Qté. 4			

! CONSIGNES DE SÉCURITÉ

Assurez-vous de lire et de comprendre l'intégralité du présent manuel avant de tenter d'assembler, d'utiliser ou d'installer l'article.

1. Ne laissez pas les enfants grimper ou jouer sur l'article ni autour de celui-ci.
2. Utilisez cet article uniquement pour l'usage auquel il est destiné. N'utilisez pas les tablettes comme s'il s'agissait d'une échelle.
3. Assemblez l'article sur une surface solide, plane et protectrice, pour éviter de l'endommager.
4. Assurez-vous que tous les boulons et toutes les vis sont bien serrés avant d'utiliser l'article.
5. Vérifiez les boulons et les vis régulièrement et serrez-les au besoin.
6. **L'élément doit être fixé en permanence au mur avec le matériel fourni; Cet élément de stockage n'est pas conçu ou destiné à une utilisation autonome.**

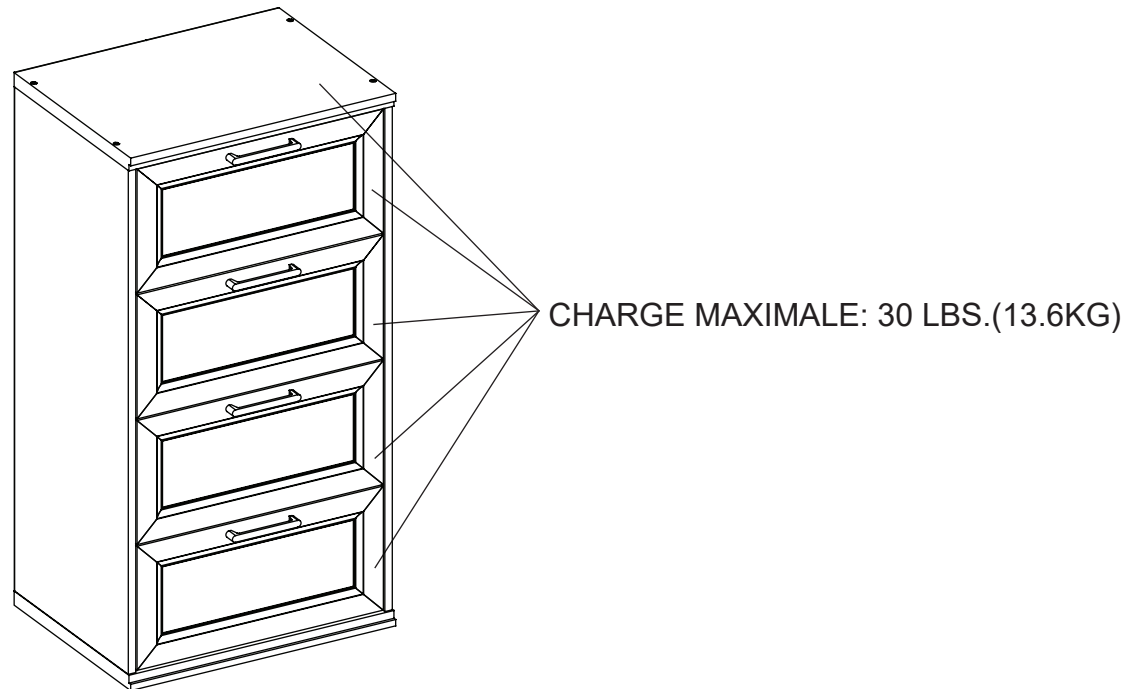

! AVERTISSEMENT

CET ARTICLE NE PEUT SUPPORTER QUE LA CHARGE MAXIMALE INDIQUÉE. L'UTILISATION DE CET ARTICLE AVEC DES PRODUITS DONT LE POIDS DÉPASSE LA CHARGE MAXIMALE INDIQUÉE PEUT ENTRAÎNER DE L'INSTABILITÉ ET CAUSER DES BLESSURES. RÉPARTISSEZ LA CHARGE DE FAÇON UNIFORME.

PRÉPARATION

Avant de commencer l'assemblage de l'article, assurez-vous d'avoir toutes les pièces. Comparez le contenu de l'emballage avec la liste des pièces et celle de la quincaillerie incluse. S'il y a des pièces manquantes ou endommagées, ne tentez pas d'assembler l'article.

Temps d'assemblage approximatif : 50 minutes.

Outils nécessaires pour l'assemblage (non inclus): Marteau en caoutchouc, Tournevis cruciforme.

INSTRUCTIONS POUR L'ASSEMBLAGE

1. Fixer le tiroir gauche (I) et le tiroir droit (J) au tiroir arrière (H), serrer avec les vis M4 x 38 mm (KK).

Quincaillerie Utilisée

KK Vis M4 x 38 mm  x 16

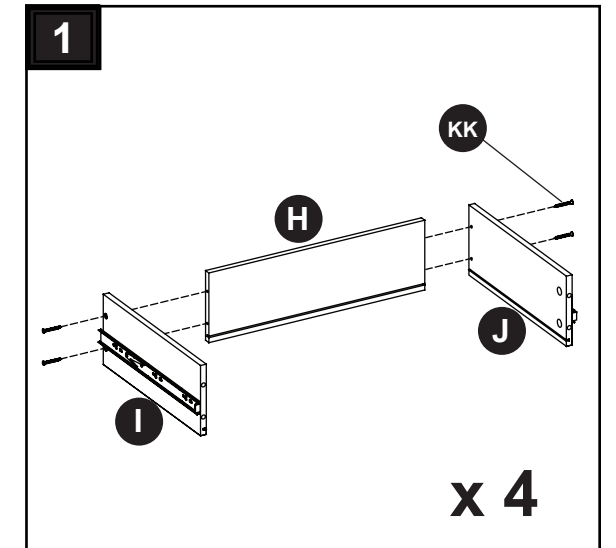

2. Insérer le tiroir bas (K) dans le tiroir gauche (I), le tiroir droit (J) et le tiroir arrière (H).

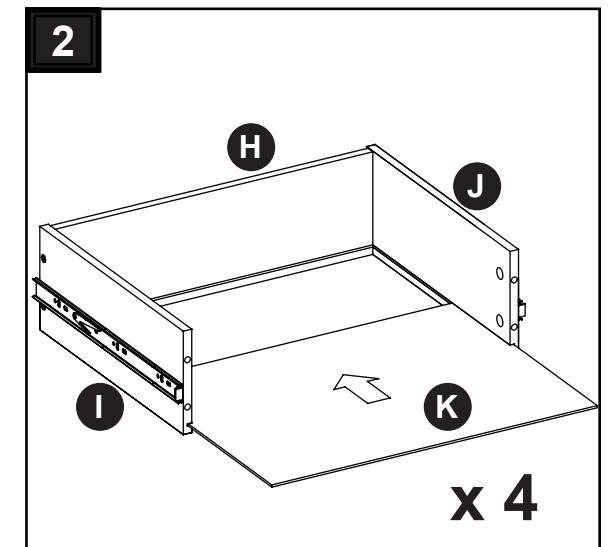

3. Insérez les boulons à came (BB) dans la façade du tiroir (L). Fixez une poignée (QQ) dans la façade du tiroir (L) à l'aide des boulons de 5/32" x 25 mm (PP) fournis.

Quincaillerie Utilisée

BB Boulon à came  x 16

PP Boulon 5/32" x 25 mm  x 8

QQ Poignée  x 4

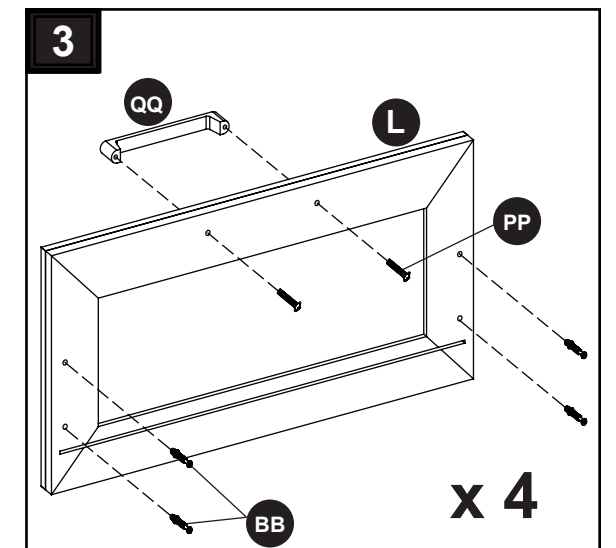



INSTRUCTIONS POUR L'ASSEMBLAGE

4. Fixez la façade du tiroir (L) au tiroir gauche (I), au tiroir droit (J) à l'aide de petits attaches camloc (LL). Emboîtez les couvercles en plastique (II) pour couvrir les petits verrous à came pour une belle apparence.

Répétez les étapes précédentes pour fixer les trois autres tiroirs

Quincaillerie Utilisée

LL	Petite Attache Camloc		x 16
II	Couvercle en Plastique		x 16

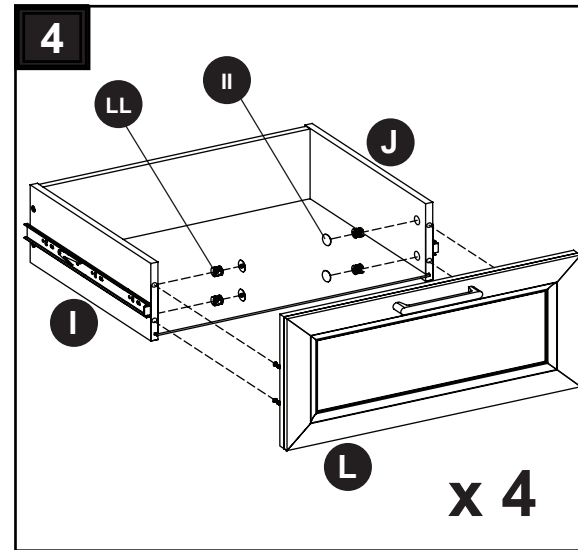

5. Installez les boulons à came (BB) et les goujon de bois (CC) dans les trous pré-perçés sur le panneau latéral gauche (B) et le panneau latéral droit (C) et s'assurer qu'ils sont complètement en place, fixer la glissière arrière (E) et les glissières avant (F) au panneau latéral gauche (B) et au panneau latéral droit (C) à l'aide des attaches camloc (AA) comme indiqué sur la figure.

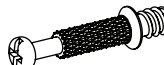
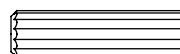

Quincaillerie Utilisée

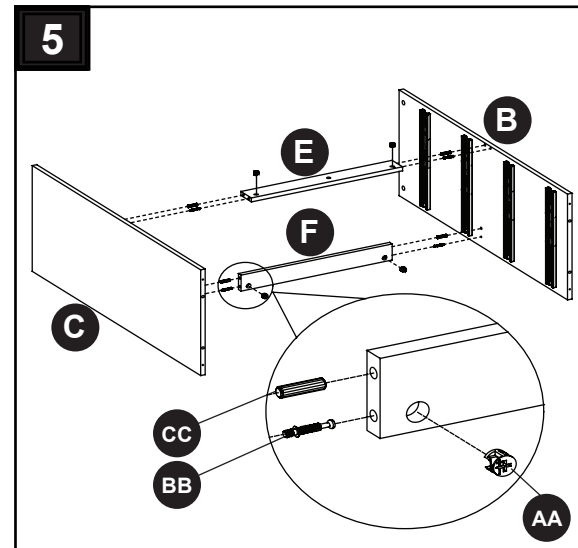
AA	Attache Camloc		x 4
BB	Boulon à came		x 4
CC	Goujon de bois		x 4



6. Insérez les boulons à came (BB) et les goujon de bois (CC) dans les trous pré-perçés du panneau supérieur (A), positionnez le panneau supérieur (A) sur le panneau latéral gauche (B) et le panneau latéral droit (C) à l'aide des attaches camloc (AA) comme indiqué sur la figure.

Quincaillerie Utilisée

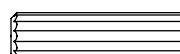
AA	Attache Camloc		x 4
BB	Boulon à came		x 4
CC	Goujon de bois		x 4

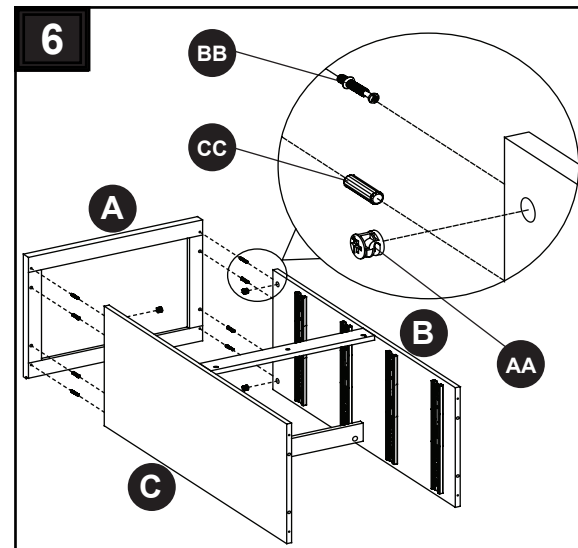

INSTRUCTIONS POUR L'ASSEMBLAGE

7. Insérez les goujon de bois (CC) dans le panneau inférieur (G). Fixez le panneau inférieur (G) au panneau latéral gauche (B) et au panneau latéral droit (C) en le fixant avec des vis M4 x 50 mm (DD).

Quincaillerie Utilisée

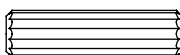
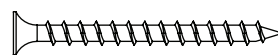
CC	Goujon de bois		x 4
DD	Vis M4 x 50 mm		x 4

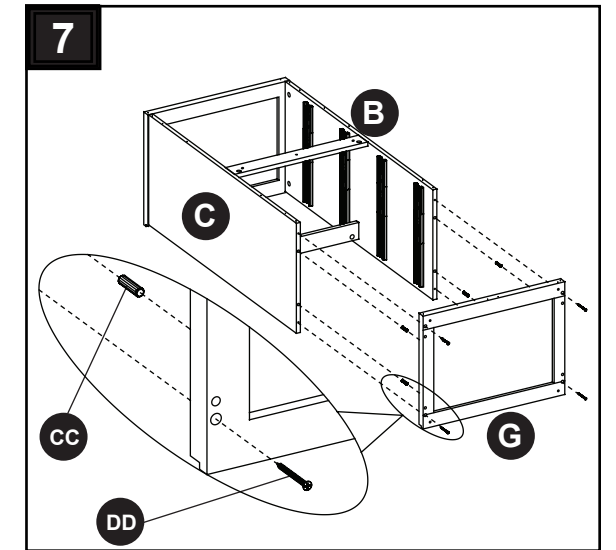

8. Déployez le panneau arrière (D) et posez-le sur les bords arrière du cadre assemblé en vous assurant que les marges le long de tous les bords sont égales. Fixez le panneau arrière en place à l'aide de vis M3, 5 x 15 mm (FF) à travers les trous pré-perçés du panneau arrière.

Quincaillerie Utilisée

FF	Vis M3.5 x 15 mm		x 22
-----------	------------------	---	------

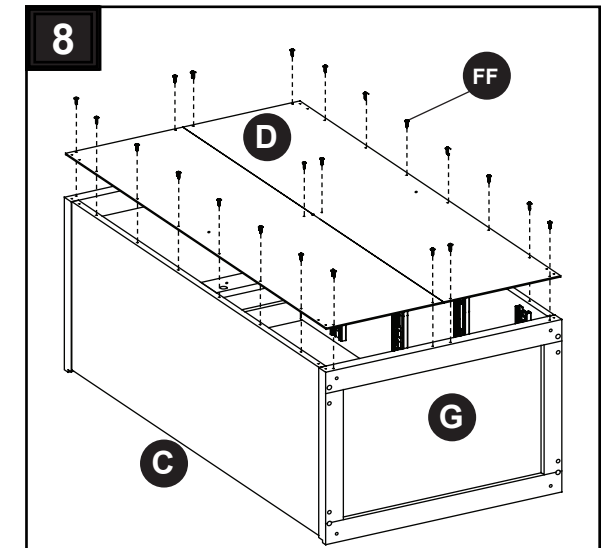

9. Insérez les patin réglable (GG) dans la partie inférieure du panneau inférieur (G).

Quincaillerie Utilisée

GG	Patin réglable		x 4
-----------	----------------	---	-----

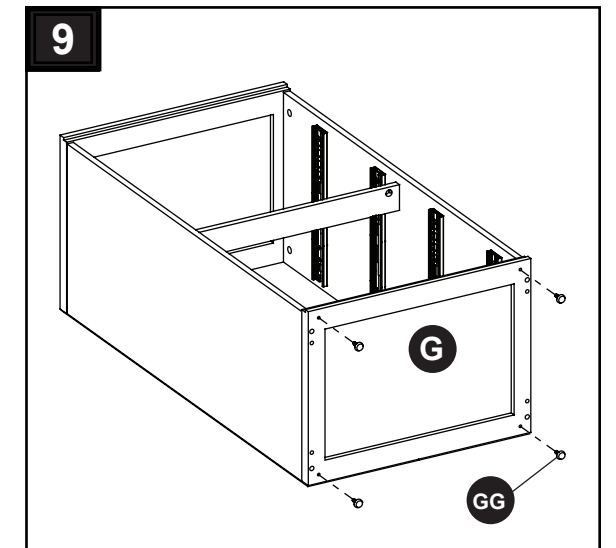

INSTRUCTIONS POUR L'ASSEMBLAGE





10.

- Ajustez le niveleur de sol pour mettre à niveau l'unité contre le mur à l'endroit désiré.
- En utilisant le support arrière (E) comme gabarit, marquez trois trous pour indiquer l'endroit où les trous seront percés.
- Percez trois trous pilotes dans le mur aux endroits marqués précédemment.
- Assurez-vous que les trous percés s'adaptent correctement aux ancrages muraux.
- Enfoncez les chevilles dans les trous et tapez doucement avec un marteau jusqu'à ce qu'elles soient encastrées dans les trous. **REMARQUE** : Si le trou de montage coïncide avec un montant en bois, il n'est pas nécessaire d'utiliser une cheville.
- Alignez le support arrière (E) et les traverses arrière (NN) sur les ancrages pour placoplâtre (MM) et fixez-les avec des vis M5 x 65 mm (OO).
- Serrez fermement les vis à l'aide d'un tournevis Phillips.

Si vous souhaitez que cette unité soit au ras du mur, vous pouvez couper la plinthe du mur, puis la fixer avec une vis M5 x 65 mm (OO) sans traverse arrière (NN).

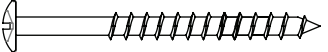
Placez les bouchons en plastique (II) pour recouvrir les serrures à came à des fins esthétiques.

Quincaillerie Utilisée

- OO** Vis M5 x 65 mm  x 3
- II** Couvercle en Plastique  x 4
- MM** Cheville d'ancrage  x 3
- NN** Traverse arrière  x 3

11. Installation de tiroir

- Prolongez les chariots à roulement à billes de l'unité jusqu'au bout (y compris le chariot à roulement à billes).
- Alignez les glissières des tiroirs assemblés avec les rails à glissière et poussez le tiroir avec précaution à l'intérieur jusqu'à ce qu'il s'arrête.

REMARQUE: Si le tiroir n'entre pas en douceur, veuillez le sortir et répéter l'opération. Si vous devez retirer le tiroir, veuillez le tirer à fond, puis poussez simultanément le levier de déblocage en plastique des glissières à billes vers le haut d'un côté et vers le bas de l'autre côté, puis tirez-le complètement.

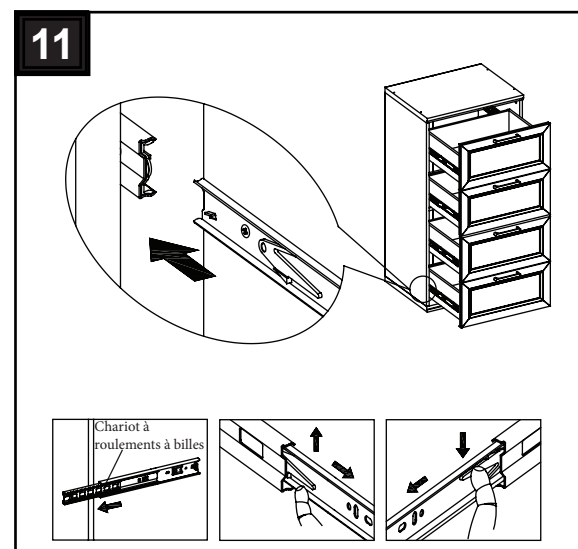
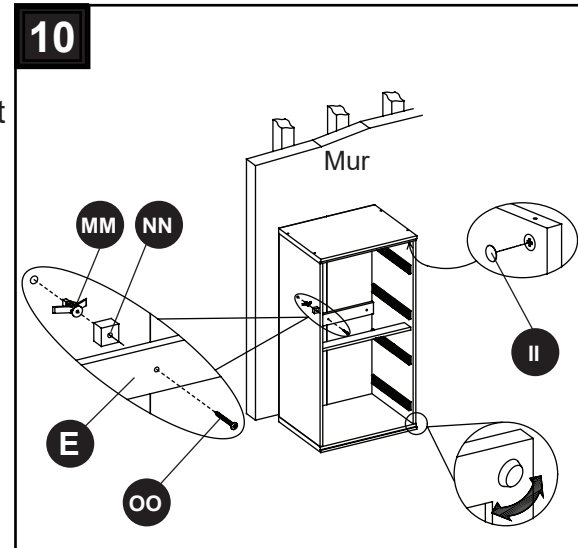

INSTRUCTIONS POUR L'ASSEMBLAGE

12 Cet meuble a été conçu avec une fonctionnalité qui permet d'empiler deux unités. Unités supplémentaires vendues séparément. Insérez les goujon de bois (CC) dans les trous situés sur le dessus de l'unité de base. Placez le bas de la deuxième unité sur les chevilles insérées. Fixez les unités ensemble en attachant les plaques métalliques (EE) aux deux extrémités avec les vis M3,5 x 19 mm (JJ) dans les trous pré-perçés.

Si vous prévoyez d'utiliser cette unité comme buffet (la poser sur une autre unité), veuillez ignorer les étapes 9 et 13

REMARQUE : Retirez les Couvercle (HH) avant d'empiler deux unités ensemble.

Quincaillerie Utilisée

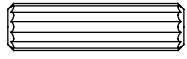
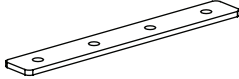
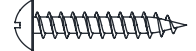
- CC** Goujon de bois  x 4
- EE** Plaque Métallique  x 1
- JJ** Vis M3.5 x 19 mm  x 4

13. Insérez les Couvercle (HH) dans les trous situés sur le panneau supérieur (A).

Quincaillerie Utilisée

- HH** Couvercle  x 4

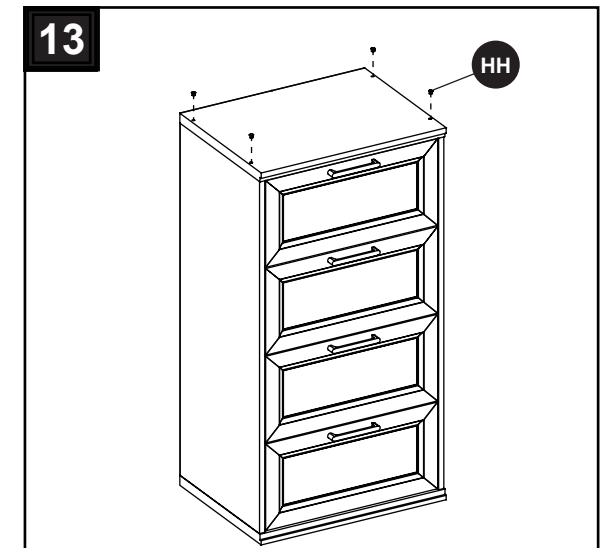
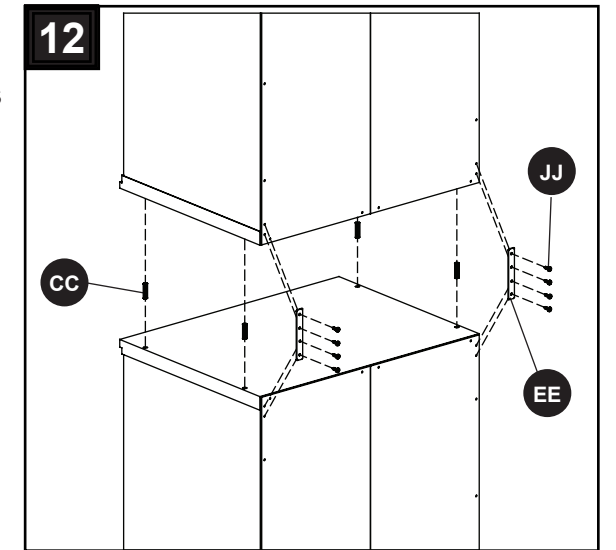

SOIN ET ENTRETIEN

- Vérifiez périodiquement si les composants sont bien positionnés, en bon état et fermement montés.
- Utilisez un linge doux et propre qui n'égratignera pas la surface lorsque vous époussetterez le meuble.
- N'utilisez jamais d'eau pour nettoyer le meuble puisque vous risqueriez d'endommager le fini.
- Nettoyez le meuble à l'aide d'un linge humide et d'un nettoyant doux. Essuyez le meuble à l'aide d'un linge propre.
- Si le meuble est taché ou endommagé de quelque façon durant son utilisation, il est recommandé d'appeler un professionnel pour le faire réparer.
- Conservez le meuble à l'abri du soleil pour éviter d'endommager le fini.
- Il est préférable que le meuble soit gardé dans un endroit à température contrôlée. Les variations d'humidité et de température importantes peuvent décolorer, déformer, contracter et même fendre le bois.

GARANTIE LIMITÉE À VIE

Ce produit est garanti à l'acheteur original. En cas de défaut de fabrication ou des matériaux, le fabricant réparera ou remplacera cet article, à sa discrétion, sans frais. La garantie est nulle si le produit a été mal assemblé, utilisé inadéquatement, abusé par la surcharge, modifié de quelque manière que ce soit ou endommagé suite à un accident. La présente garantie n'est pas transférable et ne couvre pas l'écaillage, les éraflures, la rouille, l'enfoncement ni les autres dommages aux surfaces du produit. La responsabilité du fabricant se limite à réparer ou remplacer ce produit. Le fabricant n'est pas responsable des dommages indirects ou accessoires ou de tout autre dommage ou perte résultant d'un bris du produit.

La présente garantie remplace toute autre garantie expresse. Certaines régions ne permettent pas l'exclusion ni la limite des dommages indirects ou accessoires et dans de tels cas, la limite précédente pourrait ne pas s'appliquer. La présente garantie vous donne des recours légaux particuliers et vous pourriez bénéficier d'autres droits qui varient d'une région à l'autre.

LISTE DES PIÈCES DE RECHANGE

Pour obtenir des pièces de rechange, communiquez avec notre service à la clientèle au 1-877-888-8225, entre 8 h et 20 h (HNE), du lundi au dimanche.

PIÈCE	DESCRIPTION	PIÈCE #
A	Panneau supérieur	00LWSCDS-A
B	Panneau latéral gauche	00LWSCDS-B
C	Panneau latéral droit	00LWSCDS-C
D	Panneau arrière	00LWSCDS-D
E	Civière arrière	00LWSCDS-E
F	Civière avant	00LWSCDS-F
G	Panneau inférieur	00LWSCDS-G
H	Tiroir arrière	00LWSCDS-H
I	Tiroir gauche	00LWSCDS-I
J	Tiroir droit	00LWSCDS-J
K	Panneau inférieur du tiroir	00LWSCDS-K
L	Front du tiroir	00LWSCDS-L

LISTE DES PIÈCES DE RECHANGE

Pour obtenir des pièces de rechange, communiquez avec notre service à la clientèle au 1-877-888-8225, entre 8 h et 20 h (HNE), du lundi au dimanche.

PIÈCE	DESCRIPTION	PIÈCE #
AA	Attache Camloc	00LWSCDS-AA
BB	Boulon à came	00LWSCDS-BB
CC	Goujon de bois	00LWSCDS-CC
DD	Vis M4 x 50 mm	00LWSCDS-DD
EE	Plaque Métallique	00LWSCDS-EE
FF	Vis M3.5 x 15 mm	00LWSCDS-FF
GG	Patin réglable	00LWSCDS-GG
HH	Couvercle	00LWSCDS-HH
II	Couvercle en Plastique	00LWSCDS-II
JJ	Vis M3.5 x 19 mm	00LWSCDS-JJ
KK	Vis M4 x 38 mm	00LWSCDS-KK
LL	Petite Attache Camloc	00LWSCDS-LL
MM	Cheville d'ancrage	00LWSCDS-MM
NN	Traverse arrière	00LWSCDS-NN
OO	Vis M5 x 65 mm	00LWSCDS-OO
PP	Boulon 5/32" x 25 mm	00LWSCDS-PP
QQ	Poignée	00LWSCDS-QQ
RR	Glissières de tiroir	00LWSCDS-RR
CH	Quincaillerie complète	00LWSCDS-CH

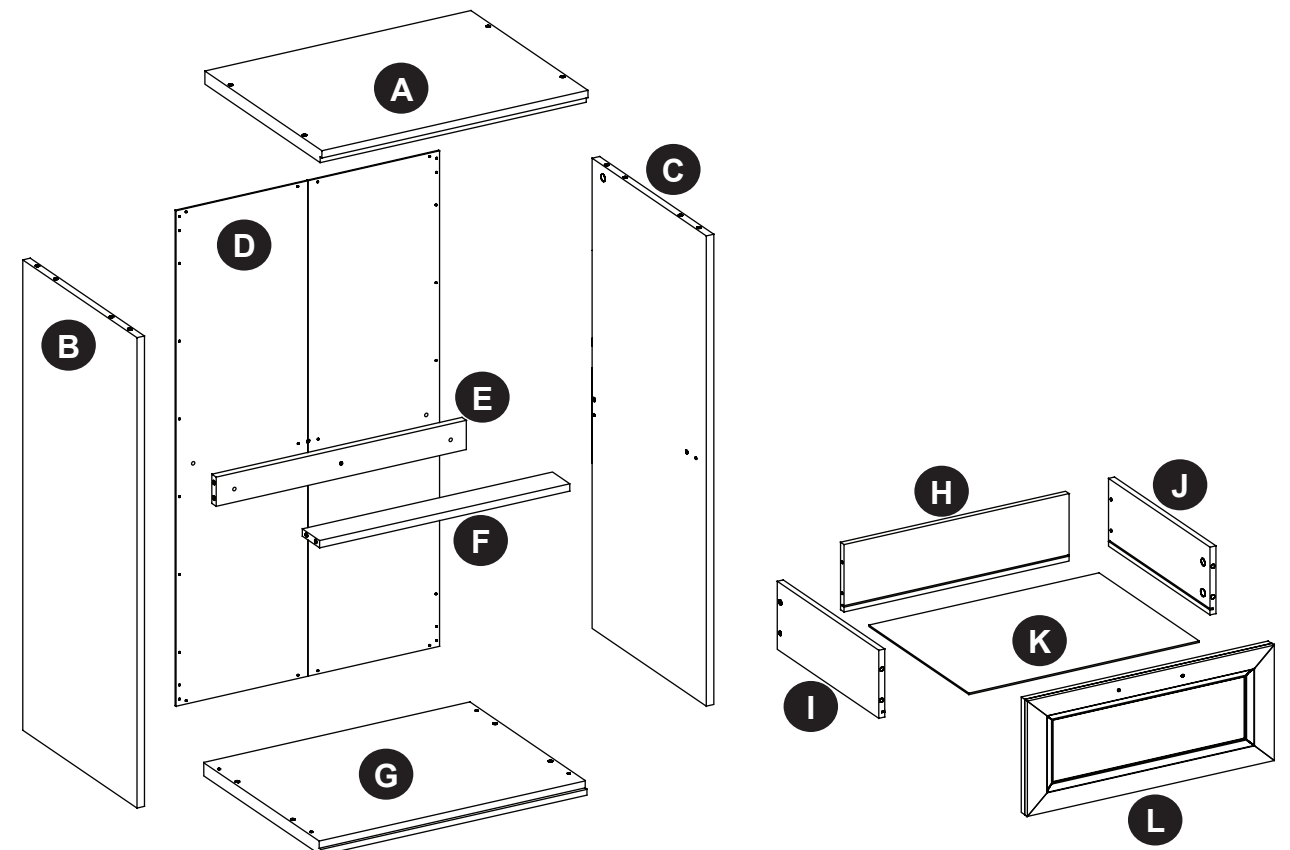

LISTE DES PIÈCES DE RECHANGE

Pour obtenir des pièces de rechange, communiquez avec notre service à la clientèle au 1-877-888-8225, entre 8 h et 20 h (HNE), du lundi au dimanche.

AA

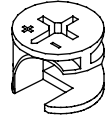

BB

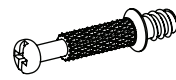

CC

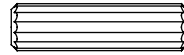

DD

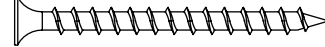

EE

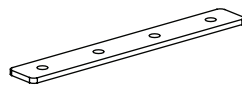

FF



GG

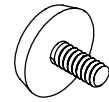

HH



II



JJ



KK

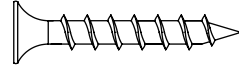

LL



MM

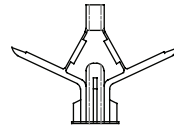

NN

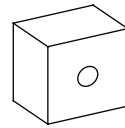

OO

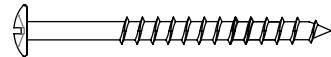

PP



QQ

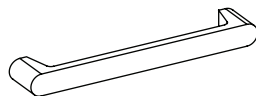

RR

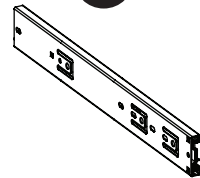

STYLE SELECTIONS es una marca o marca registrada de LF, LLC. Todos los derechos reservados.

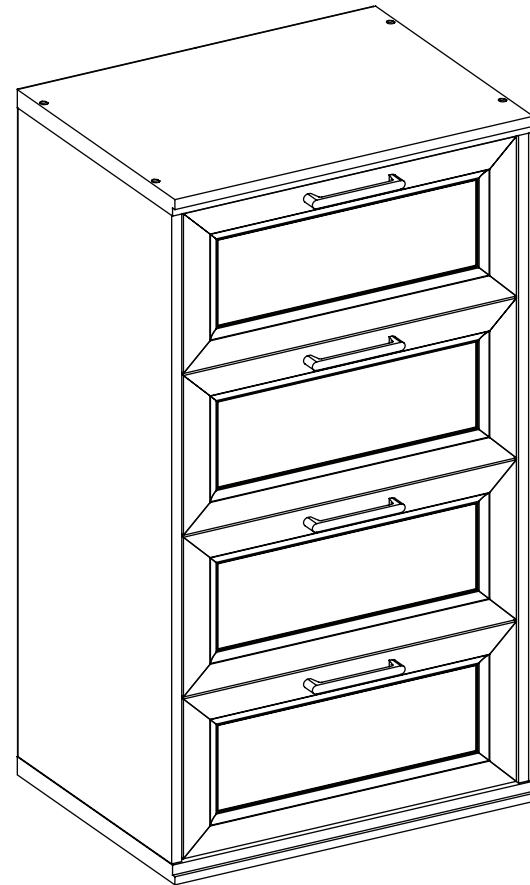

CONTENIDO DEL PAQUETE

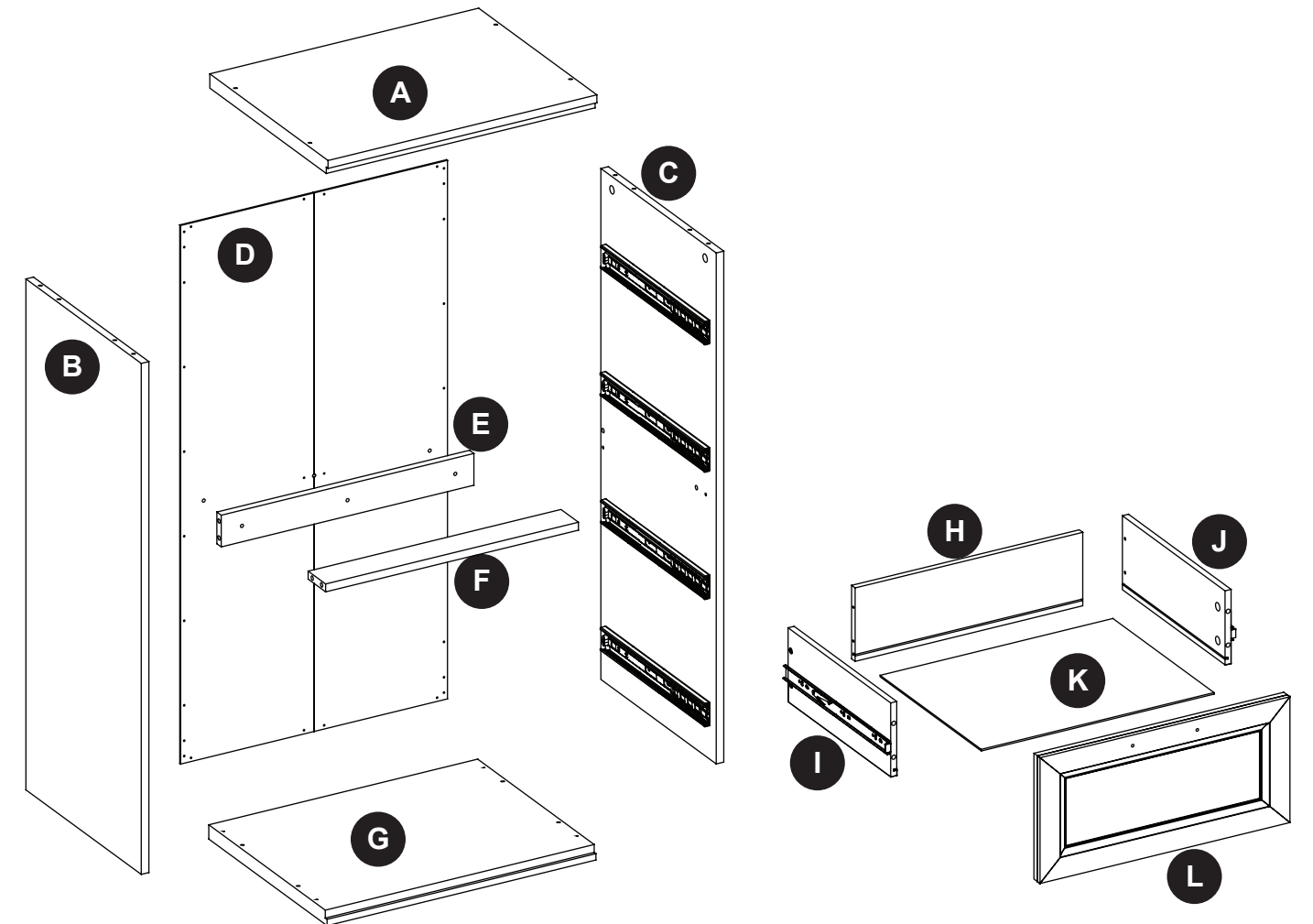

ARTÍCULO #5120854
ALMACENAMIENTO EN GAVETAS
MODELO #LWSCDS

! ADVERTENCIA

Por favor lea y entienda este manual completamente antes de intentar el ensamblaje, operación, o instalación del producto.

LA UNIDAD DEBE FIJARSE PERMANENTEMENTE A LA PARED CON LOS ACCESORIOS PROPORCIONADOS; ESTA UNIDAD DE ALMACENAMIENTO NO ESTÁ DISEÑADA NI DESTINADA PARA USO INDEPENDIENTE.

ADJUNTE SU RECIBO AQUÍ

Número de serie _____ Fecha de compra _____

PIEZA	DESCRIPCIÓN	CANTIDAD
A	Panel superior	1
B	Panel lateral izquierdo	1
C	Panel lateral derecho	1
D	Respaldo	1
E	Soporte posterior	1
F	Soporte frontal	1

PIEZA	DESCRIPCIÓN	CANTIDAD
G	Panel inferior	1
H	Parte trasera de cajón	4
I	Parte izquierda de cajón izquierdo	4
J	Parte derecha de cajón	4
K	Panel inferior de la gaveta	4
L	Frente del cajón	4



¿Preguntas? Llamar a servicio al cliente al 1-877-888-8225, 8 a.m. - 8 p.m., EST, Lunes - Domingo.

FUNCIONAMIENTO DEL SISTEMA DE CERROJO DE LEVA

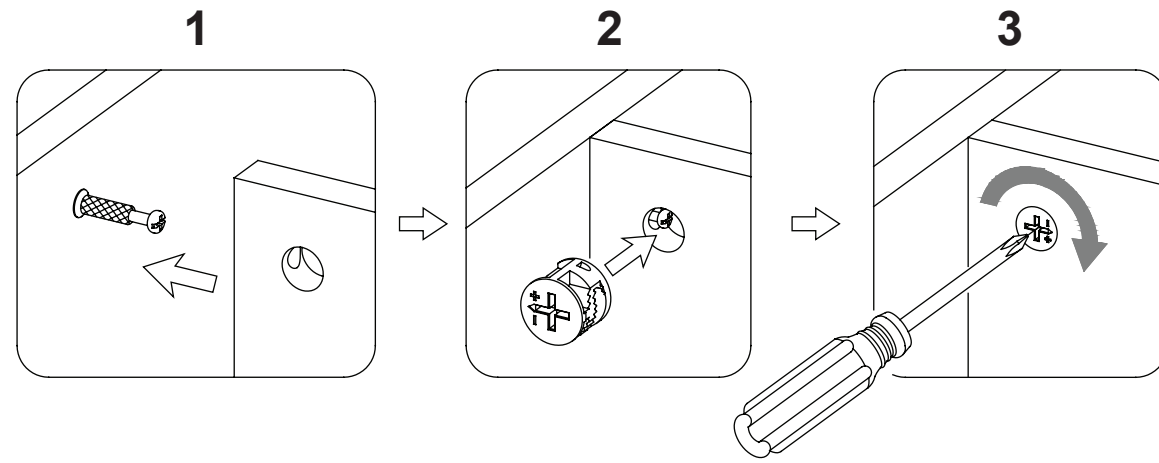





1. Fijar los pernos de fijación en los orificios pequeños. Conectar ambos paneles, cerciorándose que los pernos de fijación entren bien y que estos queden en los orificios al final del panel con tuercas de fijación.
2. Inserte las tuercas de fijación en los orificios grandes del panel. Hacer que la flecha en la tuerca este apuntando hacia la entrada del perno de fijación.
3. Una vez que el perno esté conectado dentro, tome un destornillador de cruz y apriete la tuerca en dirección de las manecillas del reloj.

CONTENIDOS DE FERRETERÍA (no se muestran en tamaño real)

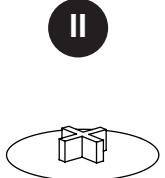
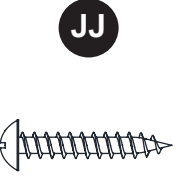
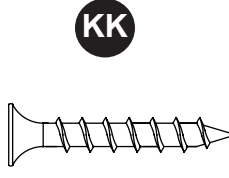
 AA Cerrojo de leva Cant. 8	 BB Perno de fijación Cant. 24	 CC Espiga de madera Cant. 16	 DD Tornillo M4 x 50 mm Cant. 4
 EE Placa metálica Cant. 1	 FF Tornillo M3.5 x 15 mm Cant. 22	 GG Nivelador de suelo Cant. 4	 HH Tapa Cant. 4

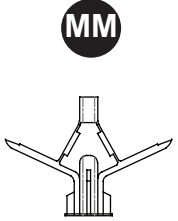
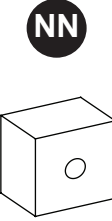
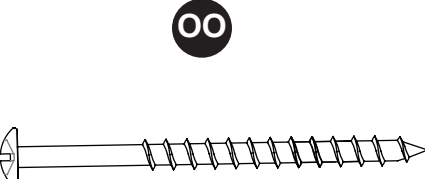
CONTENIDOS DE FERRETERÍA (no se muestran en tamaño real)

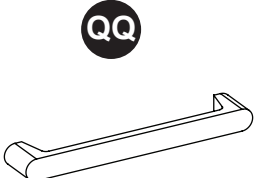
 II Cubierta plástica Cant. 20	 JJ Tornillo M3.5 x 19 mm Cant. 4	 KK Tornillo M4 x 38 mm Cant. 16	 LL Pequeña Cerrojo de leva Cant. 16
 MM Ancla de expansión de pared Cant. 3	 NN Soporte posterior Cant. 3	 OO Tornillo M5 x 65 mm Cant. 3	 PP Perno de 5/32" x 25 mm Cant. 8
 QQ Manija Cant. 4			

! INFORMACIÓN DE SEGURIDAD

Por favor lea y entienda este manual completamente antes de intentar el ensamblaje, operación, o instalación del producto.

1. No permita a los niños escalar o jugar en o alrededor de este producto.
2. Use esta sola unidad para su propósito previsto. No usar las repisas como escalones.
3. Para evitar daños, ensamblar el producto en una superficie fuerte, nivelada y protegida.
4. Asegurar de que los pernos y tuercas estén apretados antes de usar la unidad.
5. Revisar que los pernos y tuercas estén apretados periódicamente y apretar como sea necesario.
6. **La unidad debe fijarse permanentemente a la pared con los accesorios proporcionados; Esta unidad de almacenamiento no está diseñada ni destinada para uso independiente.**

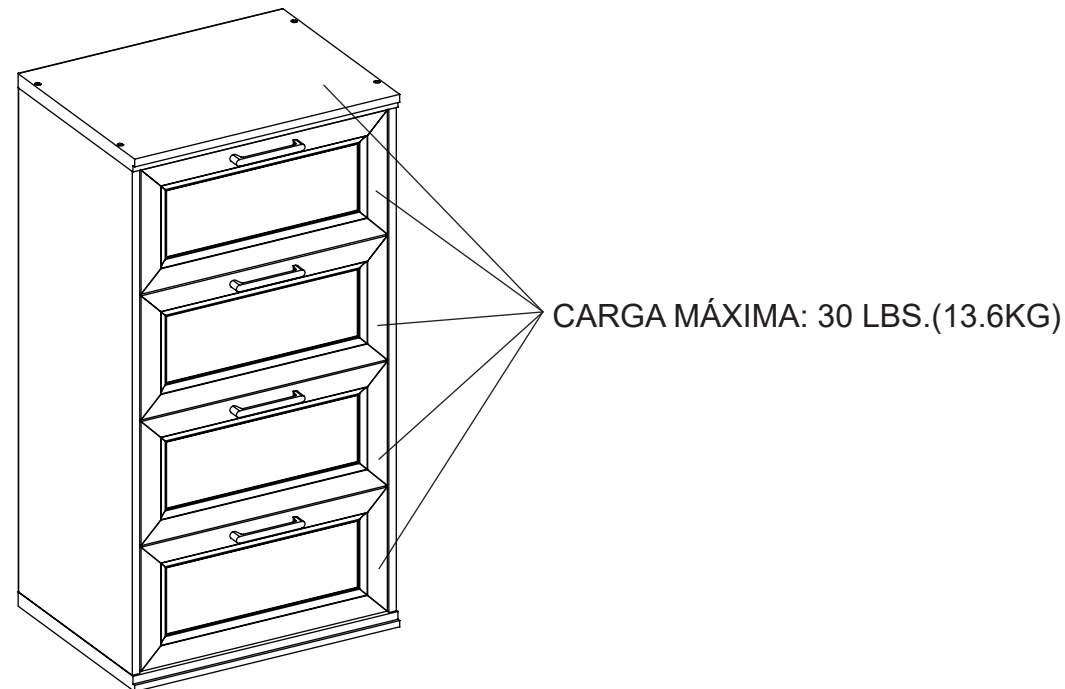

! ADVERTENCIA

EL OBJETO ESTÁ DISEÑADO PARA USARSE SOLO CON PESOS MÁXIMOS INDICADOS. LA SOBRECARGA DEL OBJETO DE ALMACENAMIENTO CON PRODUCTOS MÁS PESADOS QUE EL PESO MÁXIMO PUEDE PROVOCAR LESIONES. DISTRIBUYA CUALQUIER PESO EN OBJETOS DE MANERA UNIFORME.

PREPARACIÓN

Antes de empezar el ensamblaje del producto, asegure de que estén presentes todas las partes. Compare las partes con la lista de contenido del paquete y la lista de ferretería. Si alguna parte está perdida o dañada, no intente ensamblar el producto.

Tiempo de ensamblaje estimado: 50 minutos.

Herramientas requeridas para el ensamblaje (no incluidas): Martillo de goma, destornillador phillips.

INSTRUCCIONES DE ENSAMBLAJE

1. Fije el cajón izquierdo (I) y el cajón derecho (J) a la parte trasera del cajón (H), apriete con tornillos M4 x 38 mm (KK).

Ferretería Usada

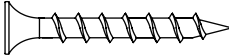
KK Tornillo M4 x 38 mm  x 16

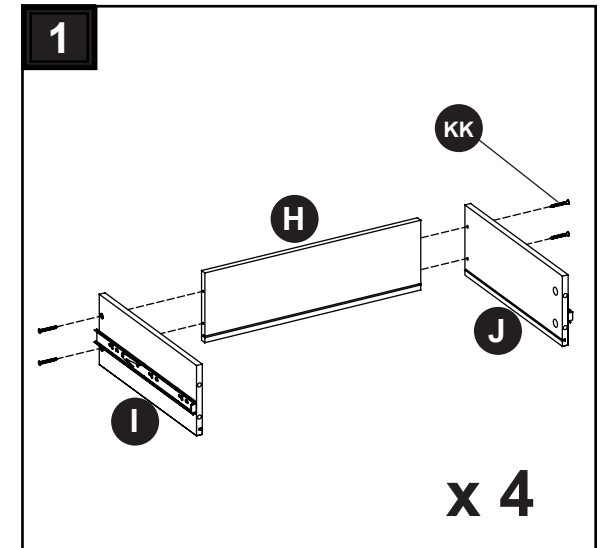

2. Introduzca el fondo del cajón (K) en la parte izquierda (I), la parte derecha (J) y el fondo del cajón (H).

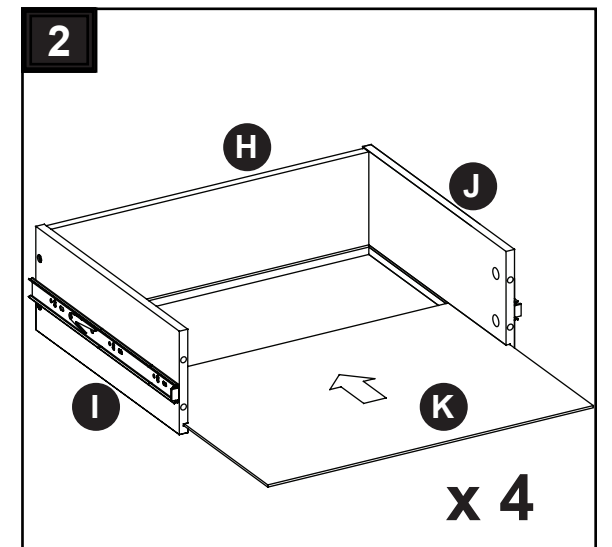

3. Inserte los pernos de fijación (BB) en el frente del cajón (L). Fije una manija (QQ) en la parte delantera del cajón (L) por medio de los pernos de 5/32" x 25 mm (PP) suministrados.

Ferretería Usada

BB Perno de fijación  x 16

PP Perno de 5/32" x 25 mm  x 8

QQ Manija  x 4

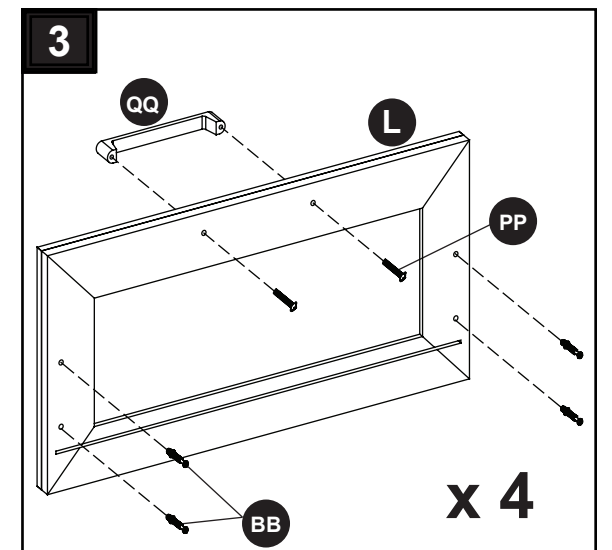



INSTRUCCIONES DE ENSAMBLAJE

4. Ajuste el frente del cajón (L) al cajón izquierdo (I), al cajón derecho (J) con ayuda de los cerrojo de leva pequeños (LL).

Coloque las cubierta plástico (II) en los cierres de leva pequeños para conseguir un aspecto agradable.

Repita los pasos anteriores para fijar los otros tres cajones.

Ferretería Usada

LL	Pequeña Cerrojo de leva		x 16
II	Cubierta plástica		x 16

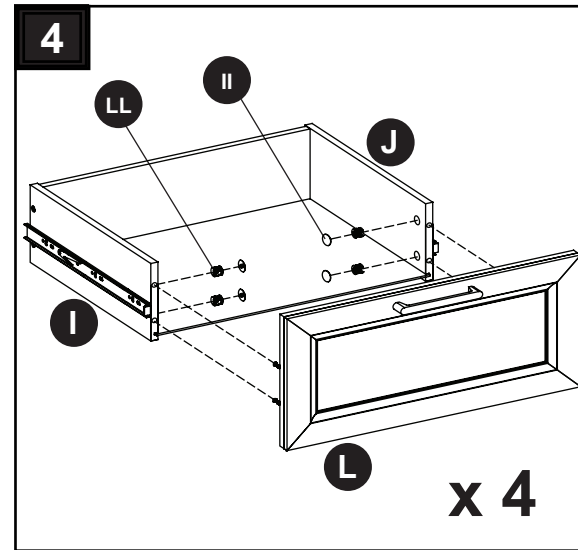

5. Instale los pernos de fijación (BB) y los espiga de madera (CC) en los orificios previamente perforados en el panel lateral izquierdo (B) y el panel lateral derecho (C) y asegúrese de que estén completamente ajustados, fije el tensor trasero (E) y los delanteros (F) al panel lateral izquierdo (B) y al panel lateral derecho (C) con los cerrojo de leva (AA) como se muestra en la figura.

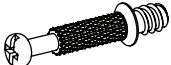
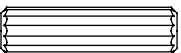

Ferretería Usada

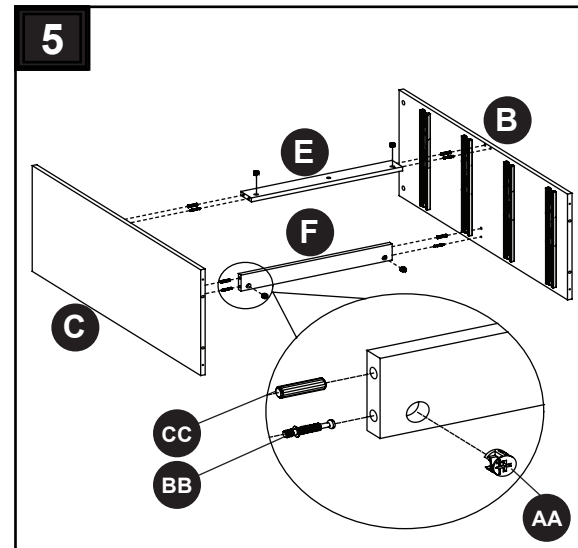
AA	Cerrojo de leva		x 4
BB	Perno de fijación		x 4
CC	Espiga de madera		x 4



6. Inserte los pernos de fijación (BB) y los espiga de madera (CC) en los orificios previamente perforados en el panel superior (A); coloque el panel superior (A) en el panel lateral izquierdo (B) y el panel lateral derecho (C) con los cerrojo de leva (AA) como se muestra en la figura.

Ferretería Usada

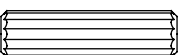
AA	Cerrojo de leva		x 4
BB	Perno de fijación		x 4
CC	Espiga de madera		x 4

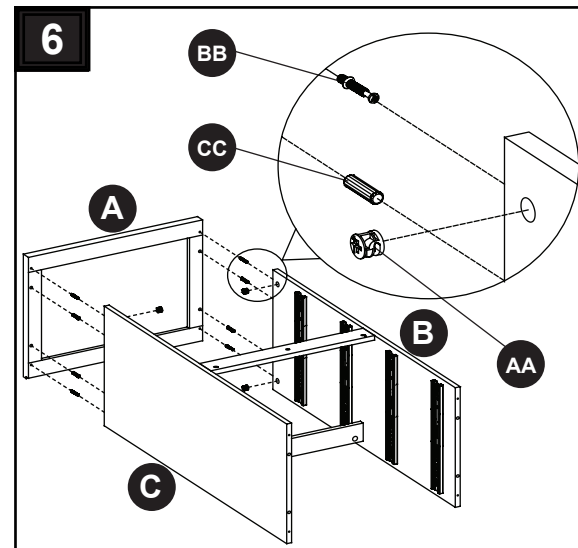

INSTRUCCIONES DE ENSAMBLAJE

7. Inserte los espiga de madera (CC) en el panel inferior (G). Fije el panel inferior (G) al panel lateral izquierdo (B) y al panel lateral derecho (C) con tornillos M4 x 50 mm (DD).

Ferretería Usada

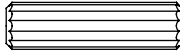
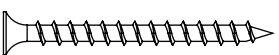
CC	Espiga de madera		x 4
DD	Tornillo M4 x 50 mm		x 4

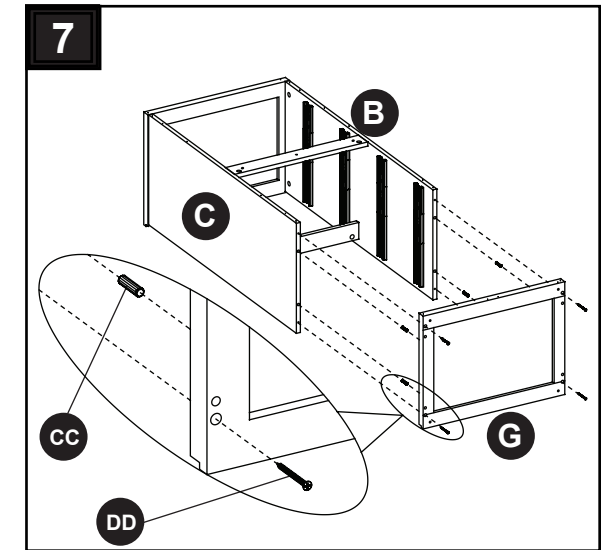

8. Despliegue el panel trasero (D) y colóquelo sobre los bordes traseros del marco ensamblado asegurándose de que los márgenes a lo largo de todos los bordes sean iguales. Fije el panel trasero en su lugar con tornillos M3,5 x 15 mm (FF) a través de sus orificios previamente perforados.

Ferretería Usada

FF	Tornillo M3.5 x 15 mm		x 22
-----------	-----------------------	---	------

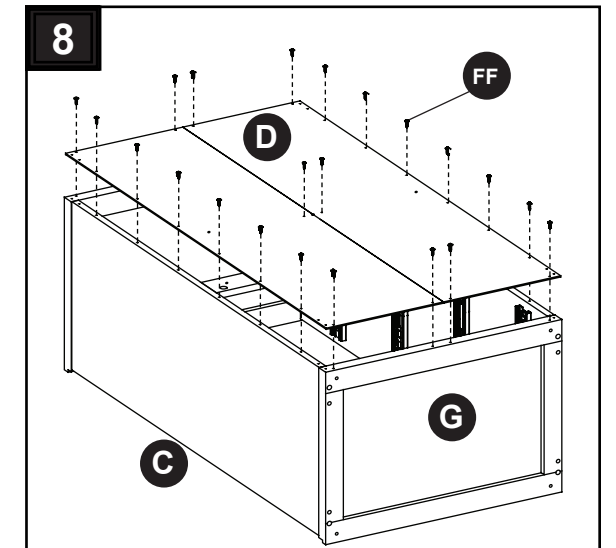

9. Inserte los niveladores de suelo (GG) en la parte inferior del panel trasero (G).

Ferretería Usada

GG	Nivelador de suelo		x 4
-----------	--------------------	---	-----

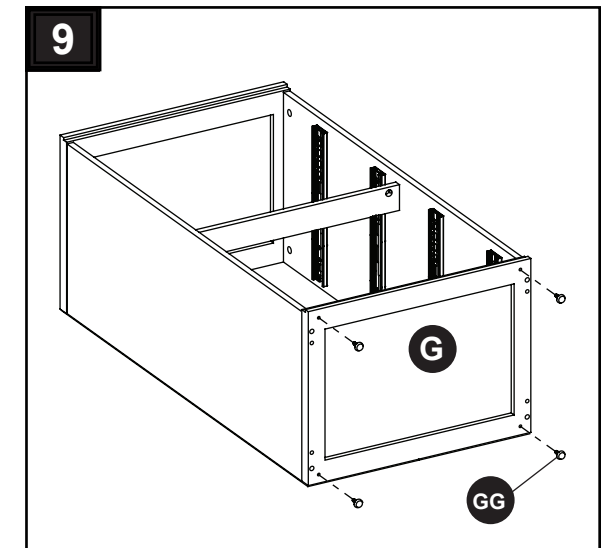

INSTRUCCIONES DE ENSAMBLAJE





10.

- a. Ajuste los niveladores de piso para nivelar la unidad contra la pared donde se desee.
- b. Usando el bastidor trasero (E) como soporte, marque tres agujeros para indicar dónde se perforarán los agujeros.
- c. Taladre tres agujeros piloto en la pared donde antes se ha marcado.
- d. Asegúrese de que los orificios perforados encajen en los anclajes de pared propiamente.
- e. Presione los anclajes en los orificios y golpee suavemente con un martillo hasta que quede al ras en los agujeros. **TENGA EN CUENTA:** Si el orificio de montaje coincide con un montante de madera, no hay necesidad de un anclaje a la pared.
- f. Alinee la camilla de espalda (E) y las cruces de espalda (NN) sobre los anclajes para paneles de yeso (MM) y asegúrelos con M5 x 65 mm tornillo (OO).
- g. Apriete los tornillos de forma segura con un destornillador Phillips.

Si desea que el objeto quede al ras de la pared, puede cortar el zócalo de la pared, y luego asegúrelo con M5 x 65 mm tornillo (OO) sin cruzador trasero (NN).

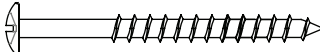
Ponga cubiertas de plástico (II) para cubrir las cerraduras de leva por.

Ferretería Usada

OO	Tornillo M5 x 65 mm		x 3
II	Cubierta plástica		x 4
MM	Ancla de expansión de pared		x 3
NN	Soporte posterior		x 3

11. Instalación del cajón

- 1a. Extender los carriles de la corredera de baleros en los paneles todo el camino hacia enfrente (incluyendo el carrito de baleros).
- 1b. Alinear los complementos de corredera en los cajones ensamblados con los carriles de corredera y empujar el cajón hacia adentro hasta que tope.

NOTA: Si el cajón no se mueve suavemente, por favor saque y repita el paso. Si necesita sacar el cajón, por favor jale el cajón todo el camino, y empuje simultáneamente las palancas de liberación de plástico de las correderas de baleros hacia arriba en una y hacia abajo en la otra, después jalé el cajón completamente afuera.

35

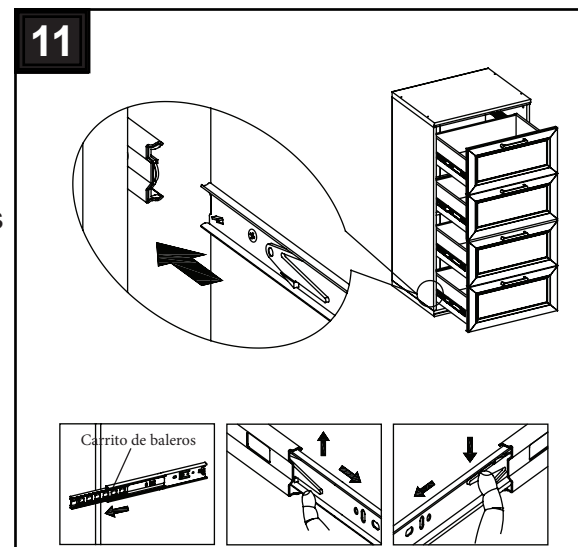
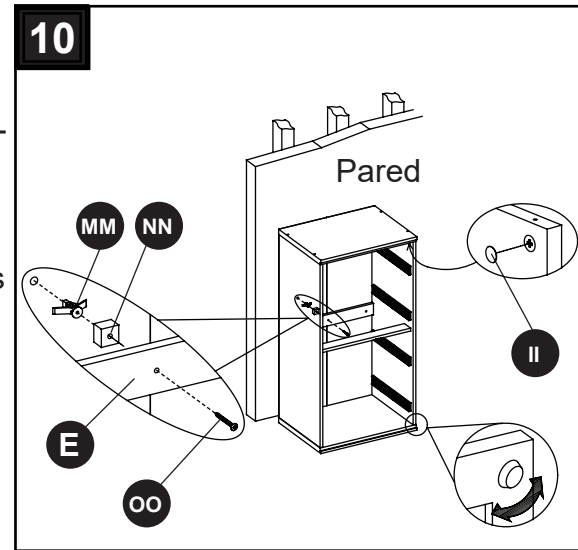



INSTRUCCIONES DE ENSAMBLAJE

12. Este armario fue diseñado para permitir que se apilen dos unidades. Las unidades adicionales se venden por separado. Introduzca los espiga de madera (CC) en los orificios de la parte superior de la unidad base. Coloque la parte inferior de la segunda unidad sobre los tacos colocados. Fije las unidades entre sí con las placas metálicas (EE) en ambos extremos y con los tornillos M3,5 x 19 mm (JJ) dentro de los orificios previamente perforados. Si piensa utilizar esta unidad como alacena (sobre otra), omita los pasos 9 y 13.

NOTA: Retire las tapas (HH) antes de apilar dos unidades.

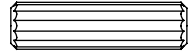
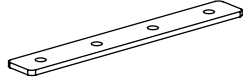
Ferretería Usada

CC	Espiga de madera		x 4
EE	Placa metálica		x 1
JJ	Tornillo M3.5 x 19 mm		x 4

13. Inserte las tapas (HH) en los agujeros de la parte superior del panel superior (A).

Ferretería Usada

HH	Tapa		x 4
-----------	------	---	-----

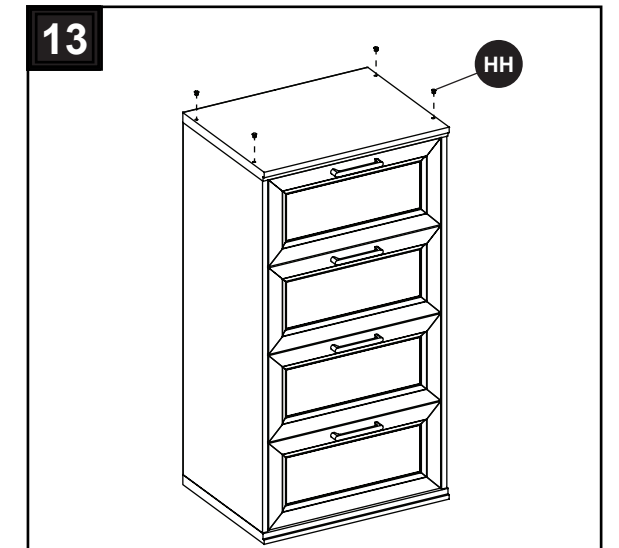
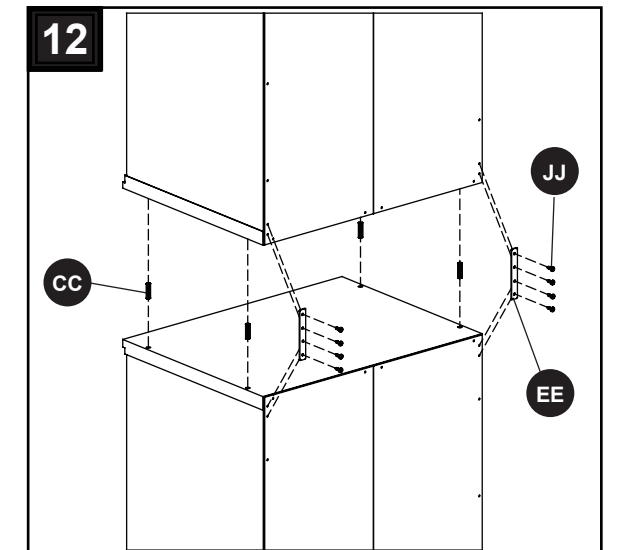

36

MANTENIMIENTO Y CUIDADOS

- Checar periódicamente para asegurar de que todos los componentes están posicionados, libres de daños, y conectados.
- Use una toalla suave y limpia que no rayara la superficie al limpiar el polvo.
- Nunca use agua para limpiar la unidad, ya que le puede dañar el acabado.
- Limpiar usando una tela húmeda y un limpiador ligero. Secar con una toalla limpia.
- En caso que su unidad sea manchada durante el uso le recomendamos hablar a un profesional para que le ayude.
- Es recomendable mantener la unidad lejos del sol directo ya que puede dañar el acabado.
- Es mejor mantener la unidad en un área de clima controlado. Temperatura extrema y cambios de humedad pueden causar cambios como partes pandas, molduras que se contraigan o que la madera se raje.

GARANTÍA LIMITADA DE POR VIDA

La garantía de este producto es válida para el comprador original. Si esta unidad presenta alguna falla debido a defectos en los materiales o la mano de obra, el fabricante reemplazará o reparará este artículo sin cargos y a su discreción. La garantía se anula si el producto no se ensambló correctamente y debido al mal uso, abuso por sobrecarga, modificación de cualquier tipo o daños producidos por un accidente. Esta garantía no es transferible y no cubre el desportillado, desprendimiento, rayones, oxidación, abolladuras u otros daños en la superficie de este producto. La responsabilidad del fabricante se limita a la reparación o el reemplazo de este producto. El fabricante no se hará responsable por daños accidentales o resultantes u otros daños o pérdidas causadas por fallas del producto.

Esta garantía reemplaza a todas las demás garantías explícitas. Algunos estados no permiten la exclusión o limitación de los daños accidentales o resultantes, de modo que las limitaciones anteriores pueden no aplicarse en su caso. Esta garantía le otorga derechos legales específicos, y podría tener otros derechos, que varían según el estado.

LISTA DE PARTE REEMPLAZABLES

Para reemplazar partes, llame a nuestro departamento de servicio al cliente al 1-877-888-8225, 8 a.m. - 8 p.m., Hora estándar del Este, Lunes – Domingo.

PIEZA	DESCRIPCIÓN	PIEZA #
A	Panel superior	00LWSCDS-A
B	Panel lateral izquierdo	00LWSCDS-B
C	Panel lateral derecho	00LWSCDS-C
D	Respaldo	00LWSCDS-D
E	Soporte posterior	00LWSCDS-E
F	Soporte frontal	00LWSCDS-F
G	Panel inferior	00LWSCDS-G
H	Parte trasera de cajón	00LWSCDS-H
I	Parte izquierda de cajón izquierdo	00LWSCDS-I
J	Parte derecha de cajón	00LWSCDS-J
K	Panel inferior de la gaveta	00LWSCDS-K
L	Frente del cajón	00LWSCDS-L

LISTA DE PARTE REEMPLAZABLES

Para reemplazar partes, llame a nuestro departamento de servicio al cliente al 1-877-888-8225, 8 a.m. - 8 p.m., Hora estándar del Este, Lunes – Domingo.

PIEZA	DESCRIPCIÓN	PIEZA #
AA	Cerrojo de leva	00LWSCDS-AA
BB	Perno de fijación	00LWSCDS-BB
CC	Espiga de madera	00LWSCDS-CC
DD	Tornillo M4 x 50 mm	00LWSCDS-DD
EE	Placa metálica	00LWSCDS-EE
FF	Tornillo M3.5 x 15 mm	00LWSCDS-FF
GG	Nivelador de suelo	00LWSCDS-GG
HH	Tapa	00LWSCDS-HH
II	Cubierta plástica	00LWSCDS-II
JJ	Tornillo M3.5 x 19 mm	00LWSCDS-JJ
KK	Tornillo M4 x 38 mm	00LWSCDS-KK
LL	Pequeña Cerrojo de leva	00LWSCDS-LL
MM	Ancla de expansión de pared	00LWSCDS-MM
NN	Soporte posterior	00LWSCDS-NN
OO	Tornillo M5 x 65 mm	00LWSCDS-OO
PP	Perno de 5/32" x 25 mm	00LWSCDS-PP
QQ	Manija	00LWSCDS-QQ
RR	Correderas para cajón	00LWSCDS-RR
CH	Material de ferretería completo	00LWSCDS-CH

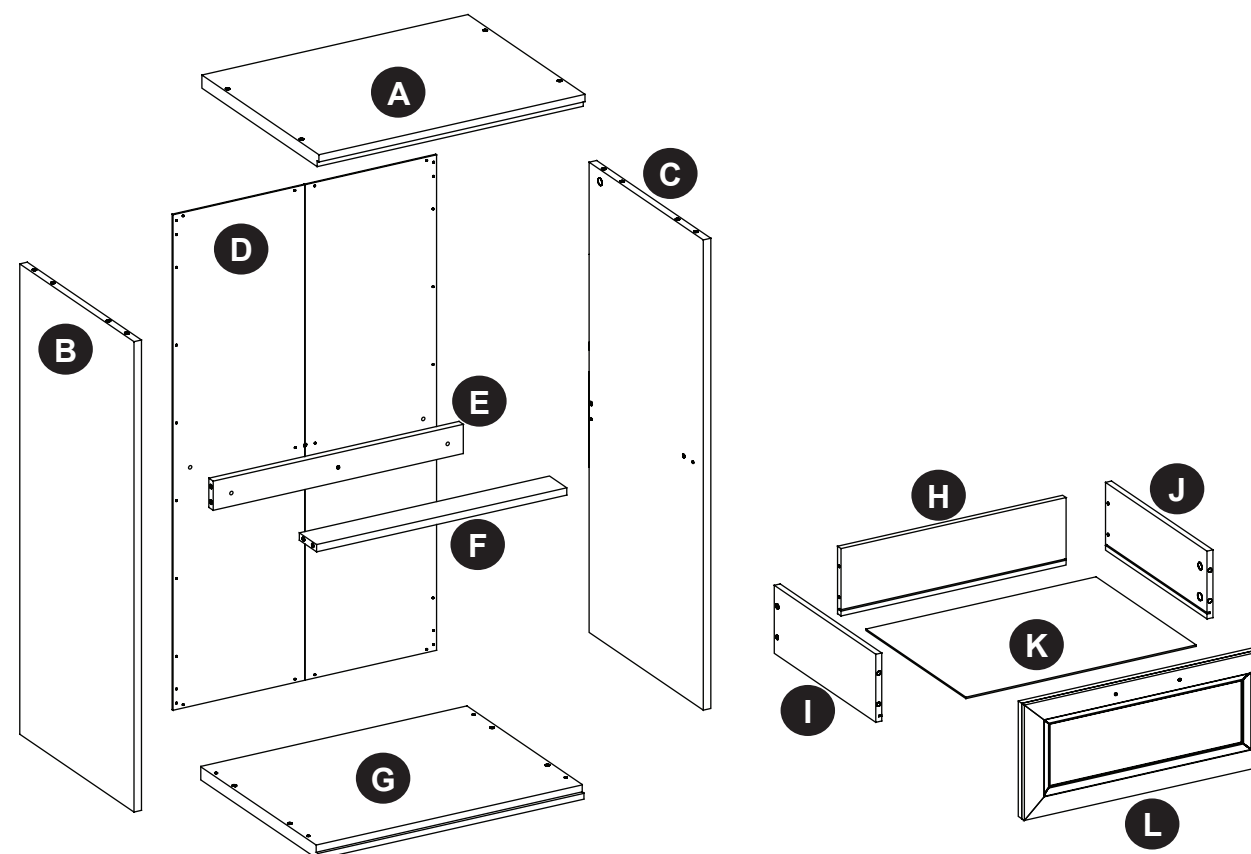

LISTA DE PARTE REEMPLAZABLES

Para reemplazar partes, llame a nuestro departamento de servicio al cliente al 1-877-888-8225,
8 a.m. - 8 p.m., Hora estándar del Este, Lunes – Domingo.

AA

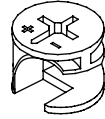

BB

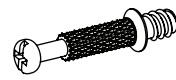

CC



DD

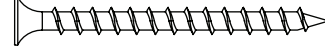

EE

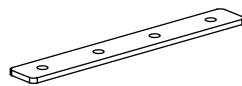

FF



GG

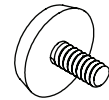

HH



II

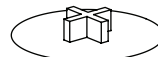

JJ



KK

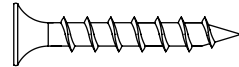

LL



MM

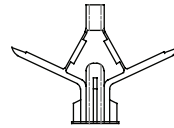

NN

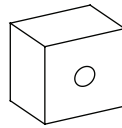

OO

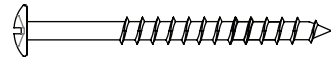

PP



QQ

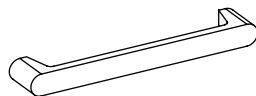

RR

