

Thomasville[®]

LOT NUMBER: _____

DATE PURCHASED: __/__/__

Latimer 48" Desk with Powerstrip

Model # SPLS-LA48D-TV



ADULT ASSEMBLY REQUIRED DUE TO THE PRESENCE OF SMALL PARTS, SHARP POINTS, SHARP EDGES AS RECEIVED

If you have any questions regarding assembly or if parts are missing, DO NOT return this item to the store where it was purchased. Please call our toll-free customer service number and have your instructions and parts list ready to provide the model name, part name or factory number:

1-866-942-5362

Pacific Standard Time: 8:30 a.m. - 4:30 p.m., Monday - Friday

Or visit our web site 24 hours a day, 7 days a week for product assistance at

www.whalenfurniture.com

Or e-mail your request to **parts@whalenfurniture.com**

**THIS INSTRUCTION BOOKLET CONTAINS IMPORTANT SAFETY INFORMATION.
PLEASE READ AND KEEP FOR FUTURE REFERENCE.**

Date 2021-02-24 Rev. 0001-A

Thomasville[™] is a trademark of HHG IPCo, LLC. ©HHG IPCo, LLC. thomasville.com

MAXIMUM RECOMMENDED WEIGHT LOADS

MANUFACTURER: Whalen Furniture Manufacturing
CATALOG: Latimer 48" Desk with Powerstrip
MODEL # SPLS-LA48D-TV

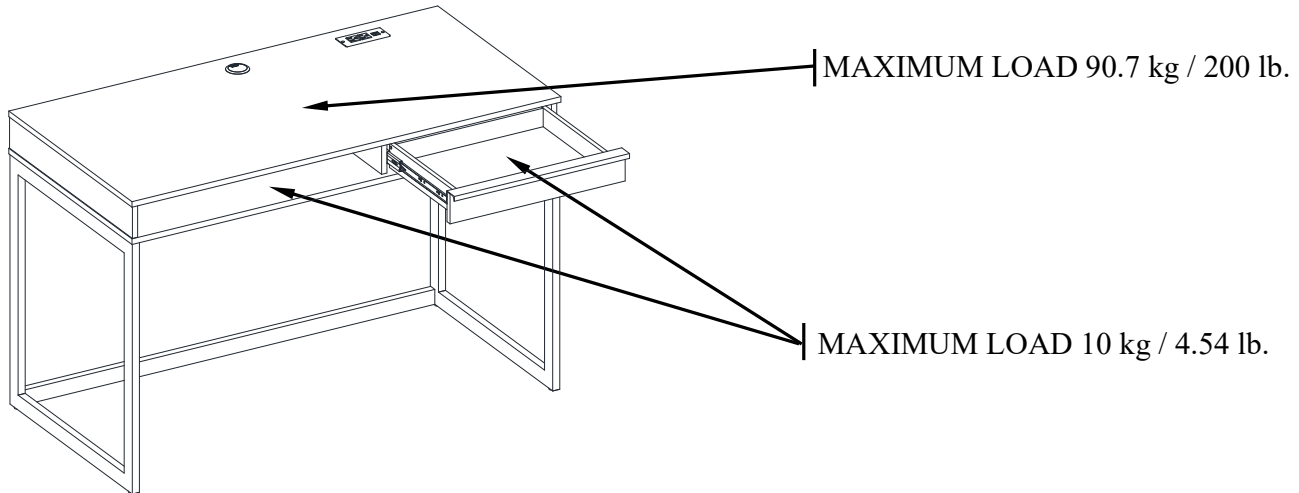

WARNING THIS UNIT IS INTENDED ONLY FOR USE WITHIN THE MAXIMUM WEIGHTS INDICATED. USE WITH LOAD HEAVIER THAN THE MAXIMUM WEIGHTS INDICATED MAY RESULT IN INSTABILITY, CAUSING POSSIBLE INJURY.

SPECIAL NOTE

Please read the instruction sheets completely before assembly. Examine all packaging material before discarding carton. Remove any remaining staples from the carton before discarding. Remove all parts from carton and separate into groups as indicated on part list. Please ensure all parts are included prior to assembly. Use of power tools to complete assembly is not recommended.

FURNITURE TIPPING RESTRAINT

YOUNG CHILDREN MAY BE INJURED BY TIPPING FURNITURE AND YOU MUST USE THIS TIPPING RESTRAINT TO ATTACH THIS UNIT TO THE WALL, TO PREVENT ACCIDENTS AND/OR INJURIES.

THIS HARDWARE MUST BE PROPERLY INSTALLED (FOLLOW ALL DIRECTIONS IN ORDER ON THIS INSTRUCTIONS), TO PROVIDE PROTECTION AGAINST THE UNEXPECTED TIPPING OF FURNITURE DUE TO IMPROPER USE.

THIS PRODUCT IS ONLY A DETERRENT. IT IS NOT A SUBSTITUTE FOR PROPER ADULT SUPERVISION. USE OF TIP-OVER RESTRAINTS MAY ONLY REDUCE, BUT NOT ELIMINATE, THE RISK OF TIP-OVER.

 WARNING	
	<p>Children have died from furniture tip-over. To reduce the risk of furniture tip-over:</p> <ul style="list-style-type: none">• ALWAYS install tip-over restraint provided.• NEVER put a TV on this product.• NEVER allow children to stand, climb or hang on drawers, doors, or shelves.• NEVER open more than one drawer at a time.• Place heaviest items in the lowest drawers.
	<p>Use of tip-over restraints may only reduce, but not eliminate, the risk of tip-over.</p>

FURNITURE POWER DISTRIBUTION CENTER

IMPORTANT SAFETY INSTRUCTIONS

Carefully read all instructions installing and operating fixture

IF YOU HAVE ANY QUESTIONS REGARDING THE PROPER INSTALLATION CONSULT A QUALIFIED ELECTRICIAN.



TO REDUCE THE RISK OF FIRE, ELECTRICAL SHOCK OR INJURY TO PERSONS, PLEASE FOLLOW THE NEXT:

- Use only insulated staples or plastic ties (not included) to secure the cords.
- Route and secure cords so that they will not be pinched or damaged when the desk is pushed up against the wall.
- Make sure cord is not pinched between desk and floor.
- Use the unit indoors only.
- Do not use an extension cord to connect this unit to a wall outlet.
- Use power strip with integral over-current protection to supply other electrical devices or accessories in desk.
- This unit must be plugged into a properly grounded outlet.
- The socket outlet should be installed near the equipment and should be easily accessible.
- Maximum load of connected equipment cannot exceed a total of 12 amps and 120 volts.
- Do not open or disassemble this unit for any reason.

SAVE THESE INSTRUCTIONS

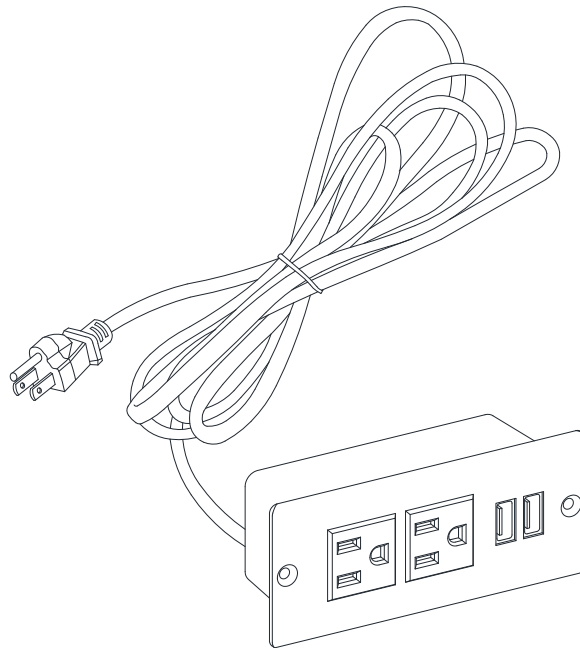

Furniture Power Distribution Unit User Guide

Please read this user guide before installing and using your power distribution Center.

INTRODUCTION

The integrated power and USB center offer 480 Mbps high transmission rate and can connect up to three devices, such as a digital camera, MP3 player, cell phone or wireless mouse.

SPECIFICATIONS

cULus listed, rated for: 120 V AC, 12 A, 60 HZ

NOTES

- To reach USB 2.1 high speed, your computer or host adapter card must support USB 2.1. This hub is also backwards compatible with USB 1.1.
- When using the hub with a computer that has a version 1.1 USB interface, all of the devices attached to the hub will run at USB 1.1 speed.

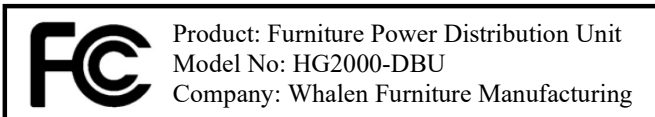

NOTE: This equipment has been tested and found to comply with the limits for a Class B digital device, pursuant to part 15 of the FCC Rules. These limits are designed to provide reasonable protection against harmful interference in a residential installation. This equipment generates, uses and can radiate radio frequency energy and, if not installed and used in accordance with the instructions, may cause harmful interference to radio communications. However, there is no guarantee that interference will not occur in a particular installation.

If this equipment does cause harmful interference to radio or television reception, which can be determined by turning the equipment off and on, the user is encouraged to try to correct the interference by one or more of the following measures:

- Reorient or relocate the receiving antenna.
- Increase the separation between the equipment and receiver.
- Connect the equipment into an outlet on a circuit different from that to which the receiver is connected.
- Consult the dealer or an experienced radio/TV technician for help.

This device complies with Part 15 of the FCC Rules. Operation is subject to the following two conditions: (1) This device may not cause harmful interference, and (2) this device must accept any interference received, including interference that may cause undesired operation.

CAN ICES-3 (B)/NMB-3(B)

This Class B digital apparatus complies with Canadian ICES-003.

Whalen Furniture Manufacturing
1578 Air Wing Road, San Diego, CA 92154, USA
1-866-942-5362

WARNINGS

- ! Your hub automatically shuts off any port with a low or excessive current.
- ! If USB Hub Current Limit Exceeded appears on your screen, disconnect the affected USB device, click Reset on the screen, and reconnect the device.
- ! If one of your hub ports is disabled, but USB Hub Current Limit Exceeded does not appear:
 - Disconnect and reconnect the affected device.
 - If the port still does not work, disconnect the hub and the device, and then reconnect.
- ! Keep your desktop hub dry; if it gets wet, wipe it dry immediately.
- ! Do not modify or tamper with your desktop hub's internal components. It may cause a malfunction and invalidate its warranty.
- ! Modifications not approved by the party responsible for compliance could void user's authority to operate the equipment.

Parts and Hardware List

Please read completely through the instructions and verify that all listed parts and hardware are present before beginning assembly.

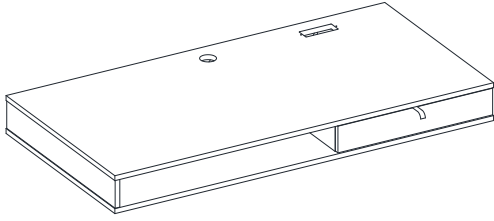

A- Desk Top (Qty. 1)

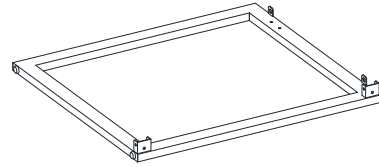

B- Left Side Frame (Qty. 1)

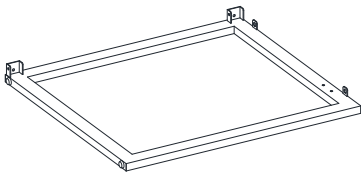

C- Right Side Frame (Qty. 1)

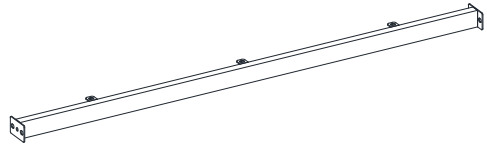

D- Upper Front Stretcher (Qty. 1)

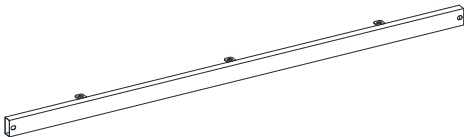

E- Upper Back Stretcher (Qty. 1)

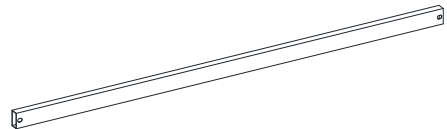

F- Bottom Back Stretcher (Qty. 1)



G- Cable Wheel (Qty. 1)

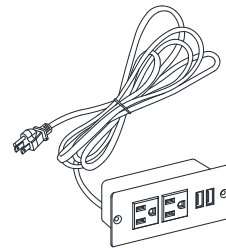

H- Power Center (Qty. 1)

Parts and Hardware List

Please read completely through the instructions and verify that all listed parts and hardware are present before beginning assembly.

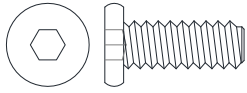

(1) 1/4" x 16 mm Bolt
(Qty. 22+1 extra)



(2) Lock Washer
(Qty. 20+1 extra)

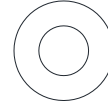

(3) Flat Washer
(Qty. 20+1 extra)



(4) M3.5 x 12 mm Screw
(Qty. 5+1 extra)

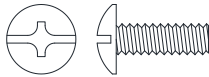

(5) 5/32" x 12 mm Bolt
(Qty. 2+1 extra)



(6) Grommet
(Qty. 1)

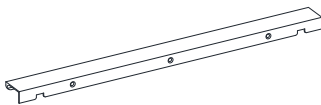

(7) Handle
(Qty. 1)

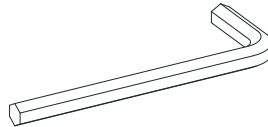

Hex Wrench
(Qty. 1)

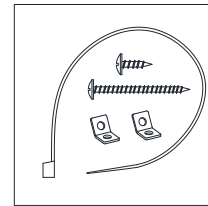

Tipping Restraint Hardware Kit (Qty. 1)
(Included in plastic bag)

Tools required (not included): Phillips screwdriver, stud finder, pencil, tape measure, power drill and 1/8 in drill bit.

Assembly Instructions

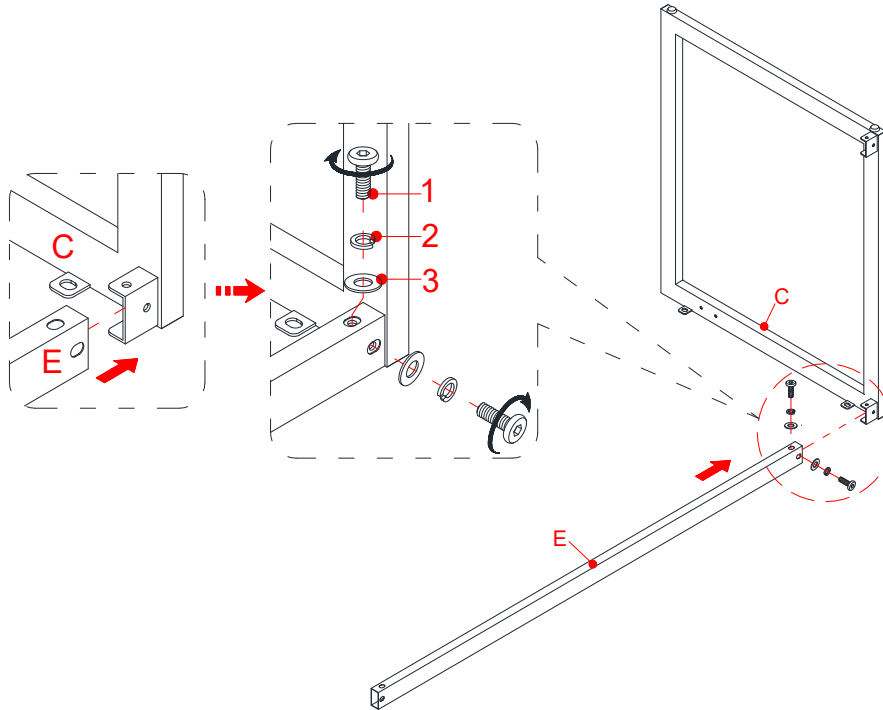

NOTE: Please do not fully tighten all bolts until you finish assembling all parts. Once assembled, go back and fully tighten all bolts. This will make the assembly easier.

1. Unpack the unit and confirm that you have all the hardware and required parts. Assemble the unit on a carpeted floor or the empty carton to avoid any scratch.
2. Attach the Upper Back Stretcher (E) to the Right Side Frame (C) with two 16 mm Bolts (1), two Lock Washers (2) and two Flat Washers (3). DO NOT fully tighten the Bolts in this step.

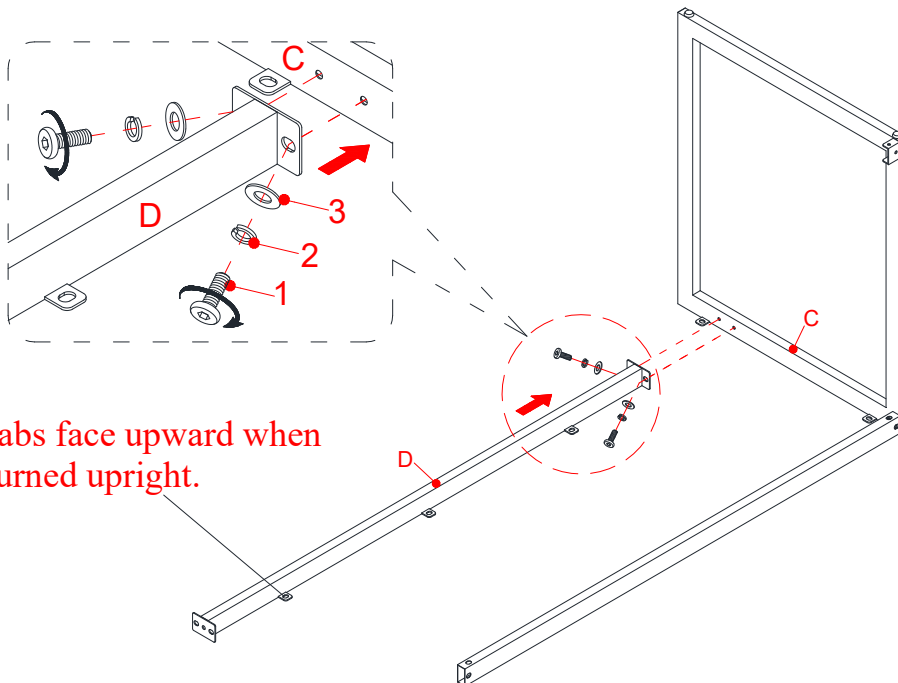

3. Attach the Upper Front Stretcher (D) to the Right Side Frame (C) using two 16 mm Bolts (1), four Washers (2 and 3) as shown.

Assembly Instructions

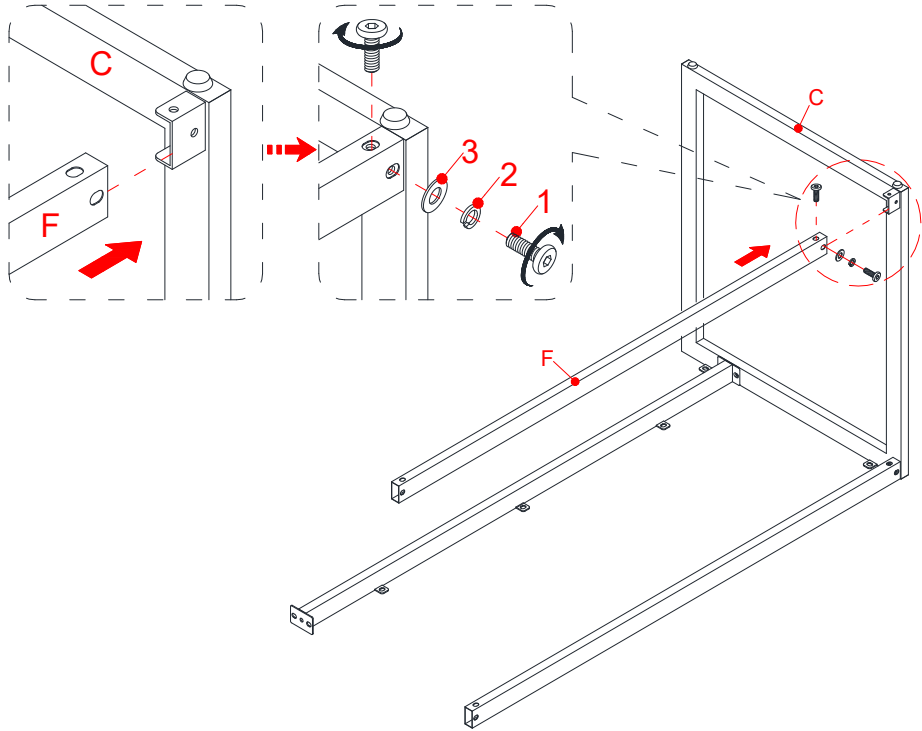

- 4. Fit the Bottom Back Stretcher (F) onto the U-shaped bracket on the bottom of the Right Side Frame (C) as shown, using two 16 mm Bolts (1) and two Washers (2 and 3). Fasten it into place.

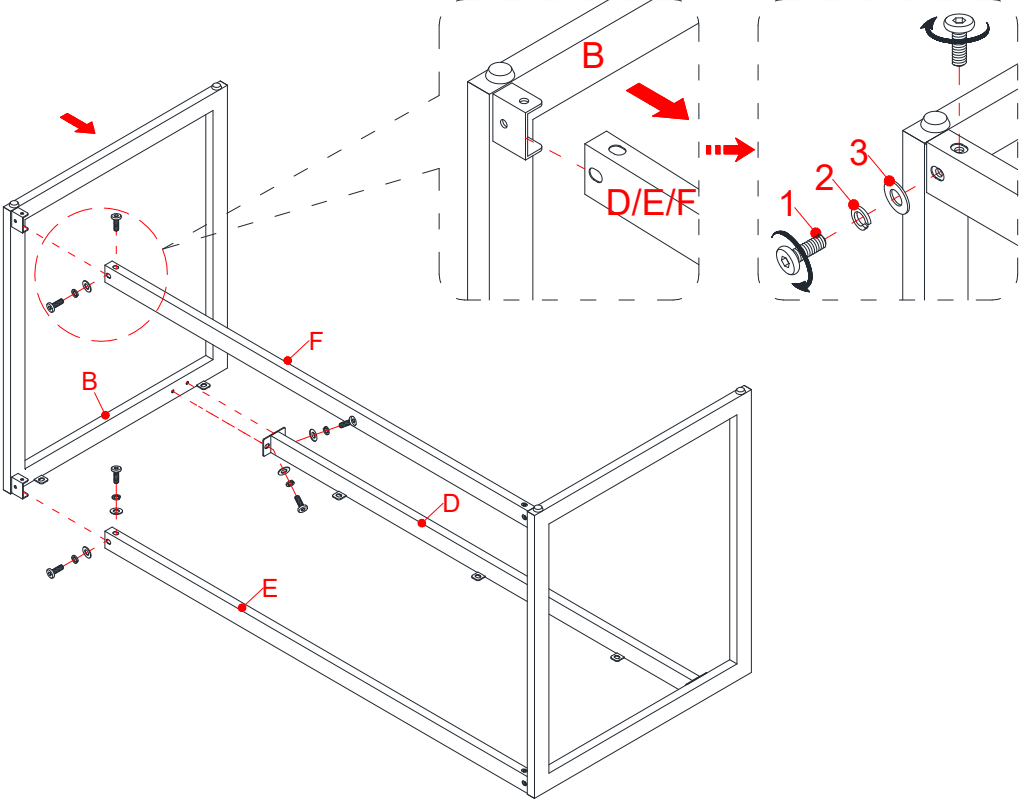

- 5. Repeat the same procedure to attach Left Side Frame (B) at the opposite end.

Assembly Instructions

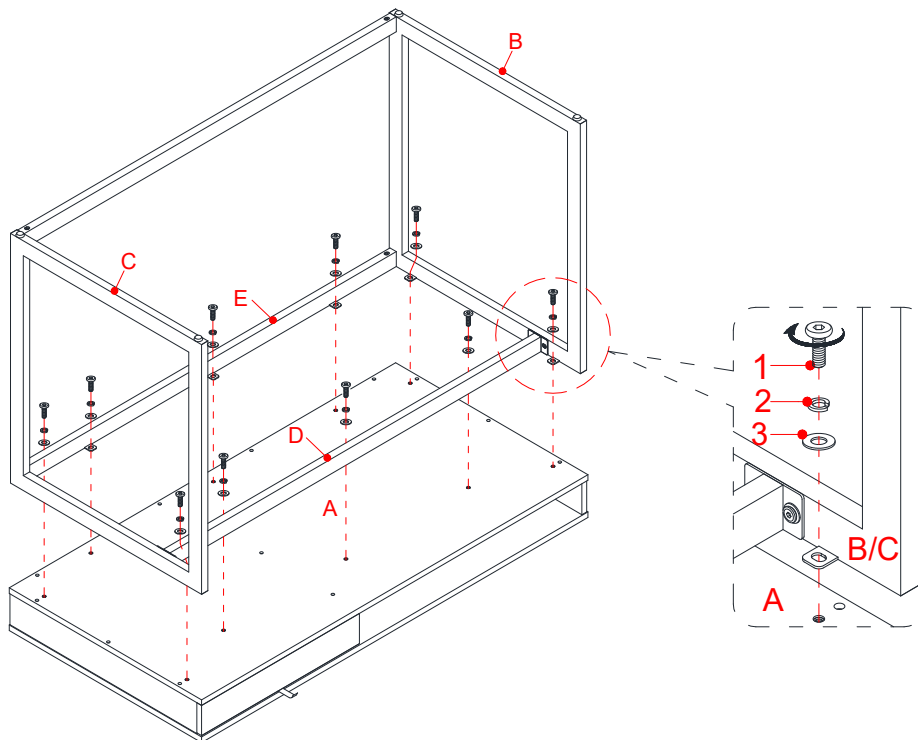

6. Place the Desk Top (A) upside down on a level and scratch-free surface.
7. Align and attach the previous assembly unit to the Desk Top (A) with ten 16 mm Bolts (1), ten Lock Washers (2) and ten Flat Washers (3).

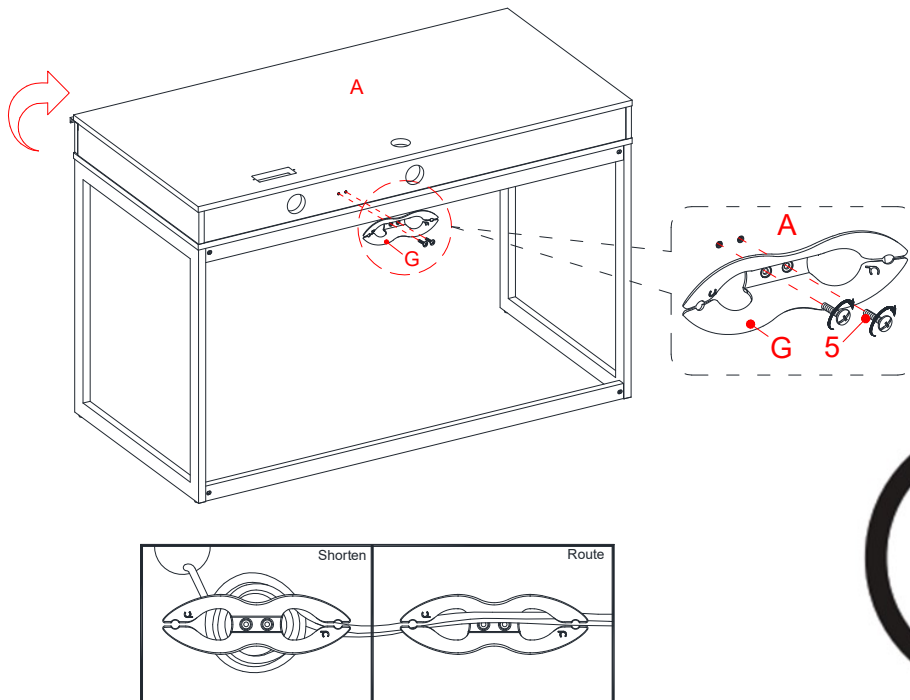

8. Ask for assistance to stand the unit upright.
9. Align and attach the Cable Wheel (G) to the backside of the Desk Top (A) with two 12 mm Bolts (5).
NOTE: You can use the Cable Wheels to help keep your cables and cords organized.

Assembly Instructions

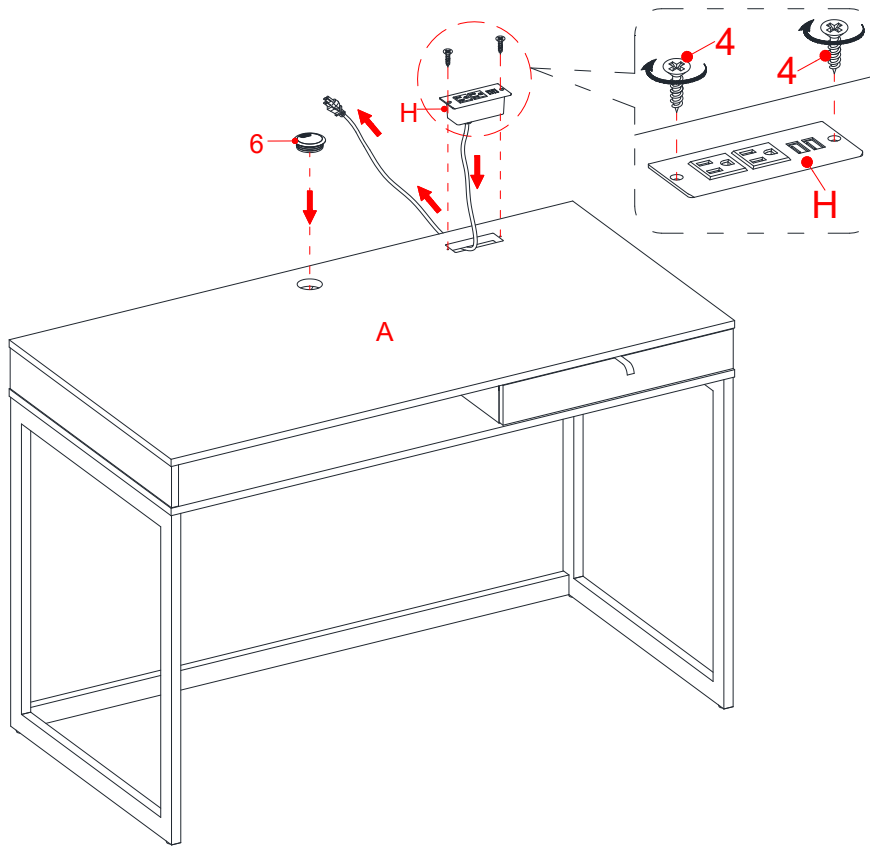

10. Feed the wire of Power Center (H) through the cutout of the Desk Top (A) and push into the cutout from top of Desk Top, secure it in place with two 12 mm Screws (4). Make sure the wire is not pinched.
11. Place the Grommet (6) over the hole on Desk Top (A).

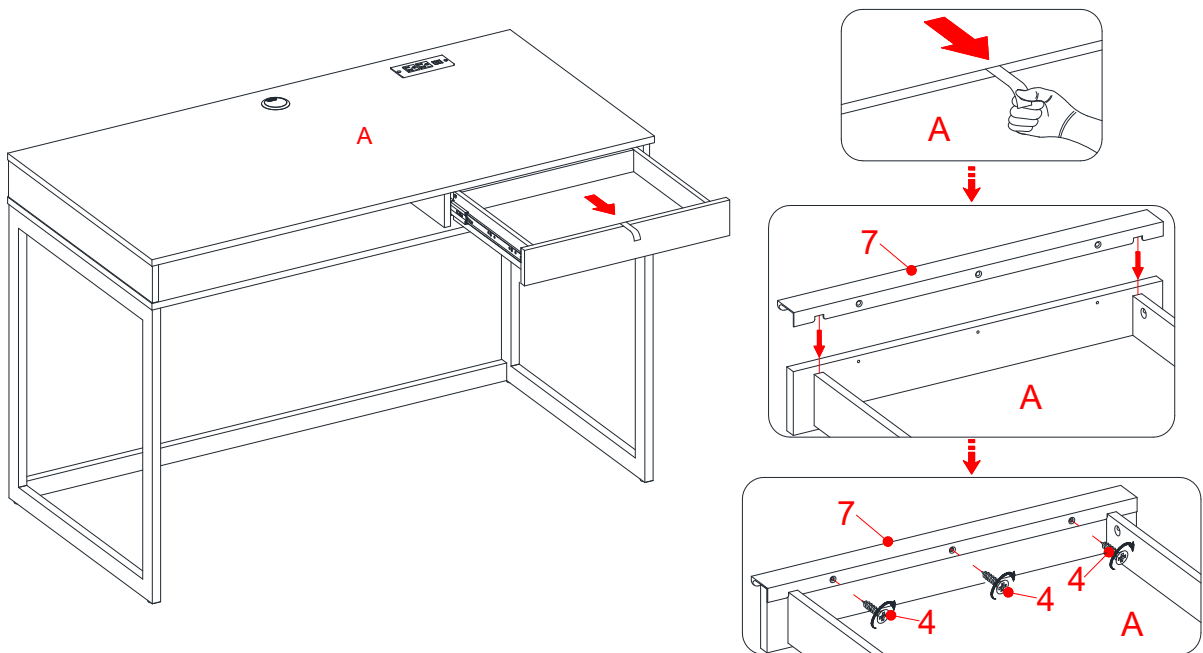

12. Open the drawer and attach the Handle (7) to the top of the drawer front panel with three 12 mm Screws.

Assembly Instructions

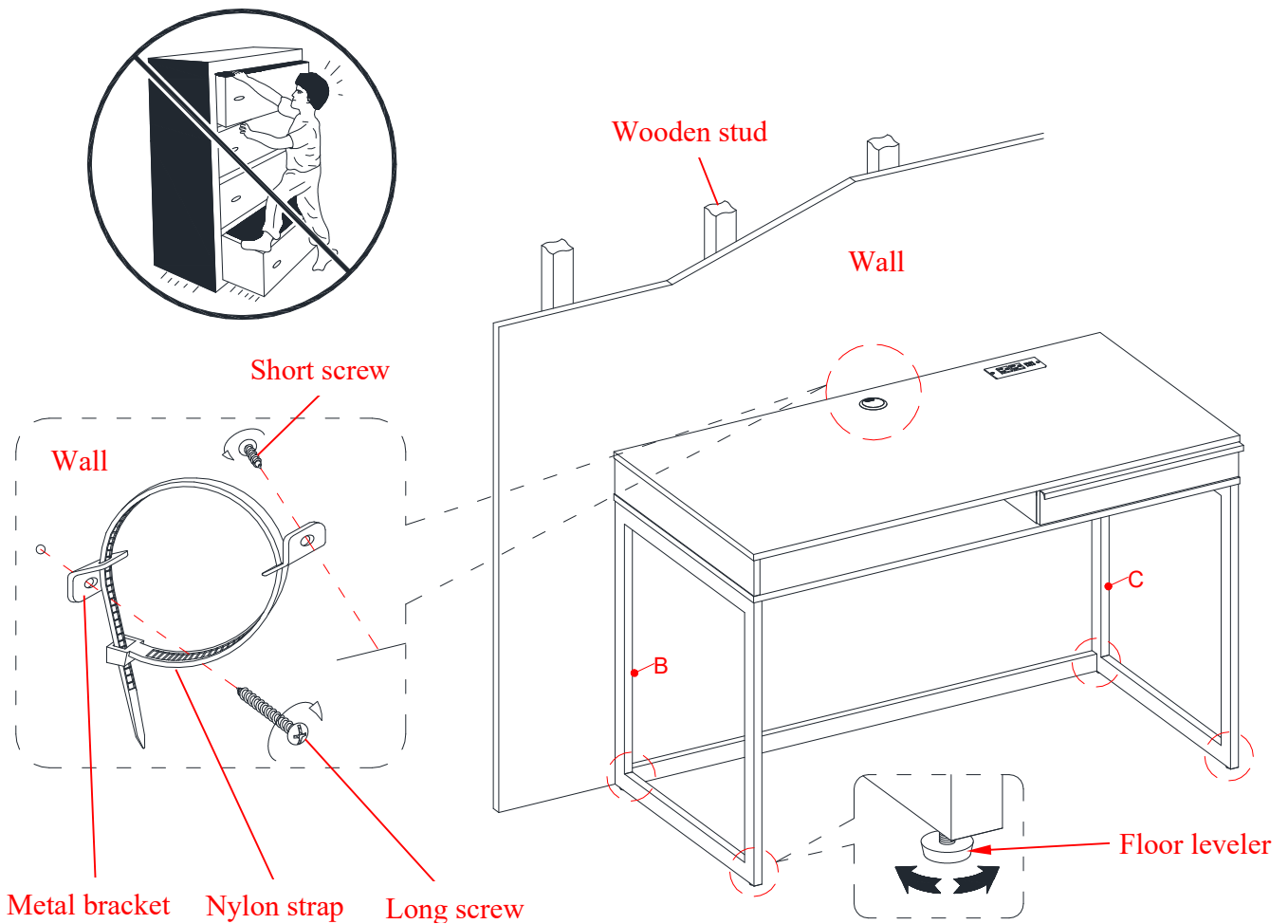

Tools required (not provided): Phillips screwdriver, stud finder, tape measure, pencil, power drill and 1/8" drill bit.

13. Position the unit at the desired location against a wall. If necessary, adjust the Floor Levelers at the bottom of the Side Frames (B and C) to level the unit.
14. Now, follow the instructions printed on the plastic bag containing the Tipping Restraint Hardware to attach the tip-over restraints to the unit and the wall.

NOTE: The tipping restraint hardware included is for wooden stud wall construction. It must be attached to a wall stud. Depending upon your wall construction, different anchor hardware maybe required. Please contact your local hardware store for assistance. Young children can be seriously injured by tipping furniture. You must install the tipping restraint hardware with the unit to prevent the unit from tipping, causing any accidents or damage. The tipping restraints are intended only as a deterrent, they are not a substitute for proper adult supervision. The tipping restraints are not earthquake restraints. If you wish to add the extra security of earthquake restraints, they must be purchased and installed separately.

15. The unit is now ready for use.

Care and Maintenance

- Use a soft, clean cloth that will not scratch the surface when dusting.
- Gently rub the surface with a soft dry cloth, soft damp cloth, or soft damp cloth with neutral detergent, and then dry it well.
- Strong Alkaline detergents or acidic detergents are not recommended to use.
- Sponges containing abrasive agents or fibers are not recommended to use.
- Use of furniture polish is not necessary. Should you choose to use polish, test first in an inconspicuous area.
- Using solvents of any kind on your furniture may damage the finish.
- Never use water to clean your furniture as it may cause damage to the finish.
- Always use coasters under beverage glasses and flowerpots.
- Liquid spills should be removed immediately. Using a soft, clean cloth, blot the spill gently. Avoid rubbing.
- Always use protective pads under hot dishes and plates. Heat can cause chemical changes that may create spotting within the furniture finish.
- In the event that your furniture is stained or otherwise damaged during use, we recommend that you call a professional to repair your furniture.
- Check bolts/screws periodically and tighten them if necessary.

Further advice about wood furniture care

It is best to keep your furniture in a climate-controlled environment. Extreme temperature and humidity changes can cause fading, warping, shrinking and splitting of wood. It is advised to keep furniture away from direct sunlight as sun may damage the finish.

Proper care and cleaning at home will extend the life of your purchase. Following these important and helpful tips will enhance your furniture as it ages.

We hope you enjoy your purchase for many years.
Thank you for your purchase!

QUALITY GUARANTEE

We are confident that you will be delighted with your Whalen Furniture purchase.

Should this product be defective in workmanship or materials or fail under normal use, we will repair or replace it for up to one (1) year from date of purchase. Every Whalen Furniture product is designed to meet your highest expectations. We guarantee that you will immediately see the value of our fine furniture.

This warranty gives you specific legal rights and you may also have other rights which vary from State to State or province to province.

Whalen Furniture Manufacturing
1578 Air Wing Road, San Diego CA, 92154, USA
Customer Service: 866-942-5362
8:30 a.m. - 4:30 p.m., PST, Monday to Friday
www.whalenfurniture.com