



LOT NUMBER: \_\_\_\_\_  
DATE PURCHASED: \_\_\_/\_\_\_/\_\_\_

# Springfield Modular Desk with Set of Bookcases

Model # SPLS-SPMDBK-HW



**ADULT ASSEMBLY REQUIRED DUE TO THE PRESENCE OF SMALL PARTS, SHARP POINTS, SHARP EDGES AS RECEIVED**

If you have any questions regarding assembly or if parts are missing, DO NOT return this item to the store where it was purchased. Please call our toll-free customer service number and have your instructions and parts list ready to provide the model name, part name or factory number:

**1-866-942-5362**

Pacific Standard Time: 8:30 a.m. - 4:30 p.m., Monday - Friday  
Or visit our web site 24 hours a day, 7 days a week for product assistance at

**[www.whalenfurniture.com](http://www.whalenfurniture.com)**

Or e-mail your request to **[parts@whalenfurniture.com](mailto:parts@whalenfurniture.com)**

**THIS INSTRUCTION BOOKLET CONTAINS IMPORTANT SAFETY INFORMATION.  
PLEASE READ AND KEEP FOR FUTURE REFERENCE.**

Date 2021-02-04 Rev. 0001-A

## MAXIMUM RECOMMENDED WEIGHT LOADS

MANUFACTURER: Whalen Furniture Manufacturing  
CATALOG: Springfield Modular Desk with Set of Bookcases  
MODEL # SPLS-SPMDBK-HW

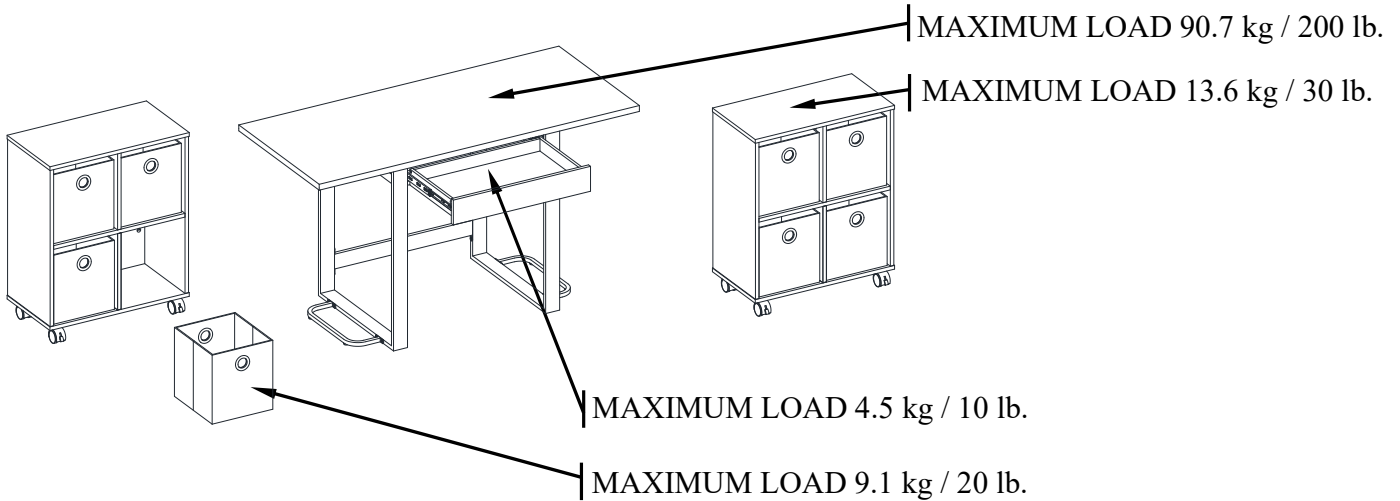

### **⚠ WARNING**

THIS UNIT IS INTENDED ONLY FOR USE WITHIN THE MAXIMUM WEIGHTS INDICATED. USE WITH LOAD HEAVIER THAN THE MAXIMUM WEIGHTS INDICATED MAY RESULT IN INSTABILITY, CAUSING POSSIBLE INJURY.

### **SPECIAL NOTE**

Please read the instruction sheets completely before assembly. Examine all packaging material before discarding carton. Remove any remaining staples from the carton before discarding. Remove all parts from carton and separate into groups as indicated on part list. Please ensure all parts are included prior to assembly. Use of power tools to complete assembly is not recommended.

## IMPORTANT

**Before you begin:** Open, identify and count all parts prior to assembly. Lay out parts on a flat and non-abrasive surface. You will need the parts identified on page 5, 6 and 7 of this instruction manuals.

**NOTE:** IT IS VERY IMPORTANT TO USE GLUE WITH DOWELS. EXCESS GLUE CAN BE WIPED OFF WITH DAMP CLOTH.

Insert the Dowel at least half way by tapping lightly with a rubber mallet, IF NECESSARY.

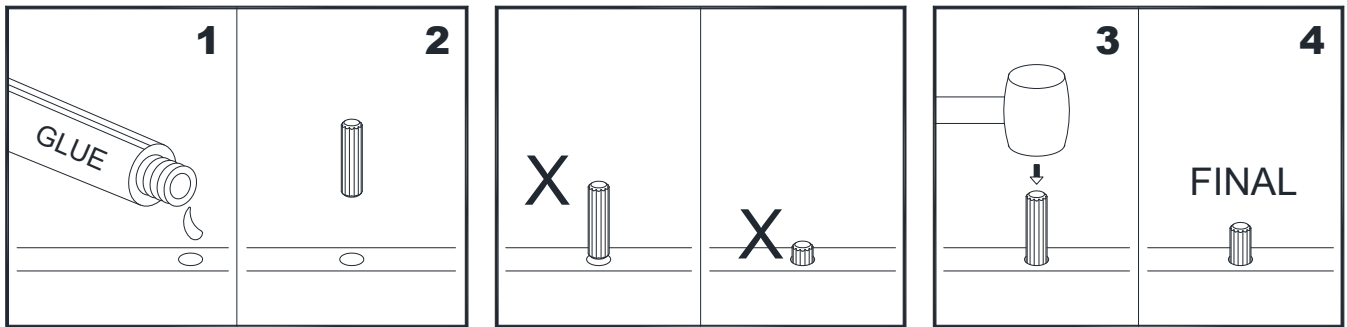

## CAM LOCK SYSTEM OPERATION

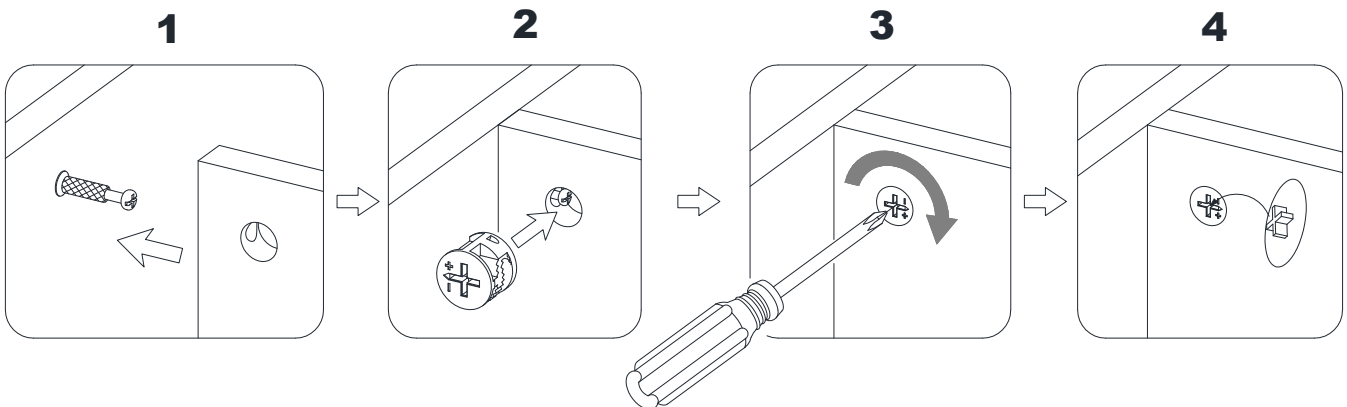

## HOW THE KNOCK DOWN (KD) ASSEMBLY SYSTEM WORKS

1. Screw the Cam Bolt into the pre-drilled small holes on the panel. Connect both panels together; making sure the Cam Bolt goes into the pre-drilled hole at the end of the panel with the Cam Lock.
2. Insert the Cam Lock into the pre-drilled large hole in the panel. Make sure the arrow on the Cam Lock is pointed towards the Cam Bolt.
3. Once the Cam Bolt is connected inside the Cam Lock, take a Phillips screwdriver (not included) and tighten the Cam Lock clockwise.
4. Put the PVC Cover onto the visible Cam Locks to conceal the cam.

**You are now ready to assemble the KD unit.**

# FURNITURE TIPPING RESTRAINT

**YOUNG CHILDREN MAY BE INJURED BY TIPPING FURNITURE AND YOU MUST USE THIS TIPPING RESTRAINT TO ATTACH THIS UNIT TO THE WALL, TO PREVENT ACCIDENTS AND/OR INJURIES.**

**THIS HARDWARE MUST BE PROPERLY INSTALLED (FOLLOW ALL DIRECTIONS IN ORDER ON THIS INSTRUCTIONS), TO PROVIDE PROTECTION AGAINST THE UNEXPECTED TIPPING OF FURNITURE DUE TO IMPROPER USE.**

**THIS PRODUCT IS ONLY A DETERRENT. IT IS NOT A SUBSTITUTE FOR PROPER ADULT SUPERVISION. USE OF TIP-OVER RESTRAINTS MAY ONLY REDUCE, BUT NOT ELIMINATE, THE RISK OF TIP-OVER.**

 <b>WARNING</b>	
	<p><b>Children have died from furniture tip-over. To reduce the risk of furniture tip-over:</b></p> <ul style="list-style-type: none"><li>• ALWAYS install tip-over restraint provided.</li><li>• NEVER put a TV on this product.</li><li>• NEVER allow children to stand, climb or hang on drawers, doors, or shelves.</li><li>• NEVER open more than one drawer at a time.</li><li>• Place heaviest items in the lowest drawers.</li></ul>
	<p><b>Use of tip-over restraints may only reduce, but not eliminate, the risk of tip-over.</b></p>

## Parts and Hardware List

Please read completely through the instructions and verify that all listed parts and hardware are present before beginning assembly.

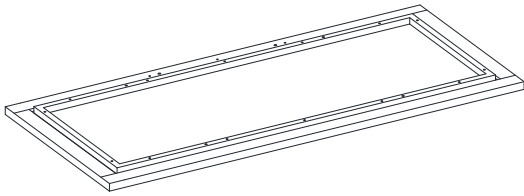

A- Desk Top (Qty. 1)

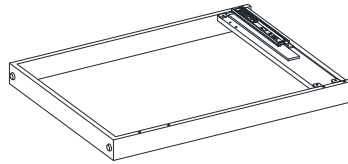

B- Left Side Frame (Qty. 1)

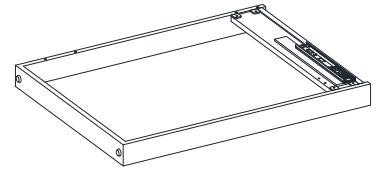

C- Right Side Frame (Qty. 1)

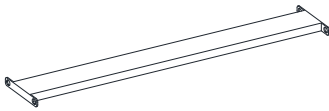

D- Lower Back Stretcher (Qty. 1)

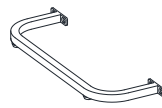

E- Stabilizer (Qty. 2)

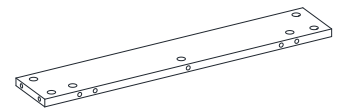

F- Upper Back Stretcher (Qty. 1)



G- Upper Front Stretcher (Qty. 1)

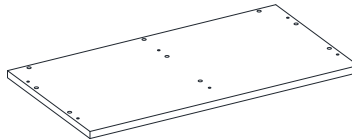

H- Bookcase Top Panel (Qty. 2)

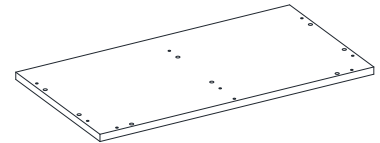

I- Bookcase Bottom Panel (Qty. 2)

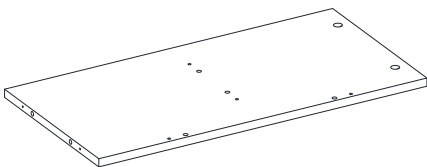

J- Bookcase Left Side Panel  
(Qty. 2)

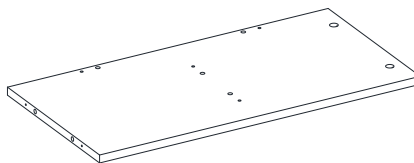

K- Bookcase Right Side Panel  
(Qty. 2)

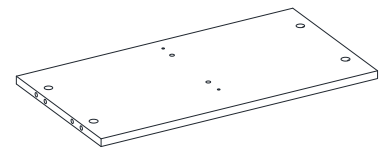

L- Bookcase Middle Shelf  
(Qty. 2)

## Parts and Hardware List

Please read completely through the instructions and verify that all listed parts and hardware are present before beginning assembly.

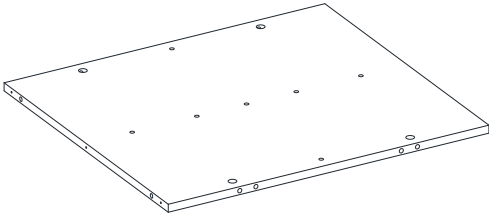

M- Bookcase Back Panel  
(Qty. 2)

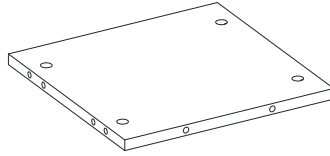

N- Bookcase Upper Partition Panel  
(Qty. 2)

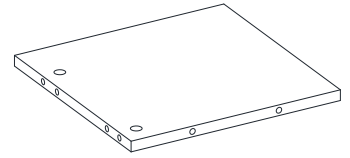

O- Bookcase Lower Partition Panel  
(Qty. 2)

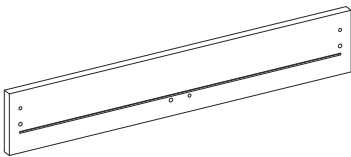

P- Drawer Front Panel (Qty. 1)

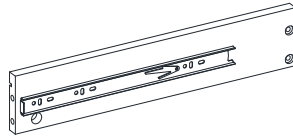

Q- Drawer Left Side Panel (Qty. 1)

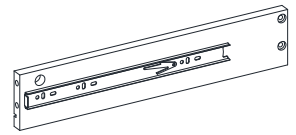

R- Drawer Right Side Panel (Qty. 1)

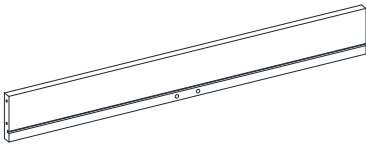

S- Drawer Back Panel (Qty. 1)

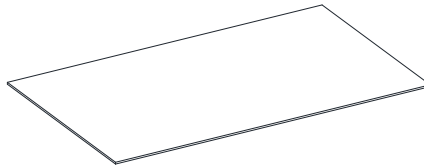

T- Drawer Bottom Panel (Qty. 1)

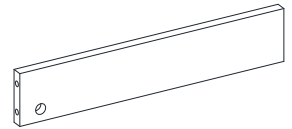

U- Drawer Bottom Support (Qty. 1)

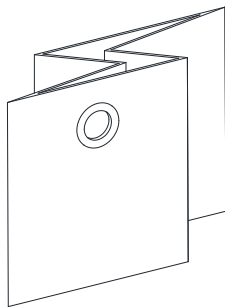

V- Storage Basket (Qty. 8)

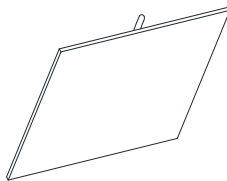

W- Basket Flooring (Qty. 8)

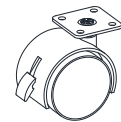

X- Locking Caster (Qty. 4)

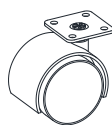

Y- Swivel Caster (Qty. 4)

## Parts and Hardware List

Please read completely through the instructions and verify that all listed parts and hardware are present before beginning assembly.



(1) Small Cam Lock  
(Qty. 3+1 extra)

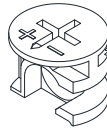

(2) Large Cam Lock  
(Qty. 47+2 extra)

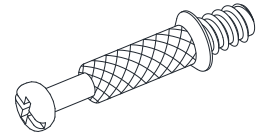

(3) Cam Bolt  
(Qty. 46+2 extra)



(4) M6 x 30 mm Wood Dowel  
(Qty. 3+1 extra)

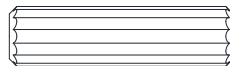

(5) M8 x 30 mm Wood Dowel  
(Qty. 74+2 extra)



(6) M4 x 15 mm Pan Head Screw  
(Qty. 32+1 extra)

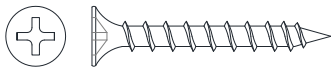

(7) M3.5 x 32 mm Screw  
(Qty. 24+1 extra)

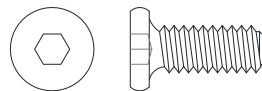

(8) 1/4" x 15 mm Bolt  
(Qty. 12+1 extra)

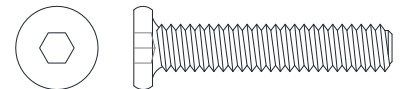

(9) 1/4" x 32 mm Bolt  
(Qty. 4+1 extra)



(10) Lock Washer  
(Qty. 16+1 extra)

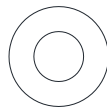

(11) Flat Washer  
(Qty. 16+1 extra)

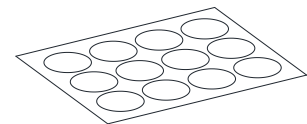

(12) PVC Cover  
(Qty. 28)

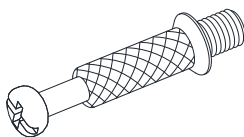

(13) Cam Bolt  
(Qty. 4+1 extra)

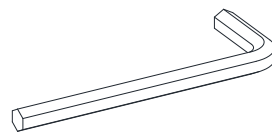

Hex Wrench  
(Qty. 1)

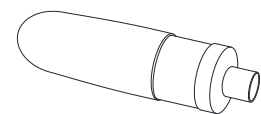

Glue  
(Qty. 3)

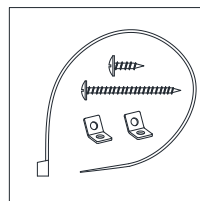

Tipping Restraint Hardware Kit (Qty. 1)  
(Included in plastic bag)

Tools required (not included): Phillips screwdriver, stud finder, pencil, tape measure, power drill and 1/8 in drill bit.

## Assembly Instructions

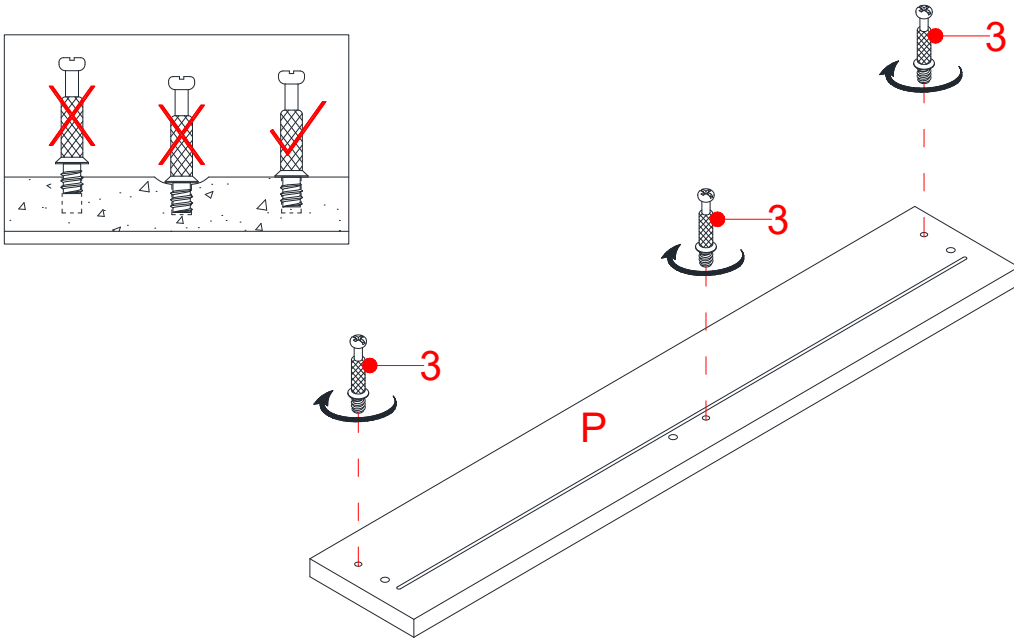

**NOTE:** Please do not fully tighten all bolts until you finish assembling all parts. Once assembled, go back and fully tighten all bolts. This will make the assembly easier.

1. Unpack the unit and confirm that you have all the hardware and required parts. Assemble the unit on a carpeted floor or the empty carton to avoid any scratch.
2. Securely screw the Cam Bolts (3) into the designated small holes on the Drawer Front Panel (P) with a Phillips screwdriver. DO NOT overtighten the Cam Bolts.

**NOTE:** Screw-in cam bolts must be screwed down flush.

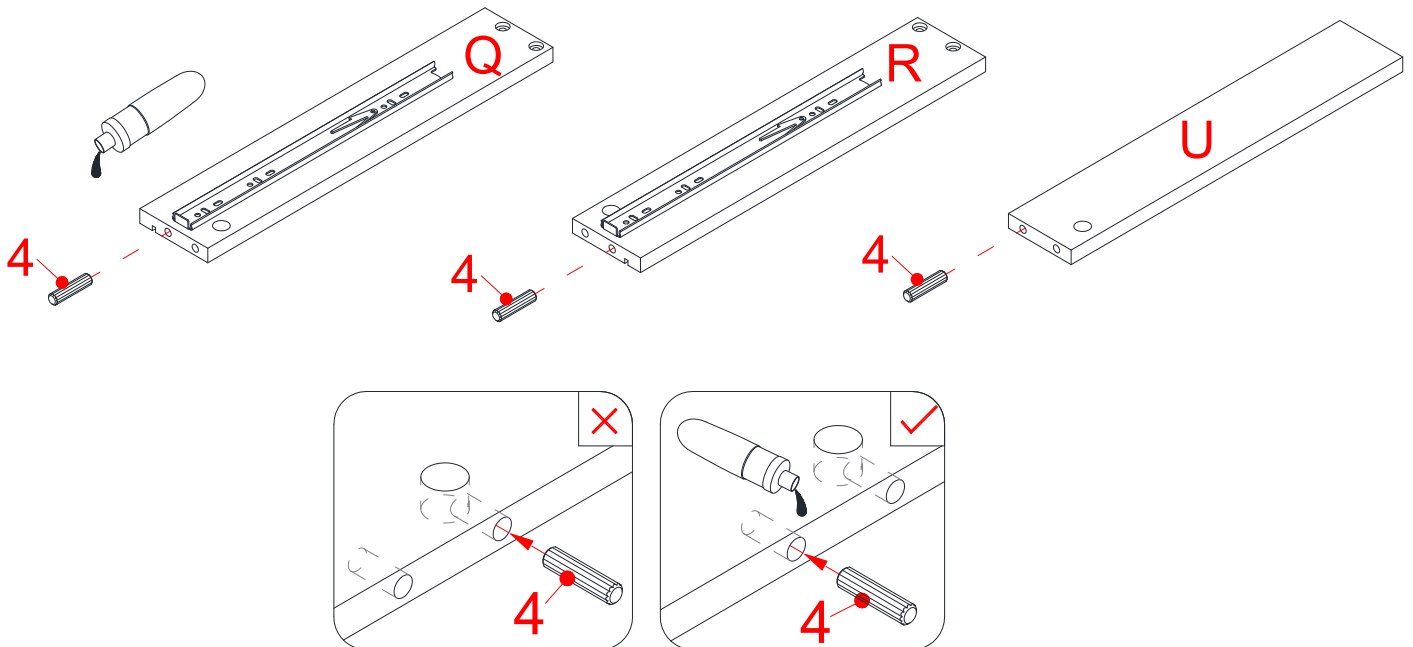

3. Glue the small Wood Dowels (4) into the pre-drilled holes on the end of both Drawer Side Panels (Q and R) and Drawer Bottom Support (U). Make sure that you use a small amount of glue with both ends of all dowels.

**NOTE:** It is very important to use a small amount of glue on both ends of dowels.



# Assembly Instructions

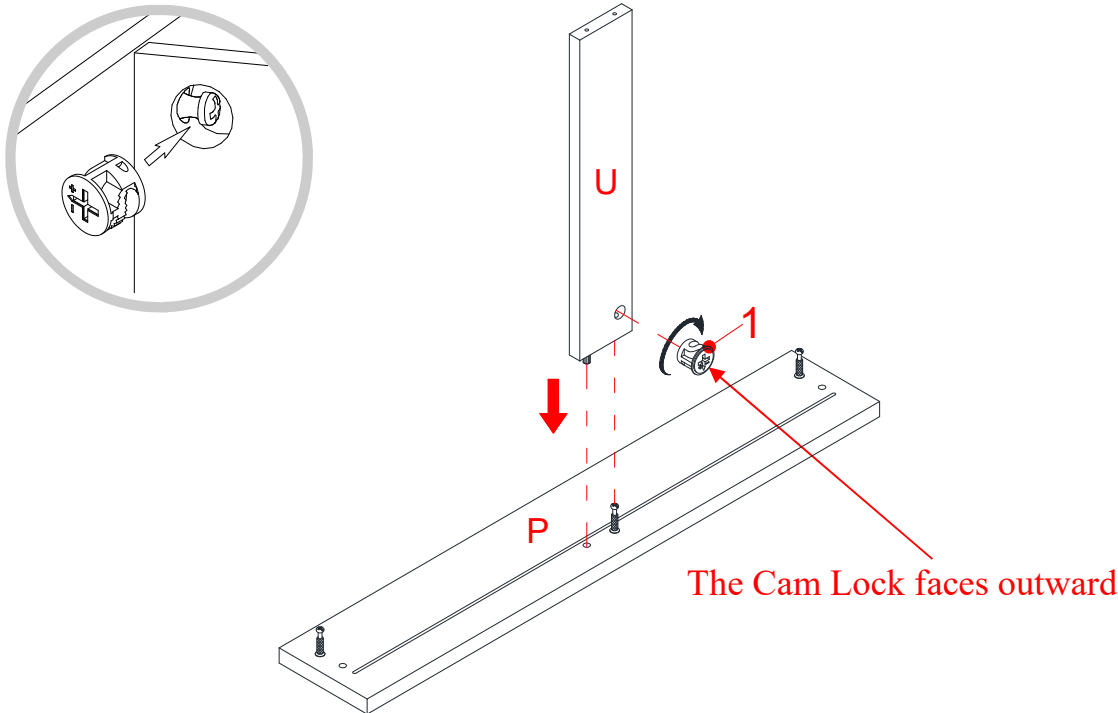

- 4. Align and attach the Drawer Bottom Support (U) to the Drawer Front Panel (P) by engaging one Small Cam Lock (1). (Refer to page 3 on Cam Lock system operation supplement).

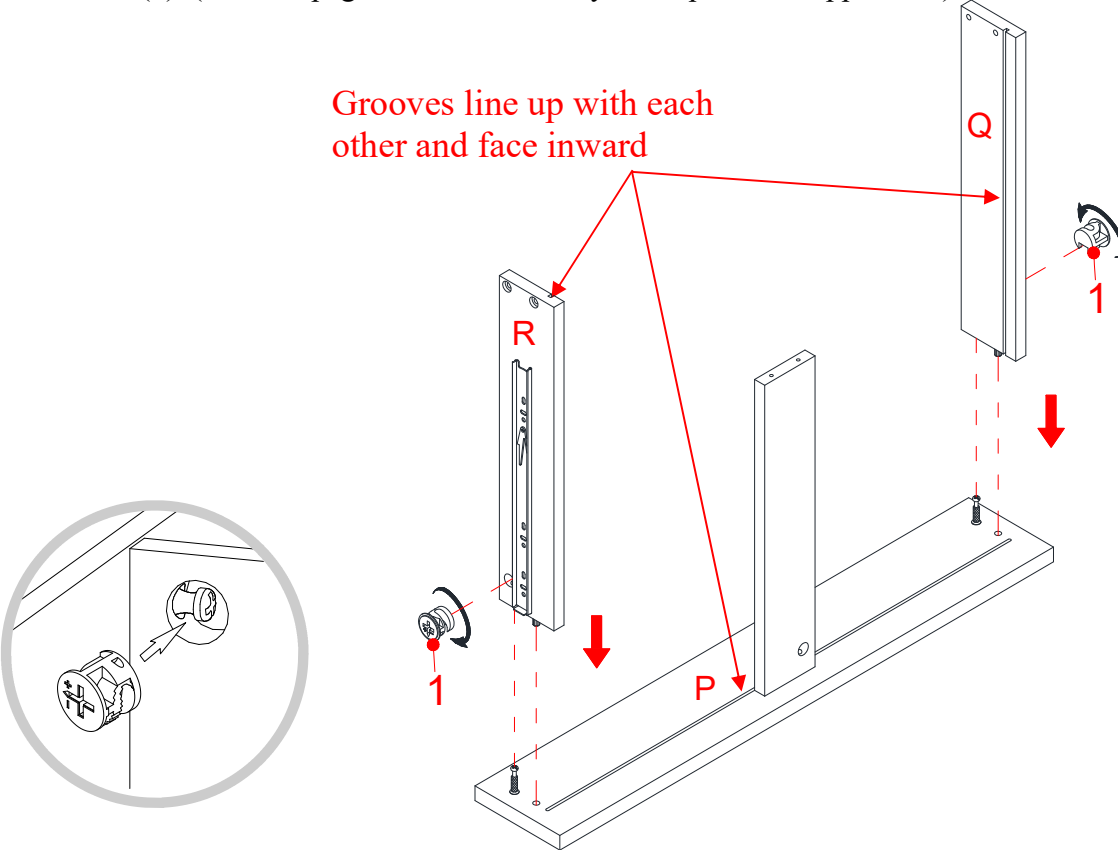

- 5. Align and attach the Drawer Side Panels (Q and R) to the Drawer Front Panel (P) with two Small Cam Locks (1).

## Assembly Instructions

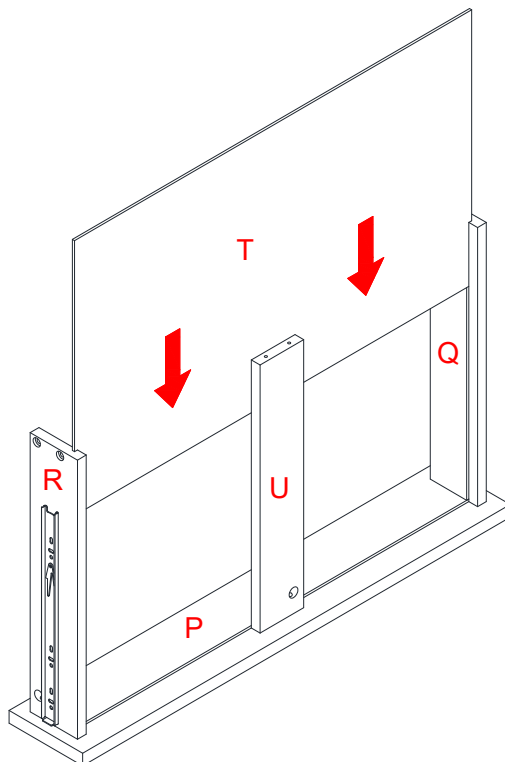

- Slide the Drawer Bottom Panel (T) into the grooves between the Drawer Side Panels (Q and R) until fully inserted into the groove of the Drawer Front Panel (P).

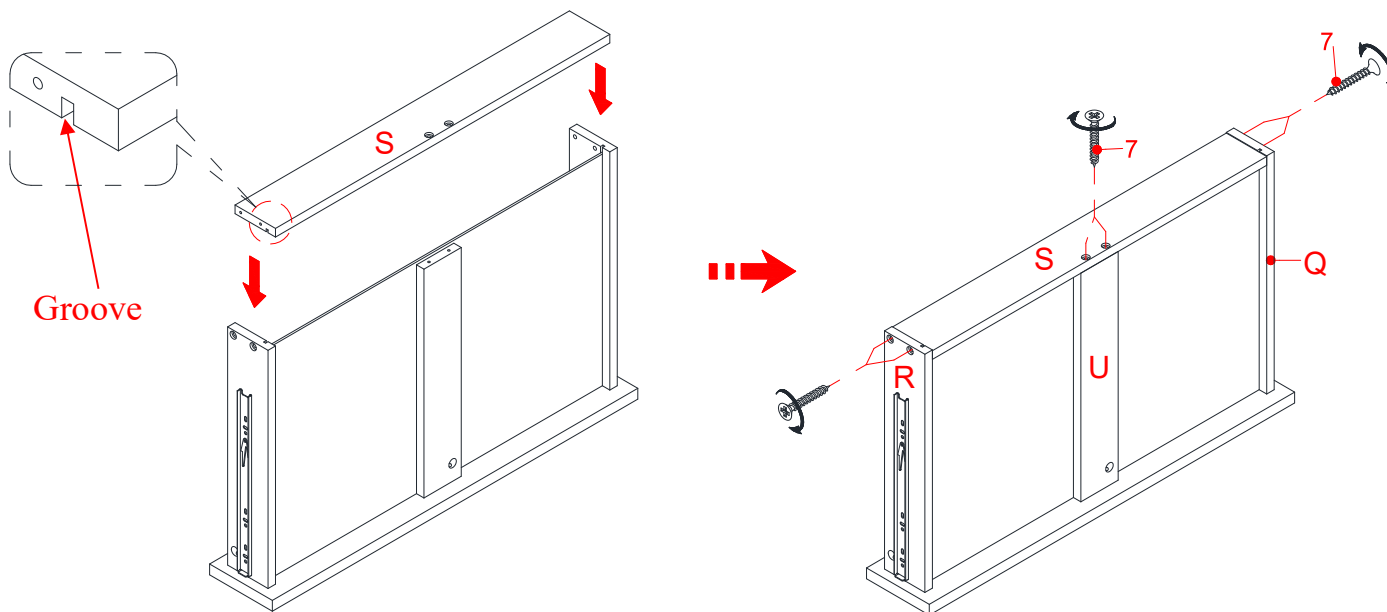

- Fasten the Drawer Back Panel (S) to the Drawer Side Panels (Q and R) and the Drawer Bottom Support (U) with six 32 mm Screws (7). Make sure that the Drawer Bottom Panel (T) fits securely into the groove of the Drawer Back Panel (S). Tighten all the screws with a Phillips screwdriver.

## Assembly Instructions

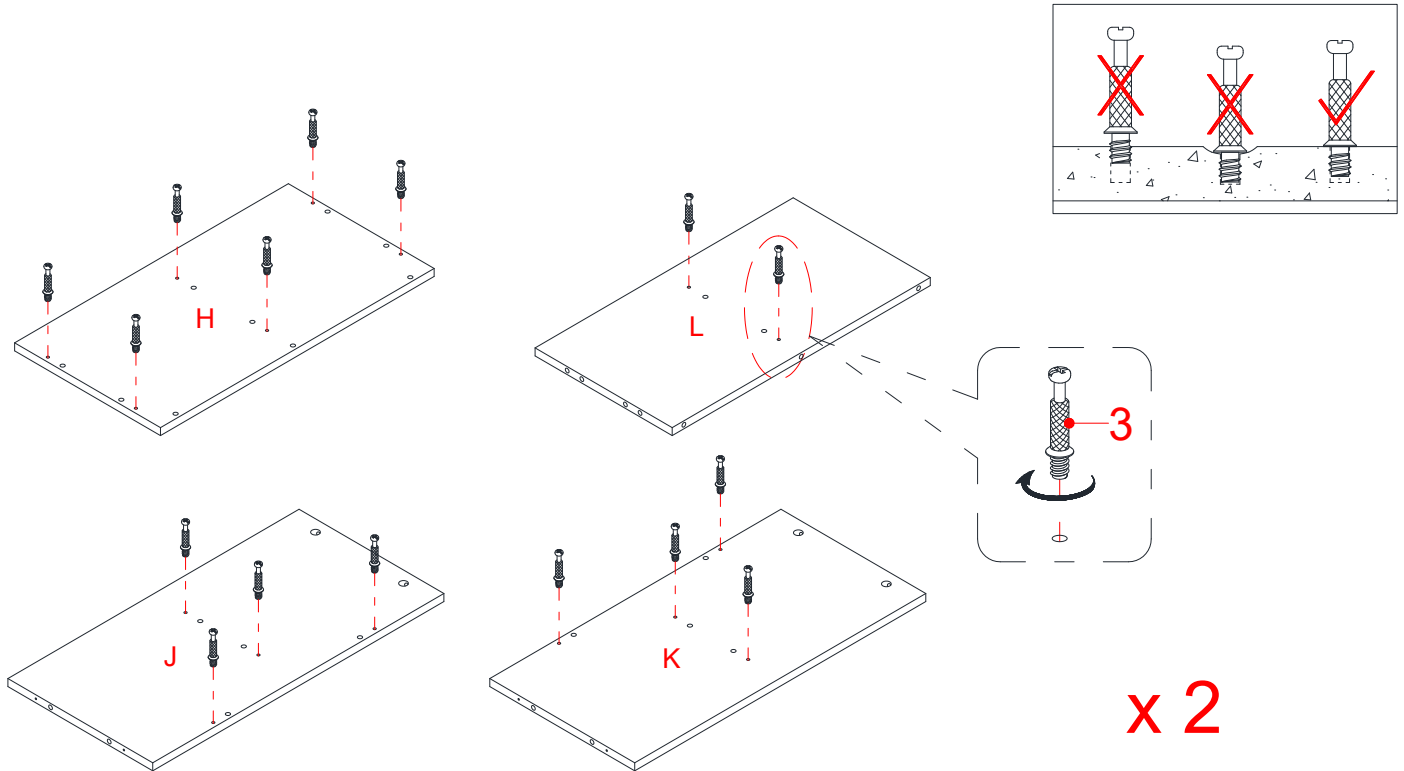

8. Securely screw the Cam Bolts (3) into the designated small holes on the Bookcase Top Panels (H), Bookcase Side Panels (J and K) and Bookcase Middle Shelves (L) with a Phillips screwdriver. DO NOT overtighten the Cam Bolts.

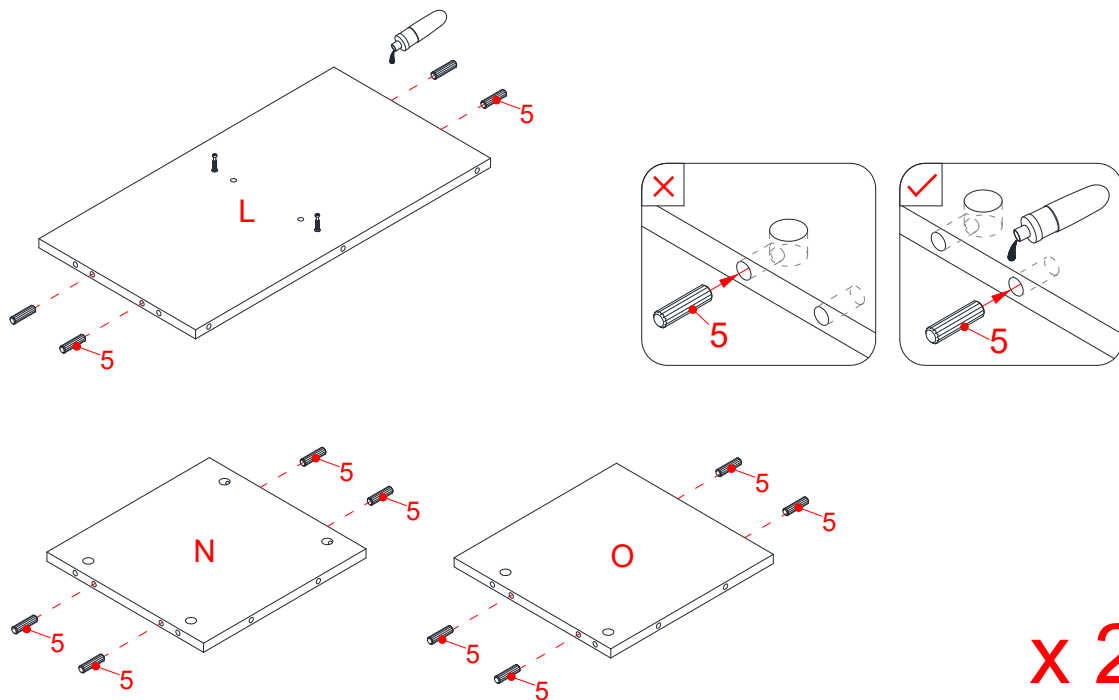

9. Glue the Large Wood Dowels (5) into the inner holes on the Bookcase Middle Shelves (L) and Bookcase Partition Panels (N and O).

## Assembly Instructions

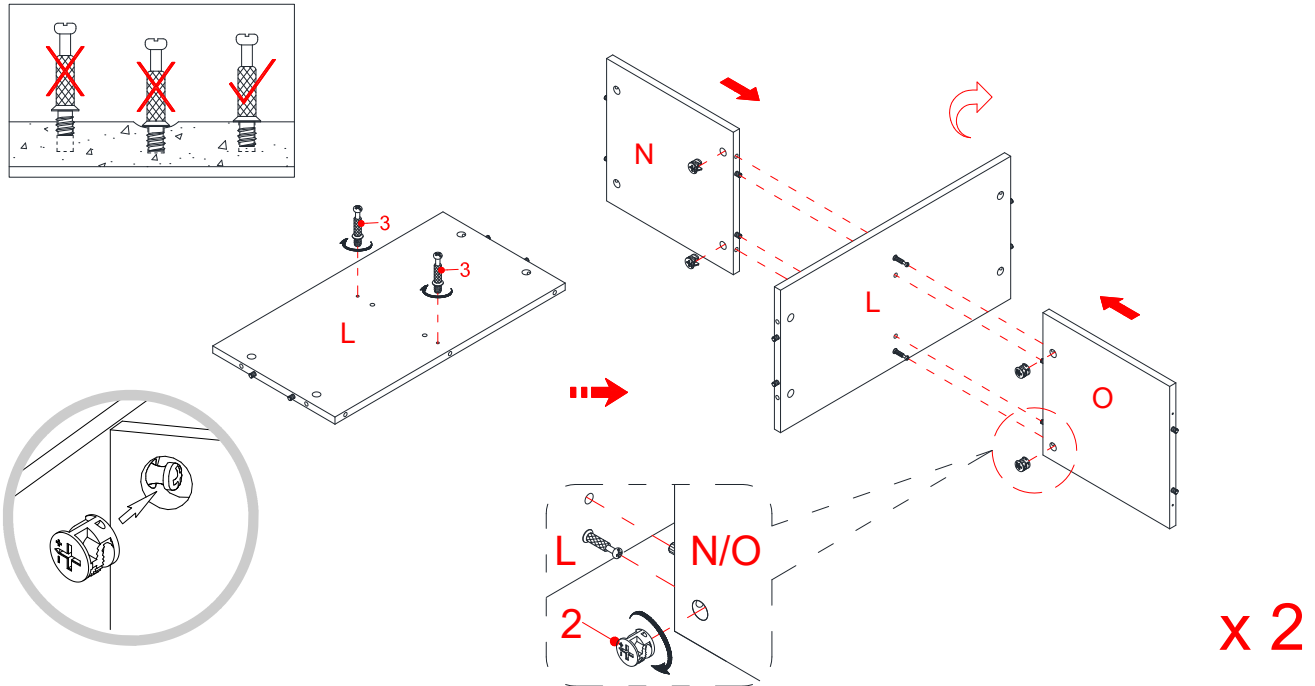

10. Securely screw the Cam Bolts (3) into the designated small holes on the Bookcase Middle Shelves (L) with a Phillips screwdriver.
11. Attach the Bookcase Partition Panels (N and O) to the Bookcase Middle Shelves (L) by engaging two Large Cam Locks (2). Make sure the wood dowel holes for the Bookcase Back Panel (M) point in the same direction.

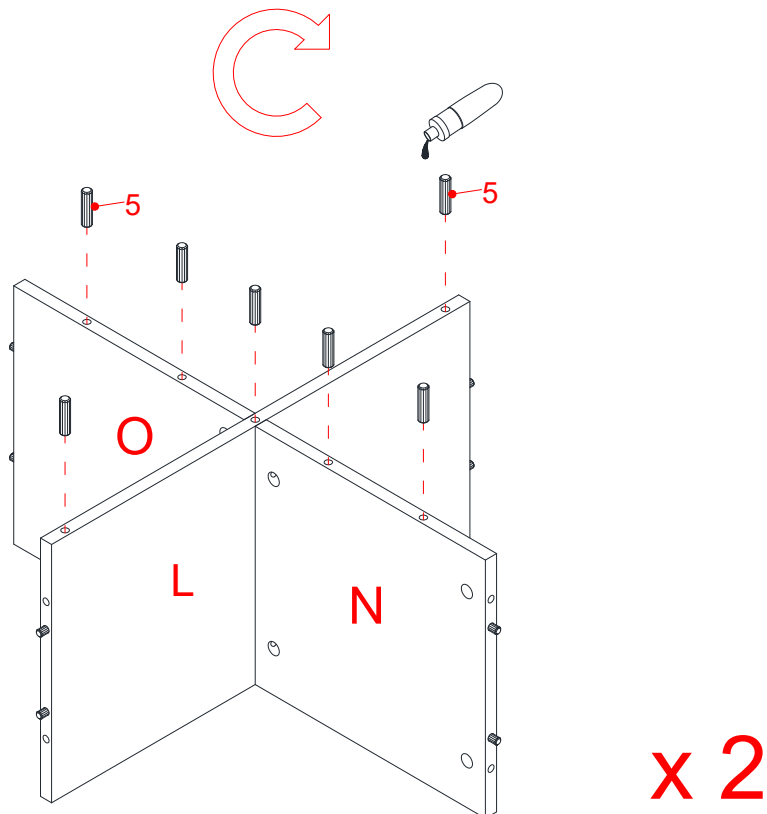

12. Glue the Large Wood Dowels (5) into the pre-drilled holes on the Bookcase Middle Shelves (L) and Bookcase Partition Panels (N and O).

## Assembly Instructions

The cam lock holes and pilot holes point in the same direction.

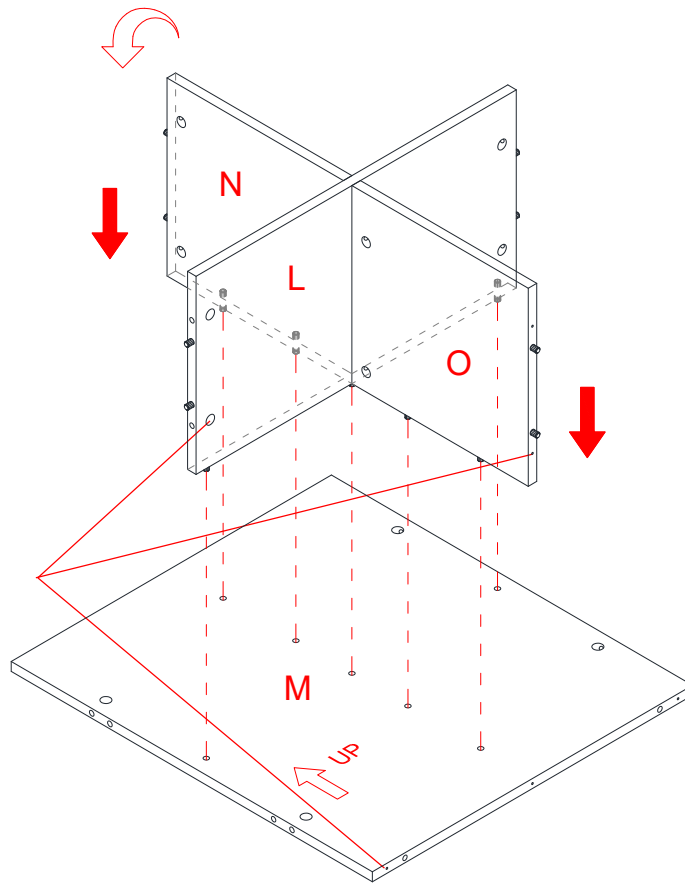

x 2

13. Align the inserted dowels of previous assembly (L, N and O) with the hole of the Bookcase Back Panels (M) and press them together.

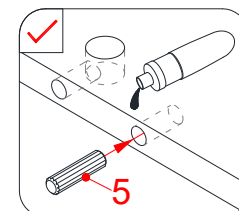
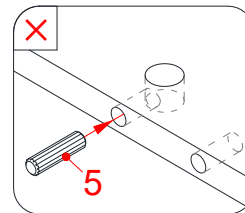
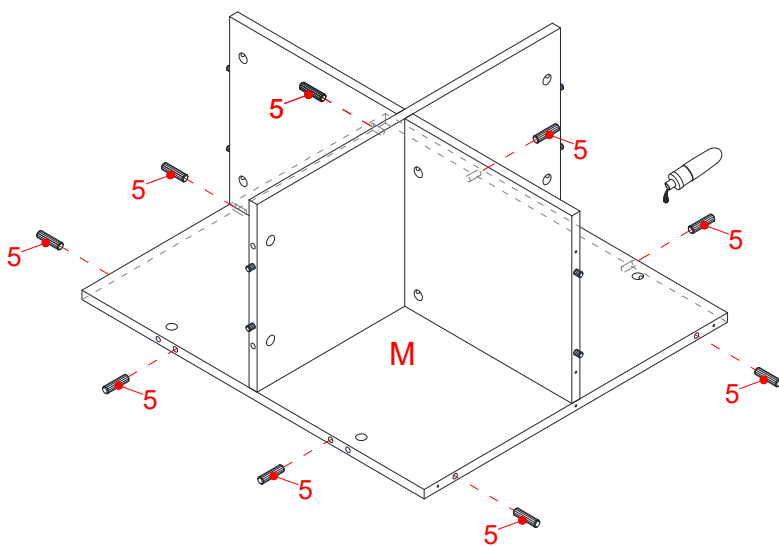

x 2

14. Glue the large Wood Dowels (5) into the inner holes on the Bookcase Back Panels (M).

## Assembly Instructions

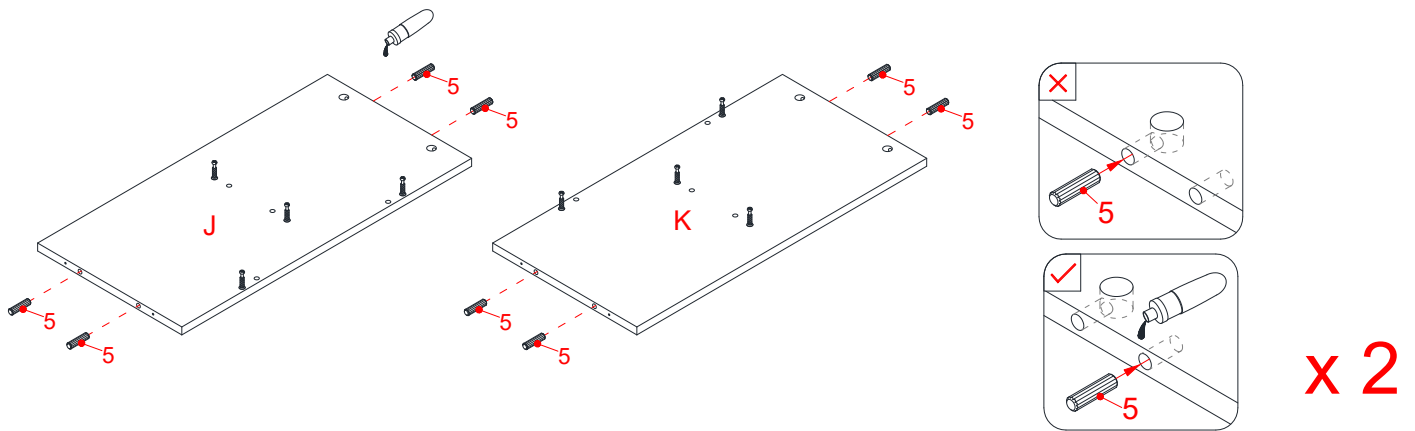

15. Glue the Large Wood Dowels (5) into the inner holes on the Bookcase Side Panels (J and K).

The cam lock holes and pilot holes point in the same direction.

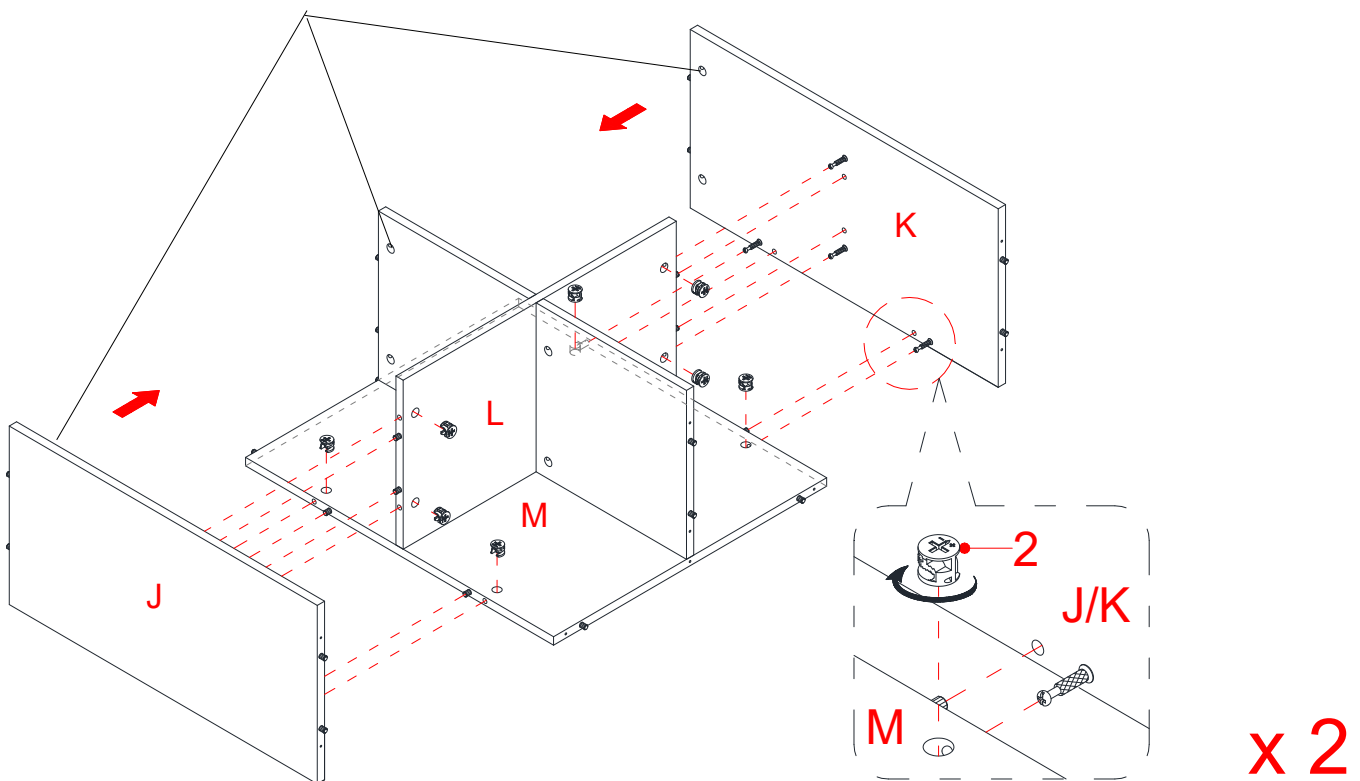

16. Attach the Bookcase Side Panels (J and K) to the Bookcase Middle shelves (L) and the Bookcase Back Panels (M) by engaging four Large Cam Locks (2) per Side Panel.

## Assembly Instructions

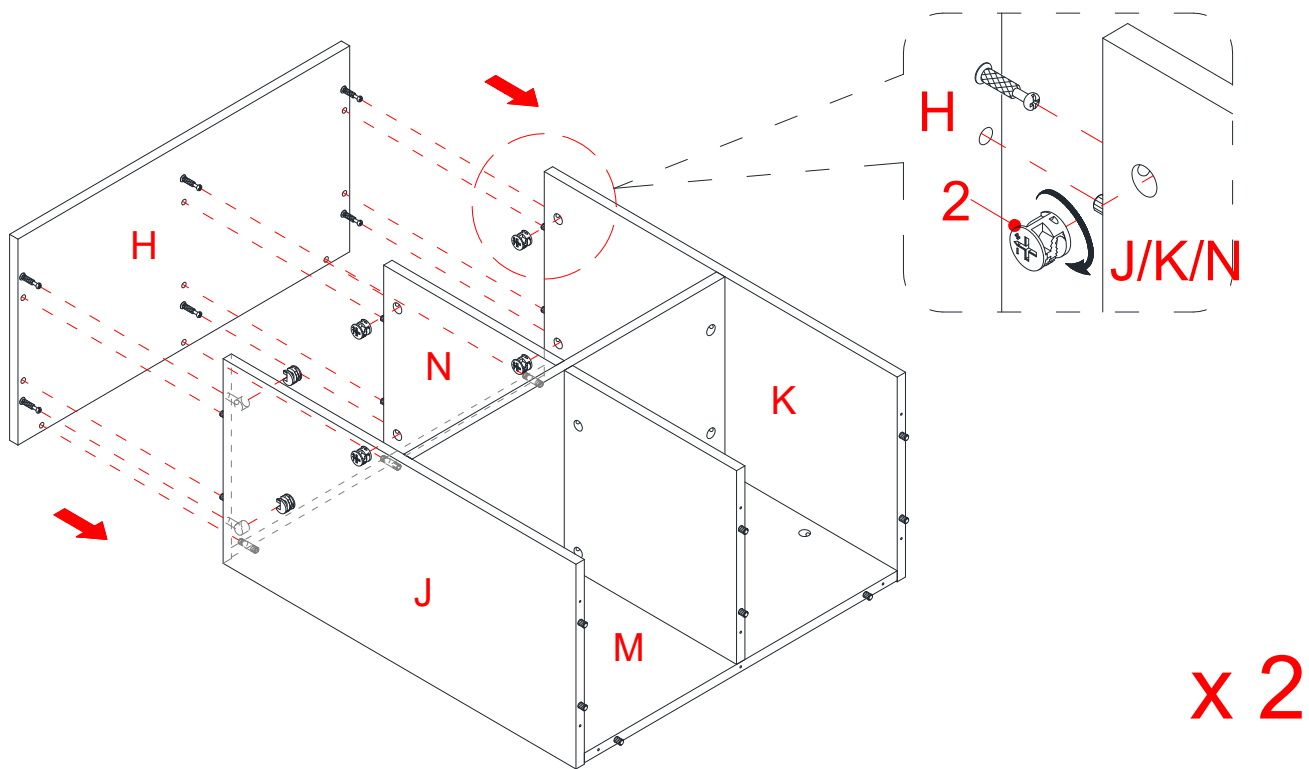

17. Attach the Bookcase Top Panels (H) to the previous assembly by engaging six Large Cam Locks (2) per top panel.

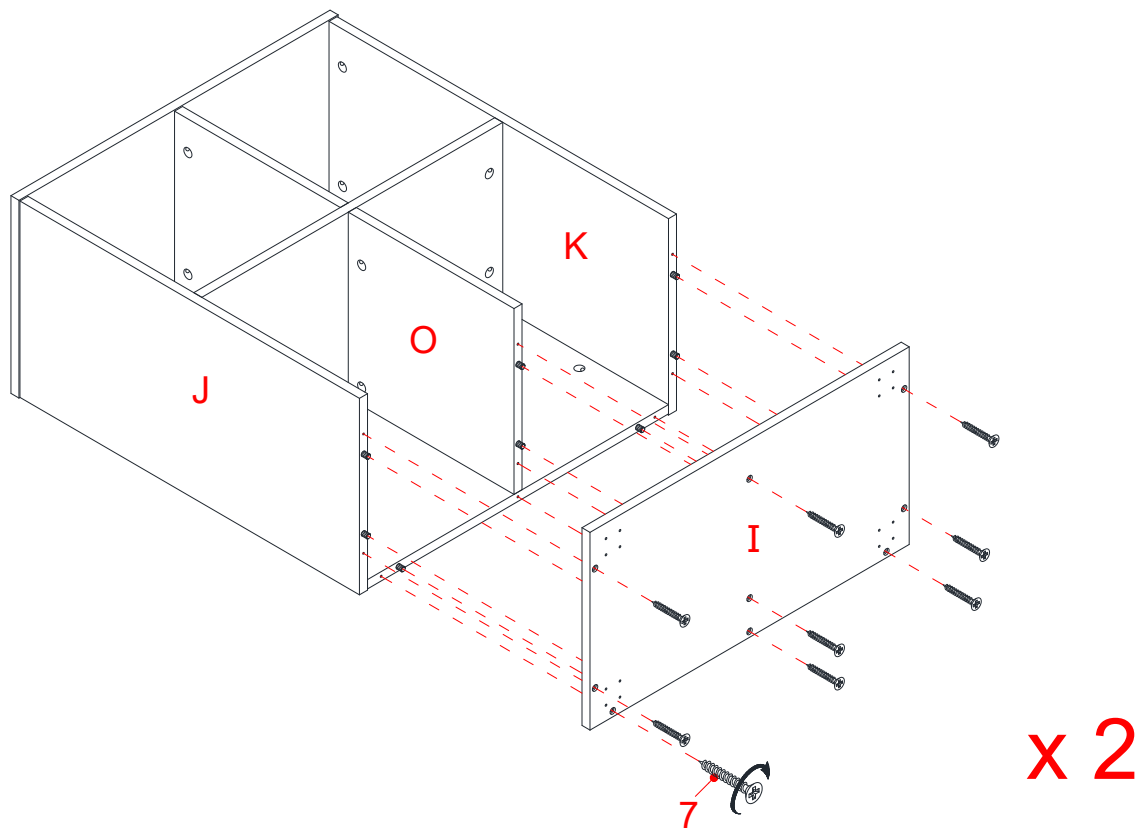

18. Using the inserted wood dowels as a guide, fasten each Bookcase Bottom Panel (I) to the assembled units with nine 32 mm Screws (7).

## Assembly Instructions

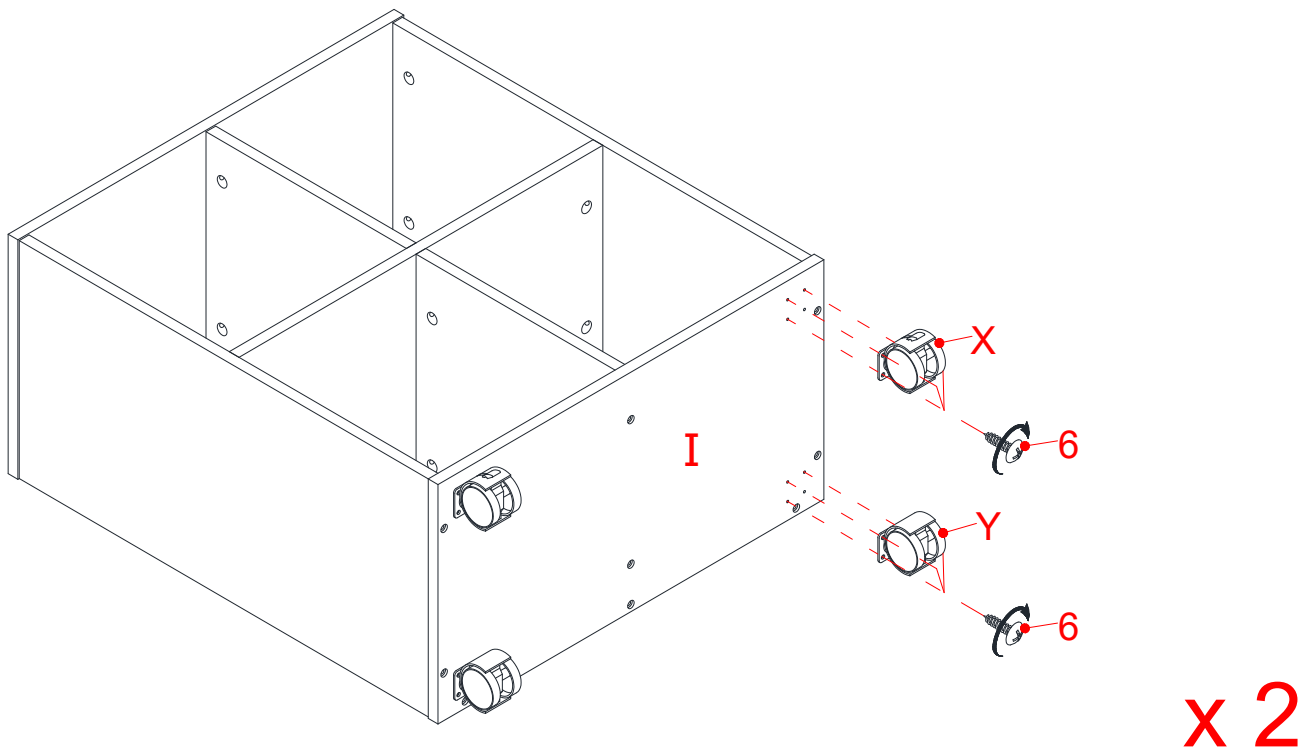

19. With the pilot holes as a guide, attach two Locking Casters (X) to the front and attach two Swivel Casters (Y) to the back of the Bookcase Bottom Panel (I), using four 15 mm Pan Head Screws (6) per caster.

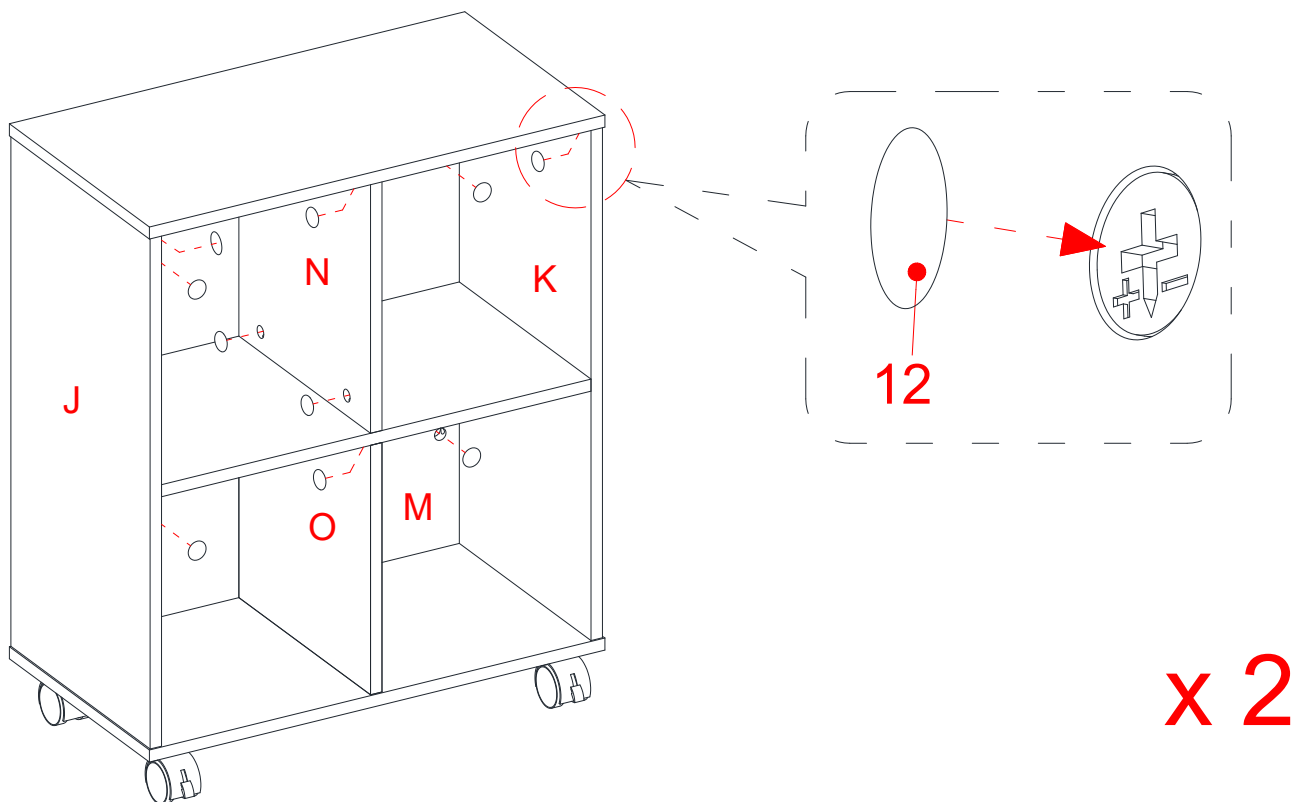

20. Ask for the assistance of another adult to stand the units upright. Put the PVC Covers (12) onto the visible Cam Locks to conceal the cams.



# Assembly Instructions

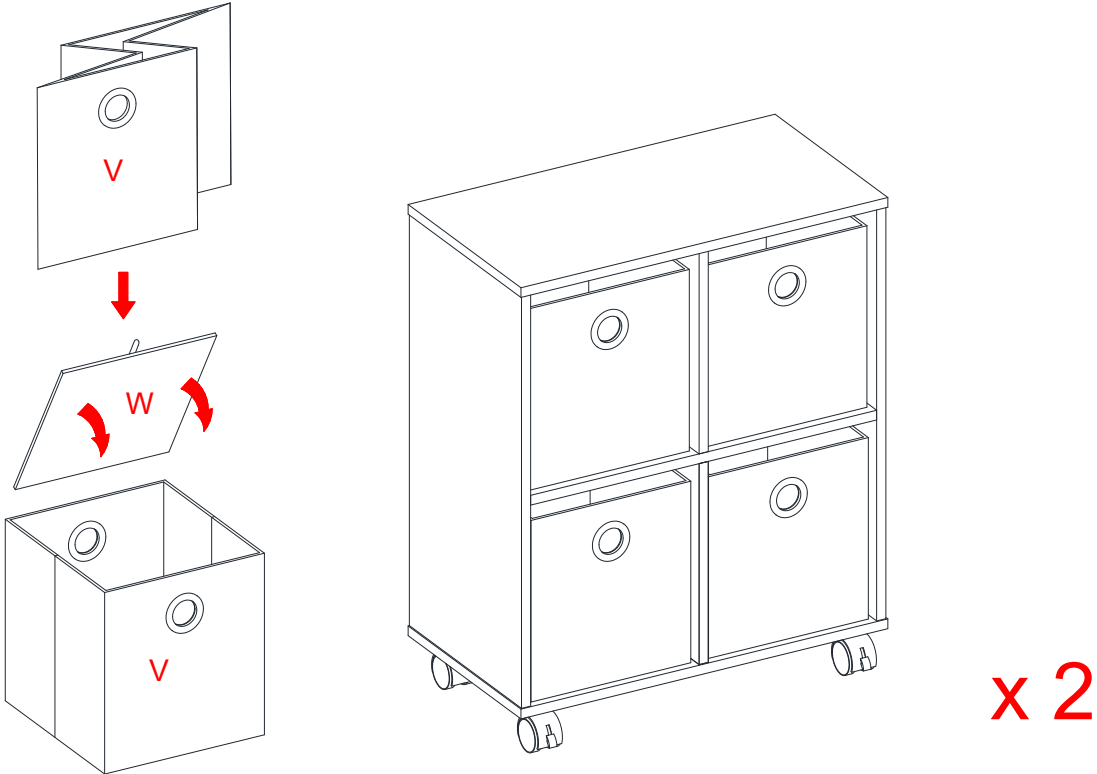

21. Unfold the Storage Baskets (V) and then place the Basket Flooring (W) inside the opened basket to ensure it remains square. Position the Storage Baskets onto the compartments.

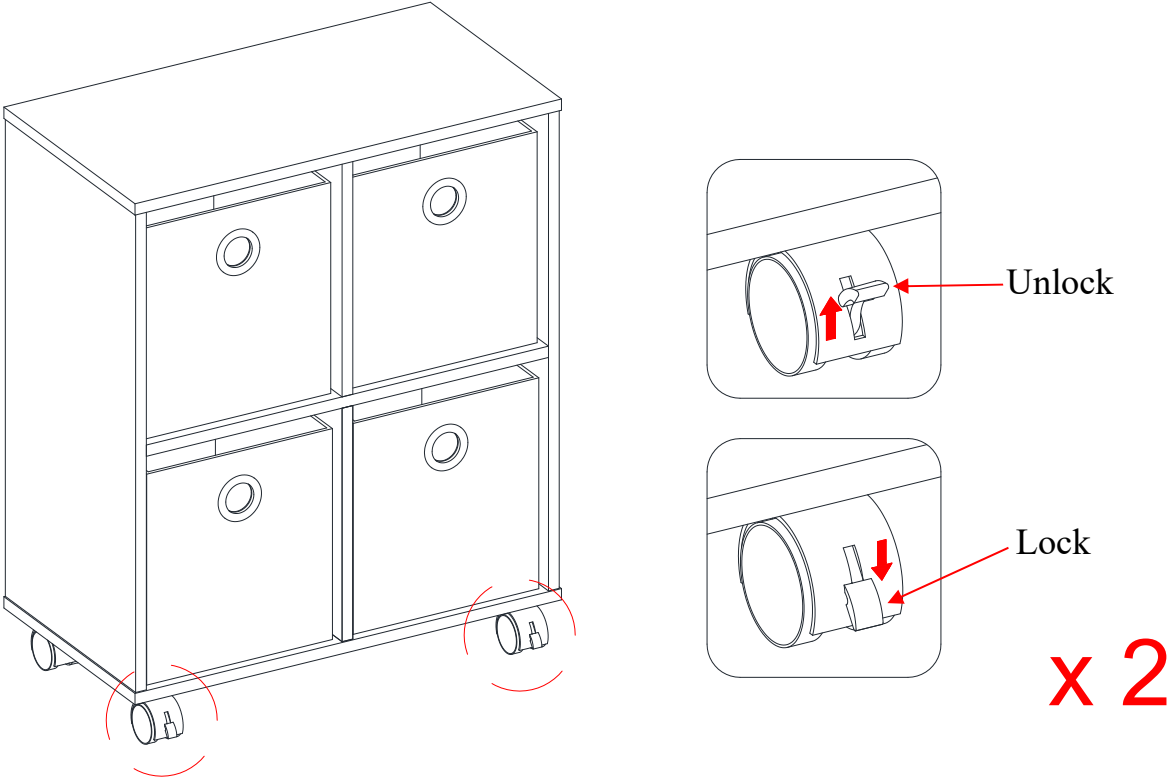

22. Adjust the brake on the two front Locking Casters (X) as shown to lock or unlock the storage unit.

## Assembly Instructions

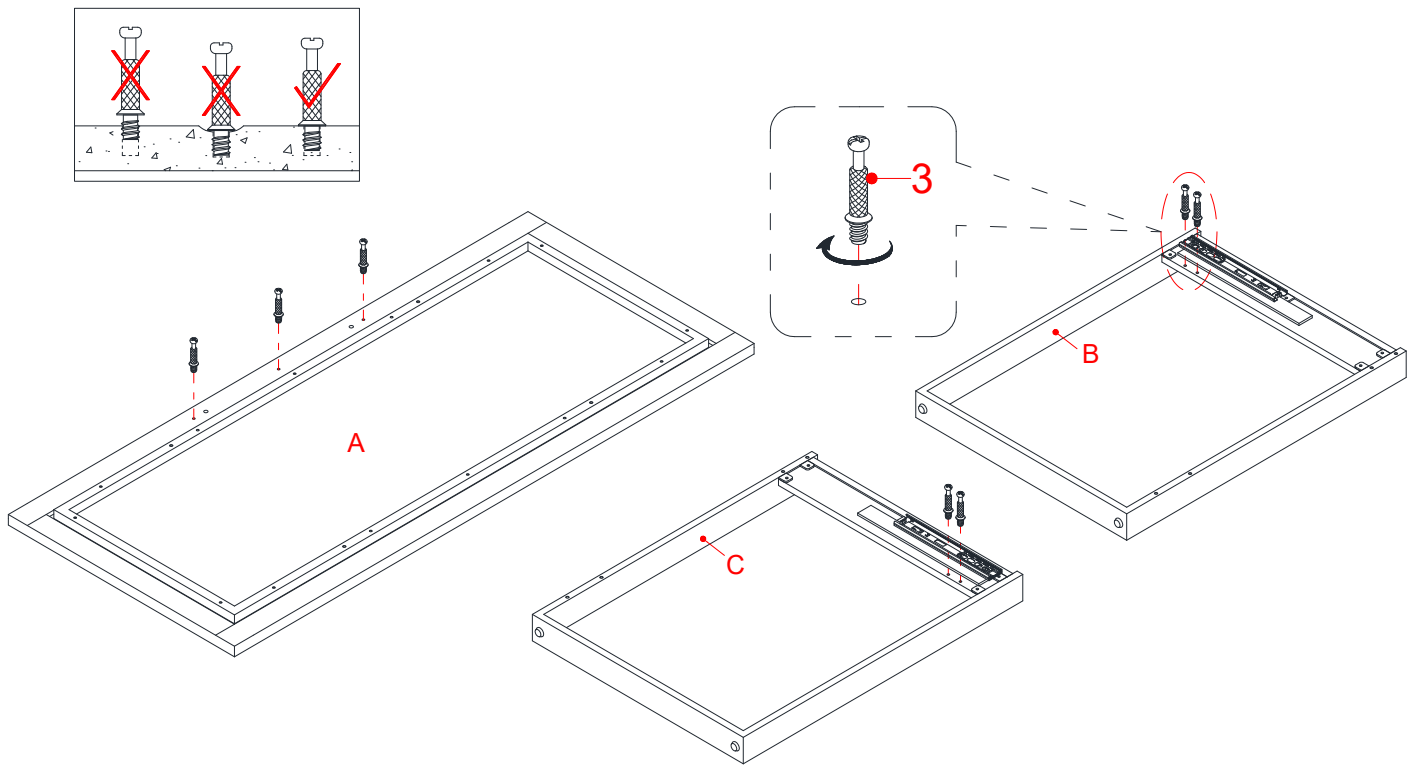

23. Securely screw the Cam Bolts (3) into the designated small holes on the Desk Top (A) and Side Frames (B and C) as shown with a Phillips screwdriver.

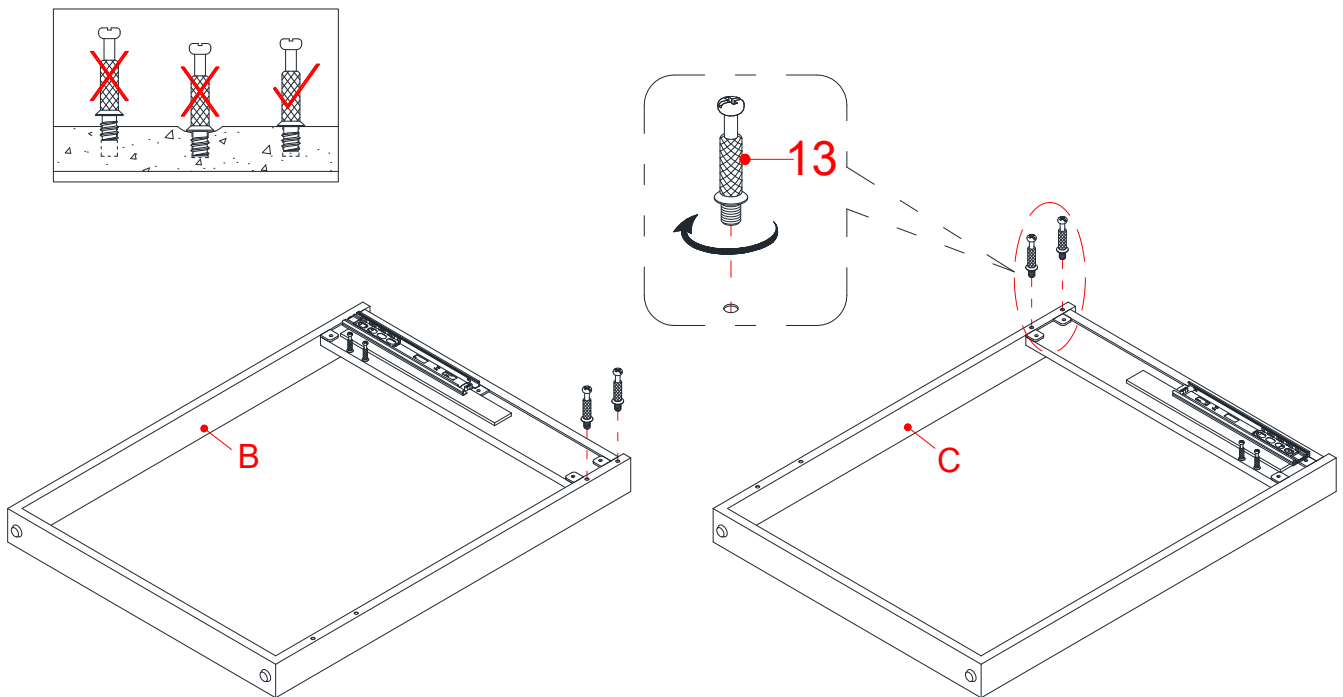

24. Securely screw the Cam Bolts (13) into the designated small holes on the Side Frames (B and C) as shown with a Phillips screwdriver.

## Assembly Instructions

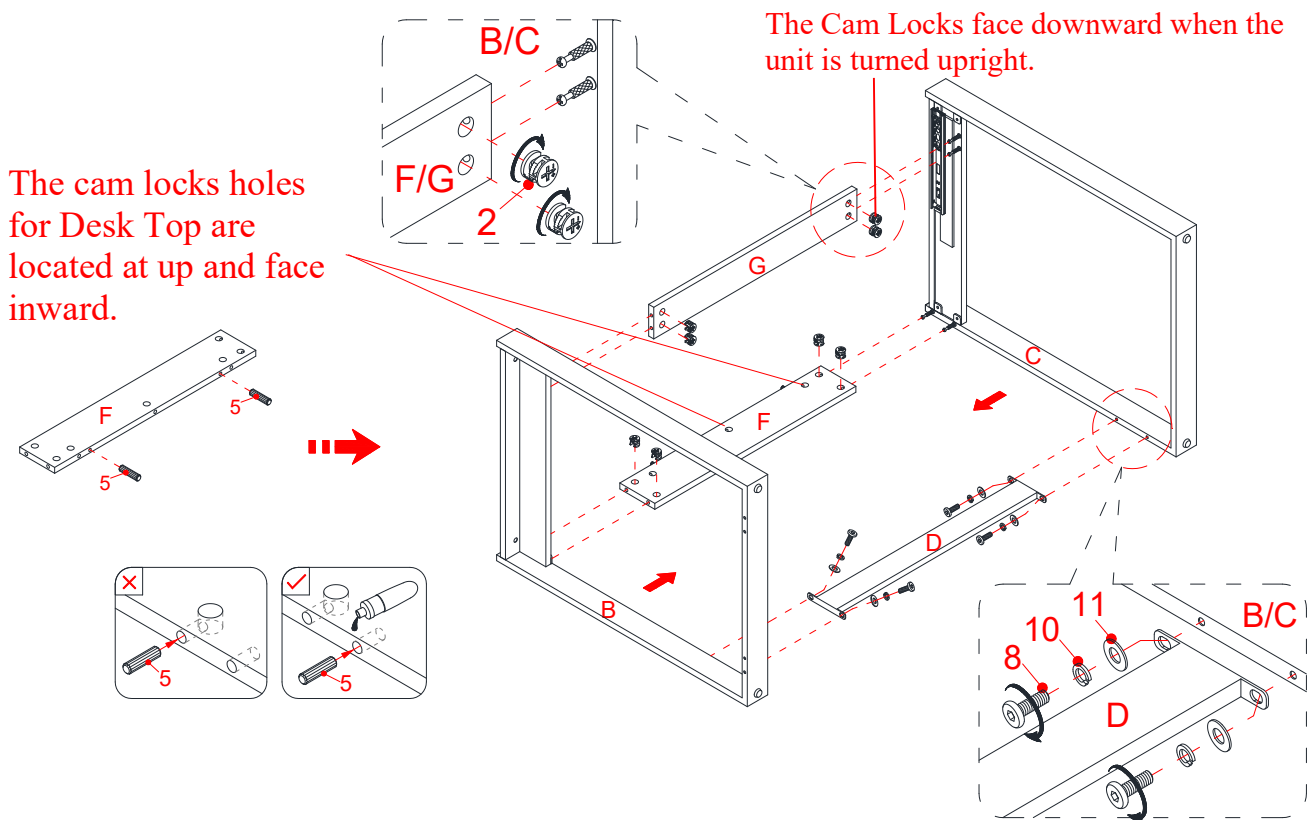

25. Glue two large Wood Dowels (5) into the pre-drilled holes on the top edge of the Upper Back Stretcher (F).
26. Attach the Upper Stretchers (F and G) between the Side Frames (B and C) by engaging eight Large Cam Locks (2).
27. Attach Lower Stretcher (D) between the Side Frames (B and C) using four 15 mm Bolts (8) and four Washers (10 and 11).

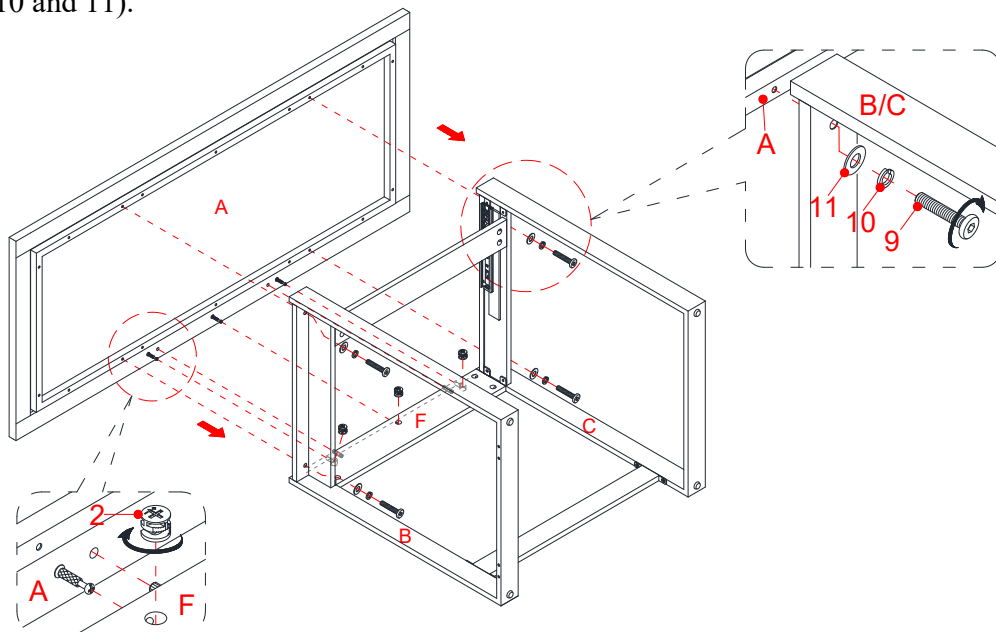

28. Align and attach the Desk Top (A) to the Upper Back Stretcher (F) by engaging three Large Cam Locks (2).
29. Secure the Desk Top (A) to the Side Frames (B and C) with four 32 mm Bolts (4) and four Washers (10 and 11).

## Assembly Instructions

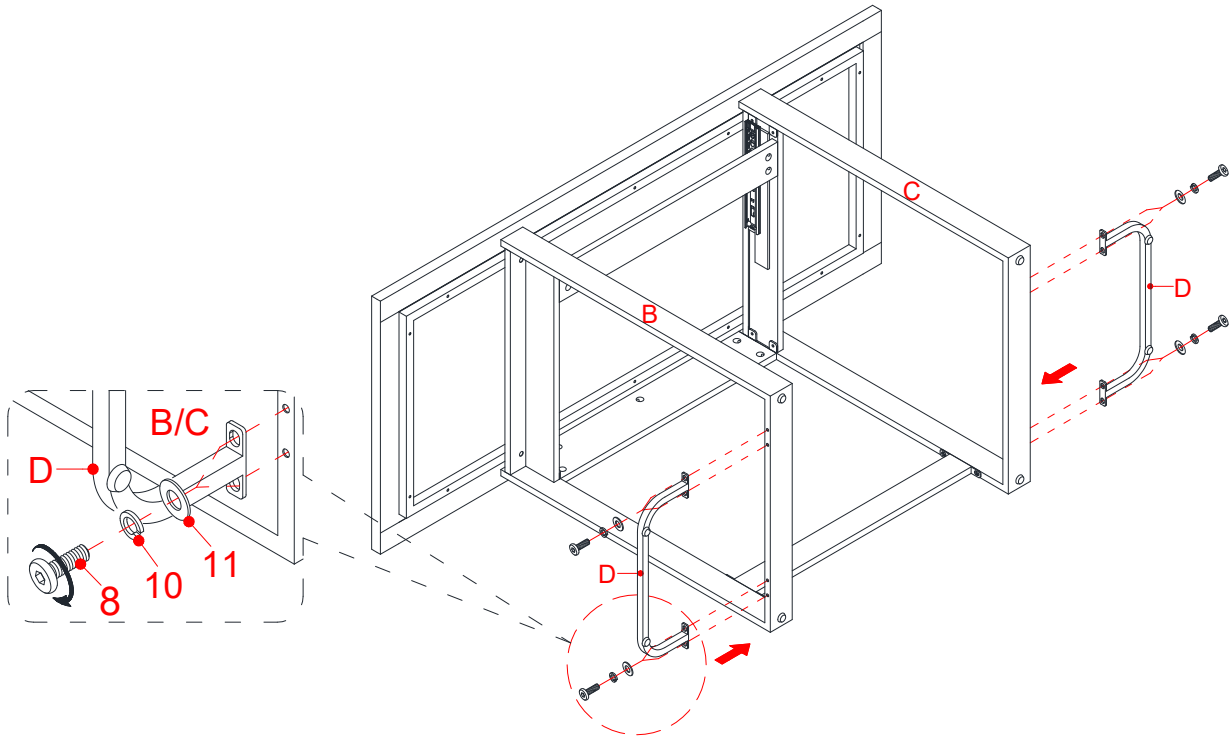

30. Attach two Stabilizers (E) to the Side Frames (B and C) using eight 15 mm Bolts (8) and eight Washers (10 and 11).

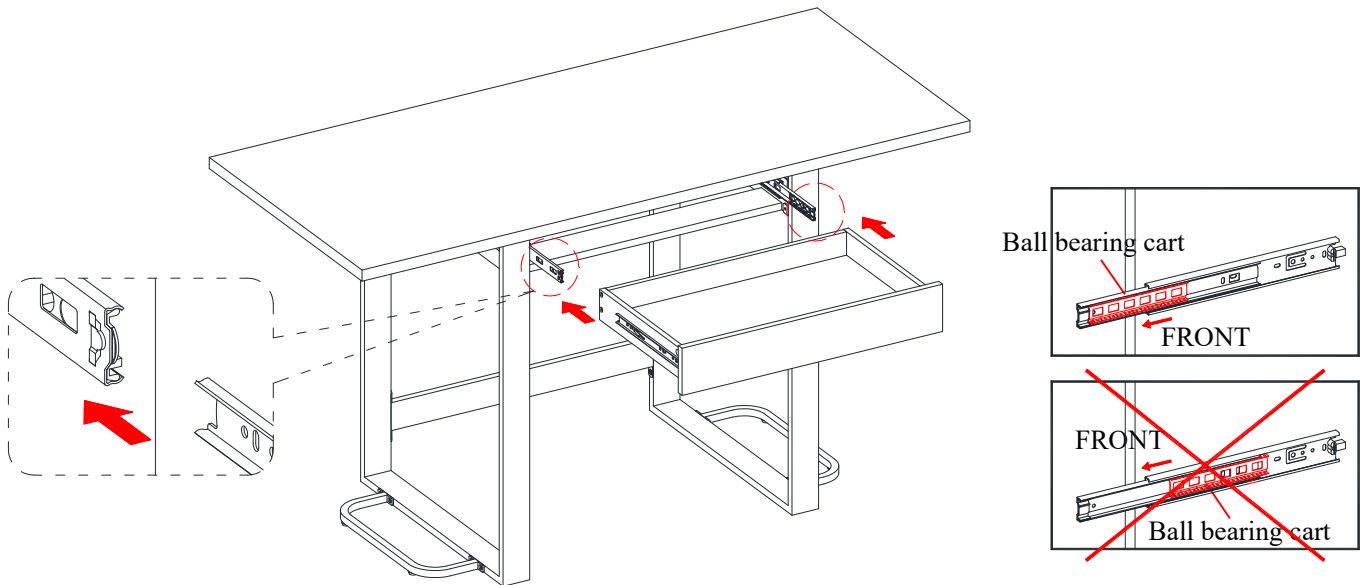

31. Ask for assistance to stand the unit upright and position at the desired location.
32. Insert the assembled drawer into the frame. Extend the Ball Bearing Slide Tracks on the Side Frames (B and C) all the way forward (including ball bearing cart). Then align the slide runners on the drawer side panels with the slide tracks and push the drawer carefully inside until it stops.

**NOTE:** If the drawer does not go in smoothly, please take it out and repeat the step. If you need to remove the drawer, please pull the drawer all the way out, then simultaneously push the plastic release lever of the ball bearing slides up on one side and down on the other side, and then pull it completely out.

## Assembly Instructions

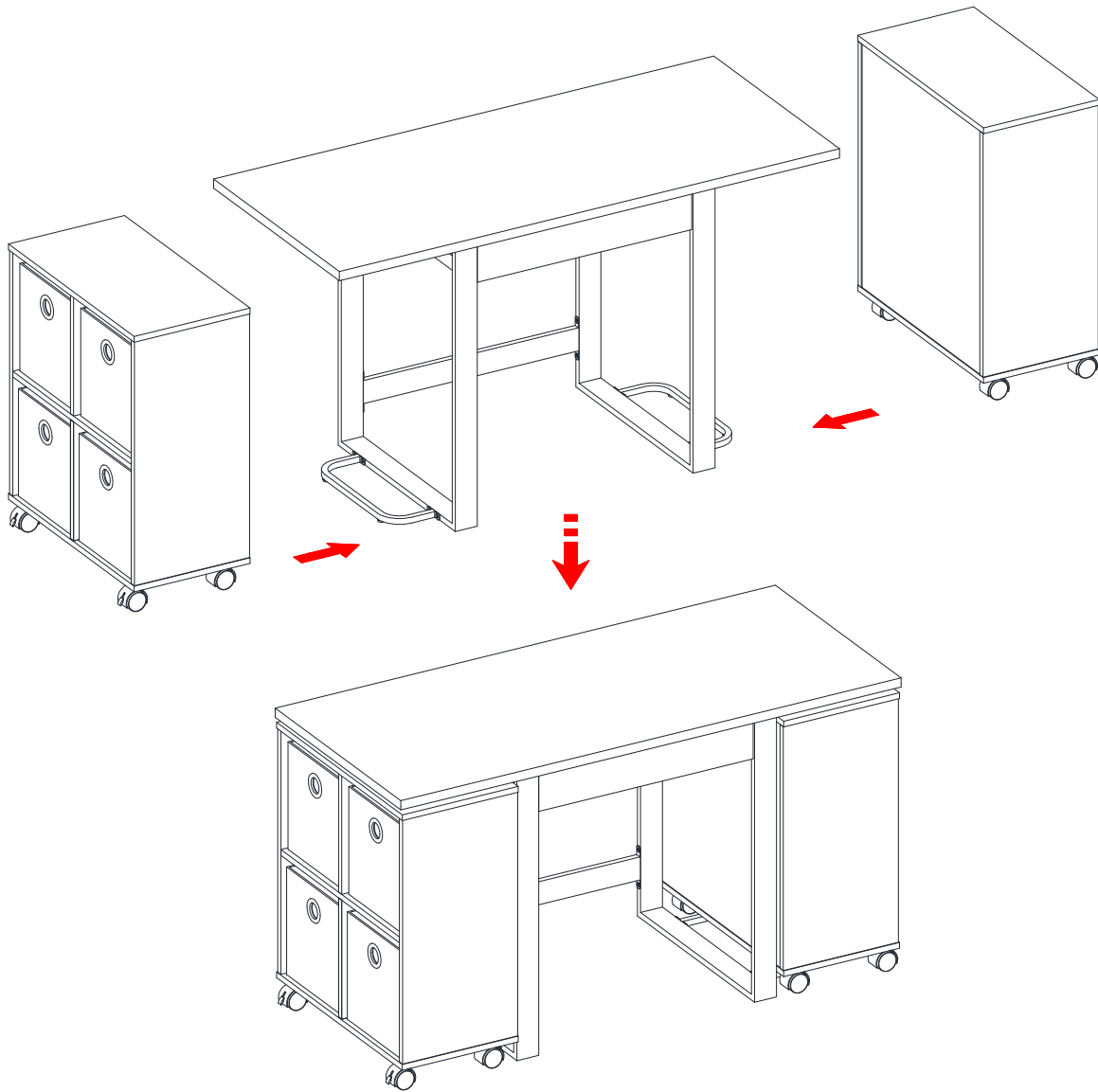

33. Combine the two bookcases with the assembly desk as shown.

## Assembly Instructions

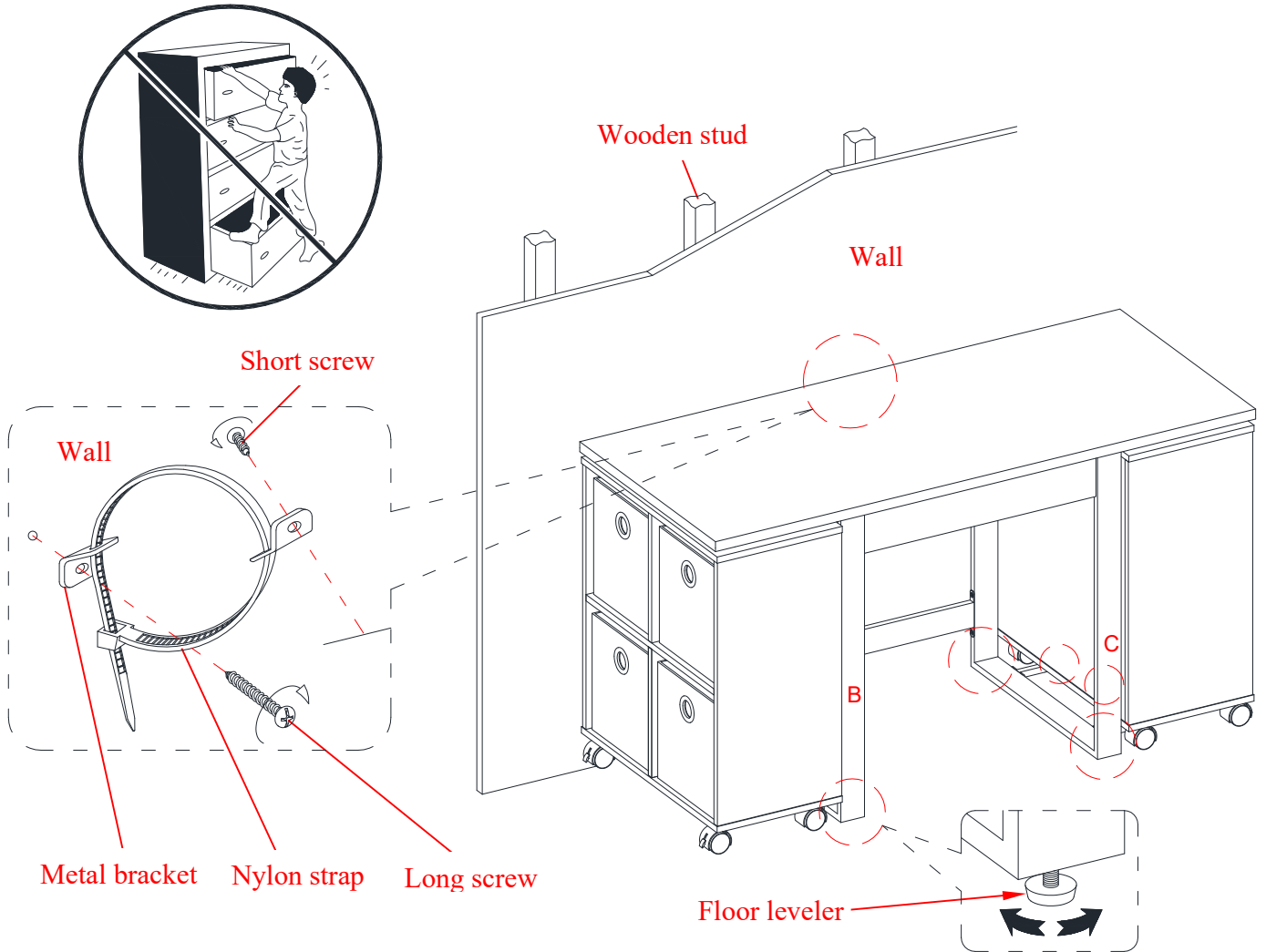

**Tools required (not provided):** Phillips screwdriver, stud finder, tape measure, pencil, power drill and 1/8" drill bit.

34. Position the unit at the desired location against a wall. If necessary, adjust the Floor Levelers at the bottom of the Side Frames (B and C) to level the unit.
35. Now, follow the instructions printed on the plastic bag containing the Tipping Restraint Hardware to attach the tip-over restraints to the unit and the wall.

**NOTE:** The tipping restraint hardware included is for wooden stud wall construction. It must be attached to a wall stud. Depending upon your wall construction, different anchor hardware maybe required. Please contact your local hardware store for assistance. Young children can be seriously injured by tipping furniture. You must install the tipping restraint hardware with the unit to prevent the unit from tipping, causing any accidents or damage. The tipping restraints are intended only as a deterrent, they are not a substitute for proper adult supervision. The tipping restraints are not earthquake restraints. If you wish to add the extra security of earthquake restraints, they must be purchased and installed separately.

36. The unit is now ready for use.

## Care and Maintenance

- Use a soft, clean cloth that will not scratch the surface when dusting.
- Gently rub the surface with a soft dry cloth, soft damp cloth, or soft damp cloth with neutral detergent, and then dry it well.
- Strong Alkaline detergents or acidic detergents are not recommended to use.
- Sponges containing abrasive agents or fibers are not recommended to use.
- Use of furniture polish is not necessary. Should you choose to use polish, test first in an inconspicuous area.
- Using solvents of any kind on your furniture may damage the finish.
- Never use water to clean your furniture as it may cause damage to the finish.
- Always use coasters under beverage glasses and flowerpots.
- Liquid spills should be removed immediately. Using a soft, clean cloth, blot the spill gently. Avoid rubbing.
- Always use protective pads under hot dishes and plates. Heat can cause chemical changes that may create spotting within the furniture finish.
- In the event that your furniture is stained or otherwise damaged during use, we recommend that you call a professional to repair your furniture.
- Check bolts/screws periodically and tighten them if necessary.

## Further advice about wood furniture care

It is best to keep your furniture in a climate-controlled environment. Extreme temperature and humidity changes can cause fading, warping, shrinking and splitting of wood. It is advised to keep furniture away from direct sunlight as sun may damage the finish.

Proper care and cleaning at home will extend the life of your purchase. Following these important and helpful tips will enhance your furniture as it ages.

We hope you enjoy your purchase for many years.  
Thank you for your purchase!

## QUALITY GUARANTEE

We are confident that you will be delighted with your Whalen Furniture purchase.

Should this product be defective in workmanship or materials or fail under normal use, we will repair or replace it for up to one (1) year from date of purchase. Every Whalen Furniture product is designed to meet your highest expectations. We guarantee that you will immediately see the value of our fine furniture.

This warranty gives you specific legal rights and you may also have other rights which vary from State to State or province to province.

Whalen Furniture Manufacturing  
1578 Air Wing Road, San Diego CA, 92154, USA  
Customer Service: 866-942-5362  
8:30 a.m. - 4:30 p.m., PST, Monday to Friday  
[www.whalenfurniture.com](http://www.whalenfurniture.com)