



LOT NUMBER: \_\_\_\_\_  
DATE PURCHASED: \_\_/\_\_/\_\_

# Abington 2 Tone Desk

## Model # SPUS-ABTD



**ADULT ASSEMBLY REQUIRED DUE TO THE PRESENCE OF SMALL PARTS, SHARP POINTS, SHARP EDGES AS RECEIVED**

If you have any questions regarding assembly or if parts are missing, DO NOT return this item to the store where it was purchased. Please call our toll-free customer service number and have your instructions and parts list ready to provide the model name, part name or factory number:

**1-866-942-5362**

Pacific Standard Time: 8:30 a.m. - 4:30 p.m., Monday - Friday  
Or visit our web site 24 hours a day, 7 days a week for product assistance at

**[www.whalenfurniture.com](http://www.whalenfurniture.com)**

Or e-mail your request to **[parts@whalenfurniture.com](mailto:parts@whalenfurniture.com)**

**THIS INSTRUCTION BOOKLET CONTAINS IMPORTANT SAFETY INFORMATION.  
PLEASE READ AND KEEP FOR FUTURE REFERENCE.**

Date 2018-09-18

Rev. 0001-A

## MAXIMUM RECOMMENDED WEIGHT LOADS

MANUFACTURER: Whalen Furniture Manufacturing  
CATALOG: Abington 2 Tone Desk  
MODEL #: SPUS-ABTD  
MADE IN CHINA

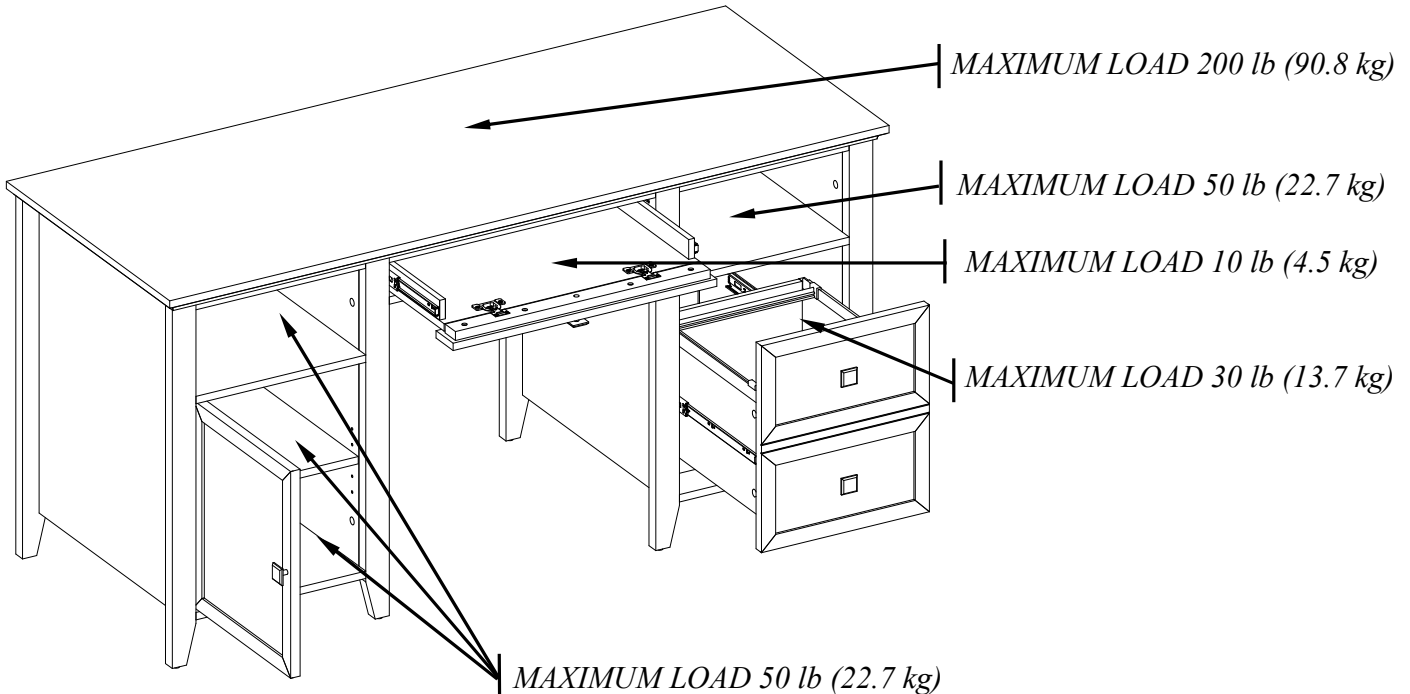

**⚠ WARNING** THIS UNIT IS INTENDED ONLY FOR USE WITHIN THE MAXIMUM WEIGHTS INDICATED. USE WITH LOAD HEAVIER THAN THE MAXIMUM WEIGHTS INDICATED MAY RESULT IN INSTABILITY, CAUSING POSSIBLE INJURY.

### SPECIAL NOTE

Please read the instruction sheets completely before assembly. Examine all packaging material before discarding carton. Remove any remaining staples from the carton before discarding. Remove all parts from carton and separate into groups as indicated on part list. Please ensure all parts are included prior to assembly. Use of power tools to complete assembly is not recommended.

## IMPORTANT

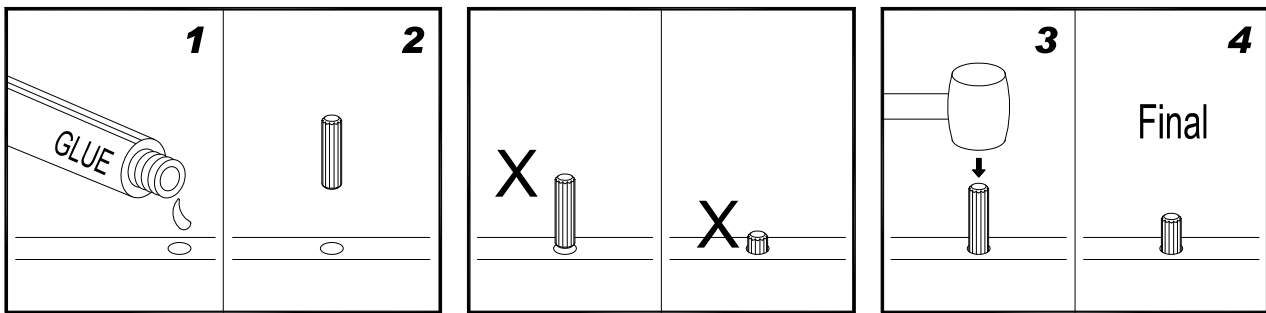

**Before you begin:** Open, identify and count all parts prior to assembly. Lay out parts on a flat and non-abrasive surface. You will need the parts identified on page 4 and 5 of this instruction manual.

**NOTE:** IT IS VERY IMPORTANT TO USE GLUE WITH DOWELS. EXCESS GLUE CAN BE WIPED OFF WITH DAMP CLOTH.

Insert the Dowel at least half way by tapping lightly with a rubber mallet, IF NECESSARY.

## CAM LOCK SYSTEM OPERATION

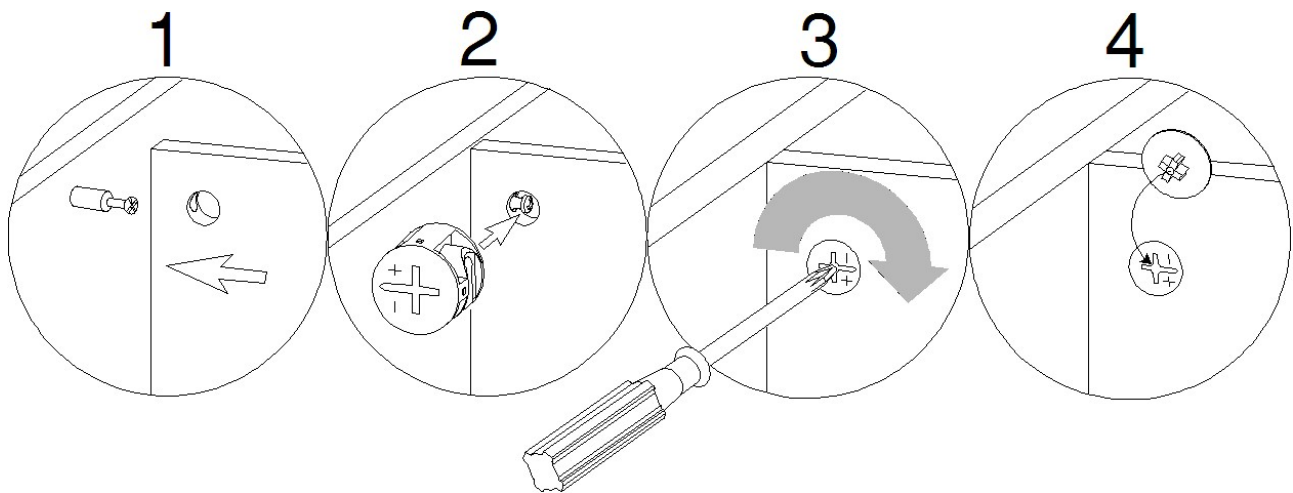

## HOW THE KNOCK DOWN (KD) ASSEMBLY SYSTEM WORKS

1. Screw the Cam Bolt into the threaded inserts on the panel. Connect both panels together; making sure Cam Bolt goes into the pre-drilled hole on the end of panel for Cam Lock.
2. Insert the Cam Lock into the pre-drilled large hole on the panel. Make sure the arrow on the face of Cam Lock faces out and points towards Cam Bolt.
3. Take a Phillips screwdriver and rotate the Cam Lock clockwise to lock the Cam Bolt in place.
4. Plug the Cam Lock Cover into the cross slot of the Cam Lock to conceal the Cam.

You are now ready to assemble the KD unit.

## Parts and Hardware List

Please read completely through the instructions and verify that all listed parts and hardware are present before beginning assembly.

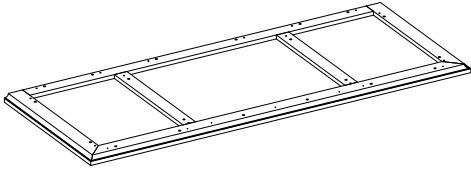

A- Desk Top (Qty. 1)

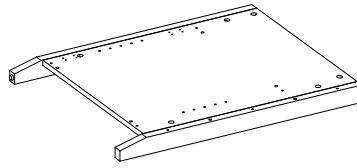

B- Left Side Panel (Qty. 1)

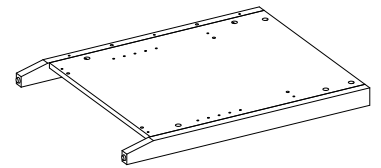

C- Left Partition Panel (Qty. 1)

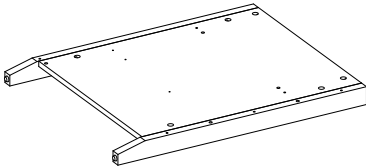

D- Right Partition Panel (Qty. 1)

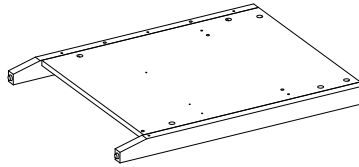

E- Right Side Panel (Qty. 1)

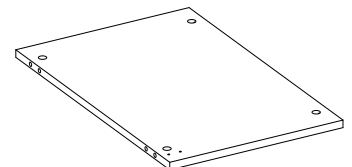

F- Fixed Shelf (Qty. 3)

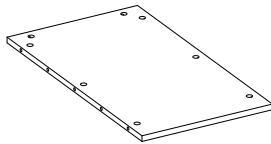

G- Side Back Panel (Qty. 2)

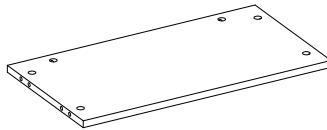

H- Middle Back Panel (Qty. 1)

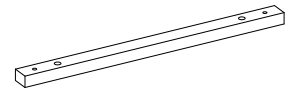

I- Short Top Stretcher (Qty. 2)

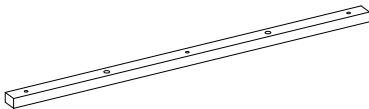

J- Middle Top Stretcher (Qty. 1)

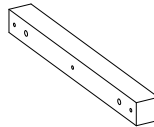

K- Slider Support (Qty. 2)

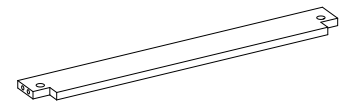

L- Middle Stretcher (Qty. 1)

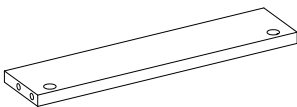

M- Side Stretcher (Qty. 1)

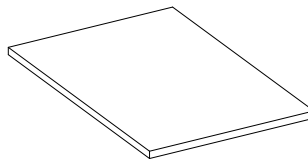

N- Adjustable Shelf (Qty. 1)

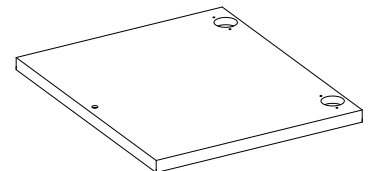

O- Door Panel (Qty. 1)

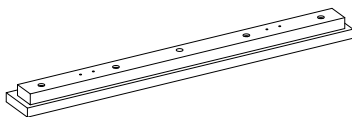

P1- Middle Drawer Front  
(Qty. 1)

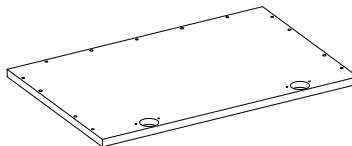

P2- Middle Drawer Bottom Panel  
(Qty. 1)

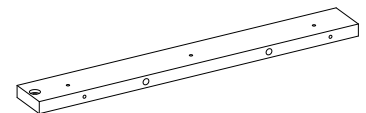

P3- Middle Drawer Left Side  
(Qty. 1)

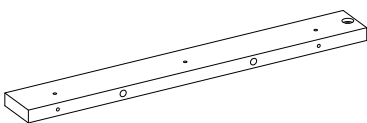

P4- Middle Drawer Right Side  
(Qty. 1)

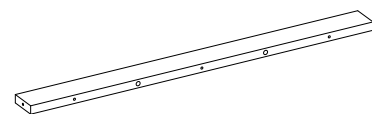

P5- Middle Drawer Back Panel  
(Qty. 1)

## Parts and Hardware List

Please read completely through the instructions and verify that all listed parts and hardware are present before beginning assembly.

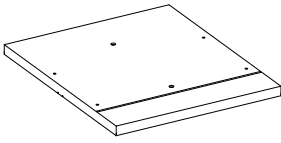

Q1- File Drawer Front (Qty. 1)

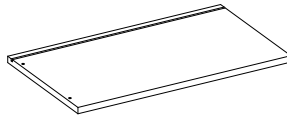

Q2- File Drawer Left Side (Qty. 1)

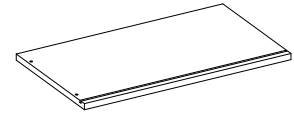

Q3- File Drawer Right Side (Qty. 1)

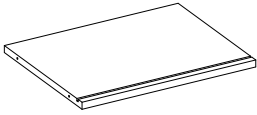

Q4- File Drawer Back Panel (Qty. 1)

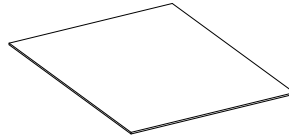

Q5- File Drawer Bottom Panel (Qty. 1)

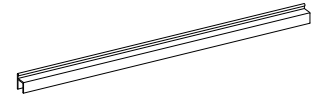

R- Guide Rail (Qty. 2)

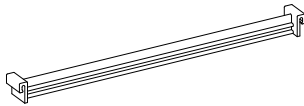

S- File Hanger (Qty. 2)

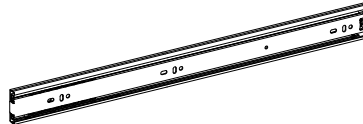

T- 16" Ball Bearing Slides (Qty. 2)

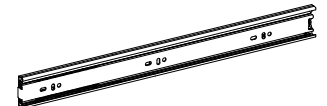

U- 14" Ball Bearing Slides (Qty. 2)



(1) Small Cam Lock (Qty. 4+1 extra)



(2) Large Cam Lock (Qty. 46+2 extra)

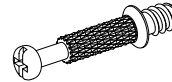

(3) Cam Bolt (Qty. 50+2 extra)

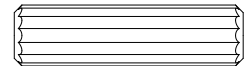

(4) M8 x 30 mm Wood Dowel (Qty. 52+2 extra)

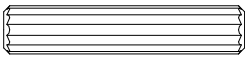

(5) M6 x 30 mm Wood Dowel (Qty. 6+1 extra)

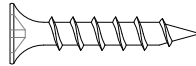

(6) M4 x 25 mm Screw (Qty. 7+1 extra)

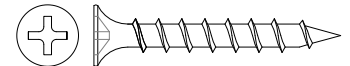

(7) M4 x 32 mm Screw (Qty. 13+1 extra)

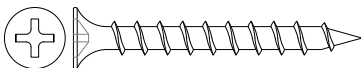

(8) M4 x 38 mm Screw (Qty. 6+1 extra)



(9) M3.5 x 12 mm Screw (Qty. 26+1 extra)

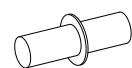

(10) Shelf Pin (Qty. 4+1 extra)



(11) Handle (Qty. 4)

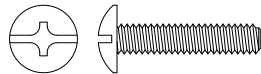

(12) Handle Bolt (Qty. 4)

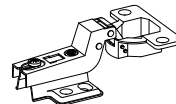

(13) Door Hinge (Qty. 2)

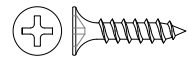

(14) M3.5 x 15 mm Zinc Screw (Qty. 20+1 extra)

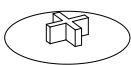

(15) Cam Lock Cover (Qty. 34+1 extra)

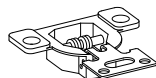

(16) Middle Drawer Front Hinge (Qty. 2)



(17) Door Stopper (Qty. 1)

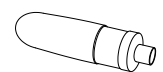

Glue (Qty. 1)

**Tools required: Phillips screwdriver and hammer (not provided).**

## Middle Drawer Assembling

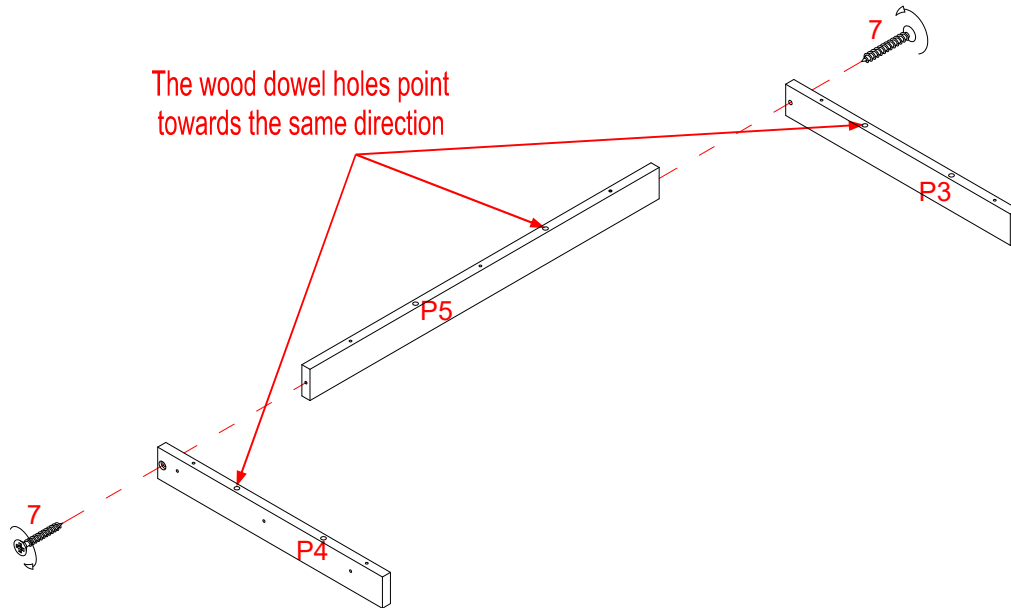

1. Unpack the unit and confirm that you have all the hardware and required parts. Assemble the unit on a carpeted floor or the empty carton to avoid any scratch.
2. Fasten the Middle Drawer Back Panel (P5) between the Middle Drawer Side Panels (P3 and P4) with two 32 mm Screws (7).

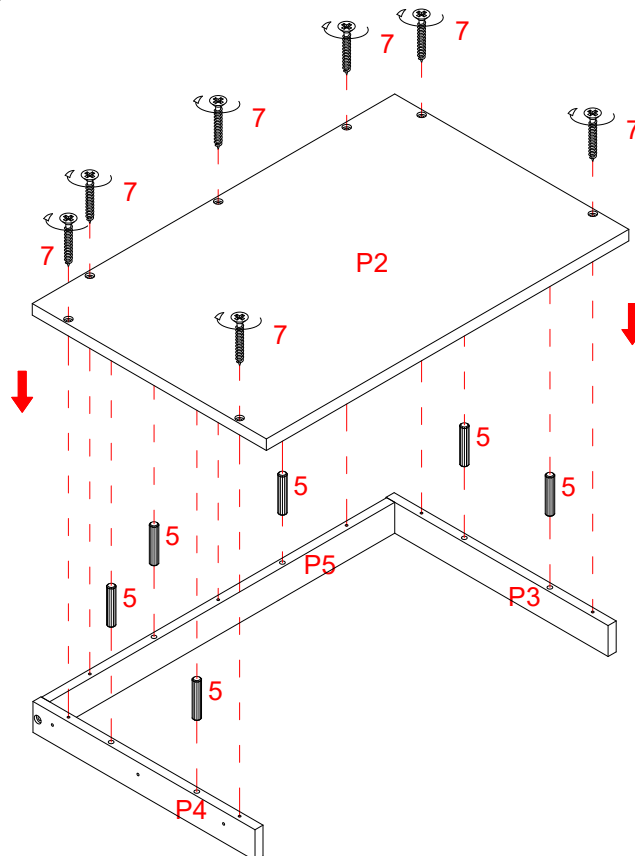

3. Attach the Middle Drawer Bottom Panel (P2) to the Middle Drawer Side Panels (P3 and P4) and Back Panel (P5) with six 30 mm Wood Dowels (5) and seven 32 mm Screws (7). Make sure that you use a small amount of glue with both ends of all dowels.

**NOTE:** It is very important to use a small amount of glue on both ends of dowels.



## Drawer Assembling

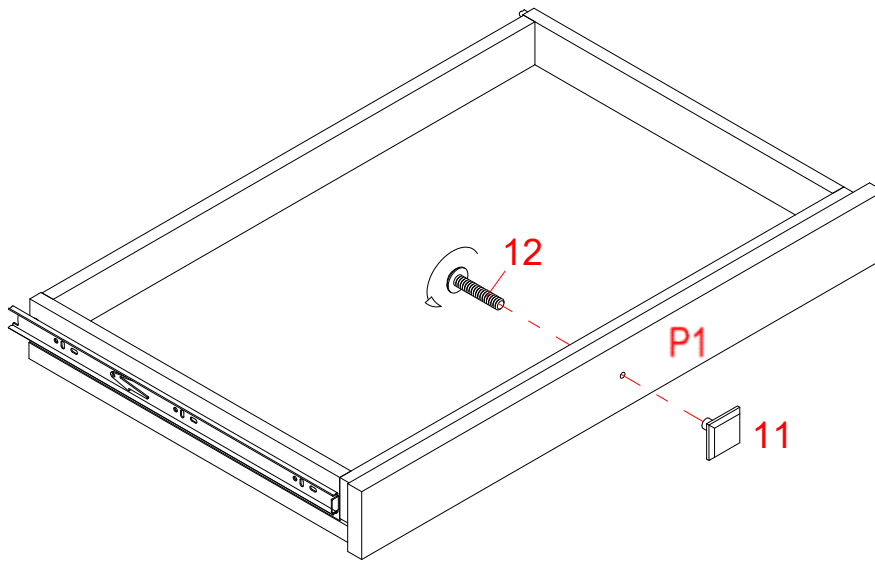

7. Attach one Handle (11) to the outside of Middle Drawer Front (P1) with the provided Handle Bolt (12).

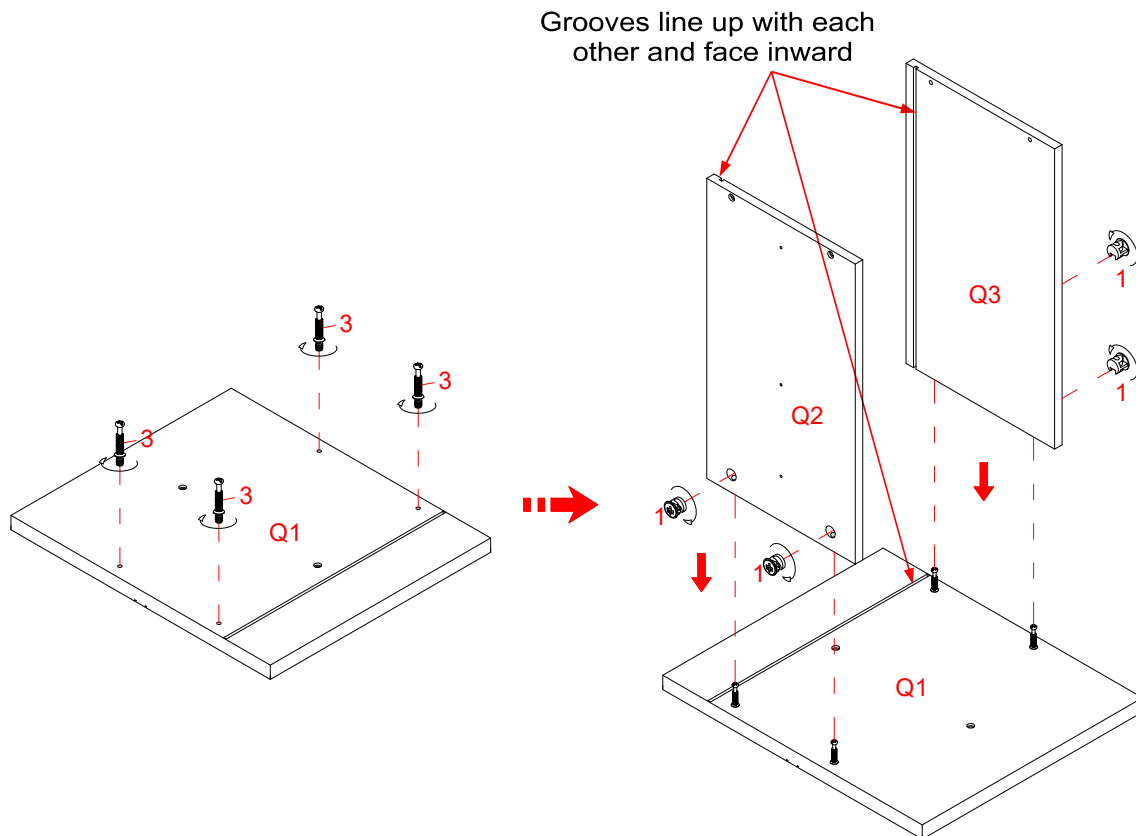

8. Securely screw four Cam Bolts (3) into the designated small holes on the File Drawer Front (Q1).
9. Attach the Middle Drawer Left and Right Sides (Q2 and Q3) to the Middle Drawer Front (Q1) with four Small Cam Locks (1) (Refer to page 3 on Cam Lock system operation supplement).



## File Drawer Assembling

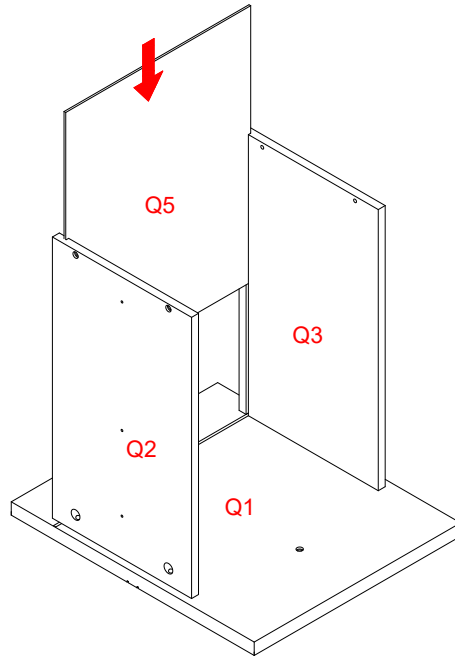

10. Slide the File Drawer Bottom Panel (Q5) all the way into the grooves with finished surface up.

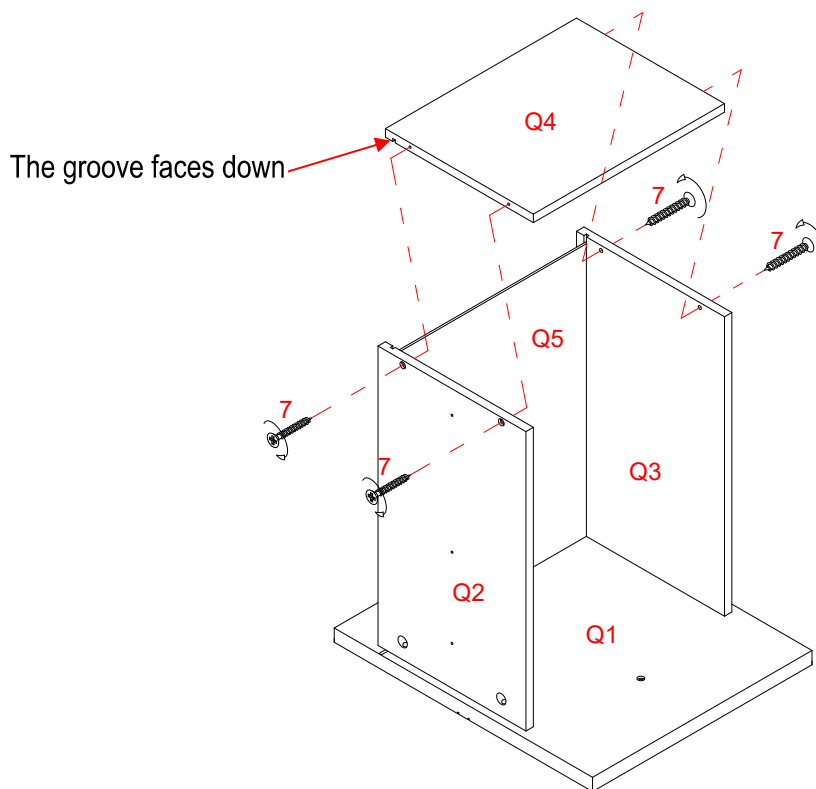

11. Fasten the File Drawer Back Panel (Q4) to the Drawer Side Panels (Q2 and Q3) with four 32 mm Screws (7). Make sure that Drawer Bottom Panel (Q5) fits securely into the groove of the Drawer Back Panel (Q4).

## File Drawer Assembling

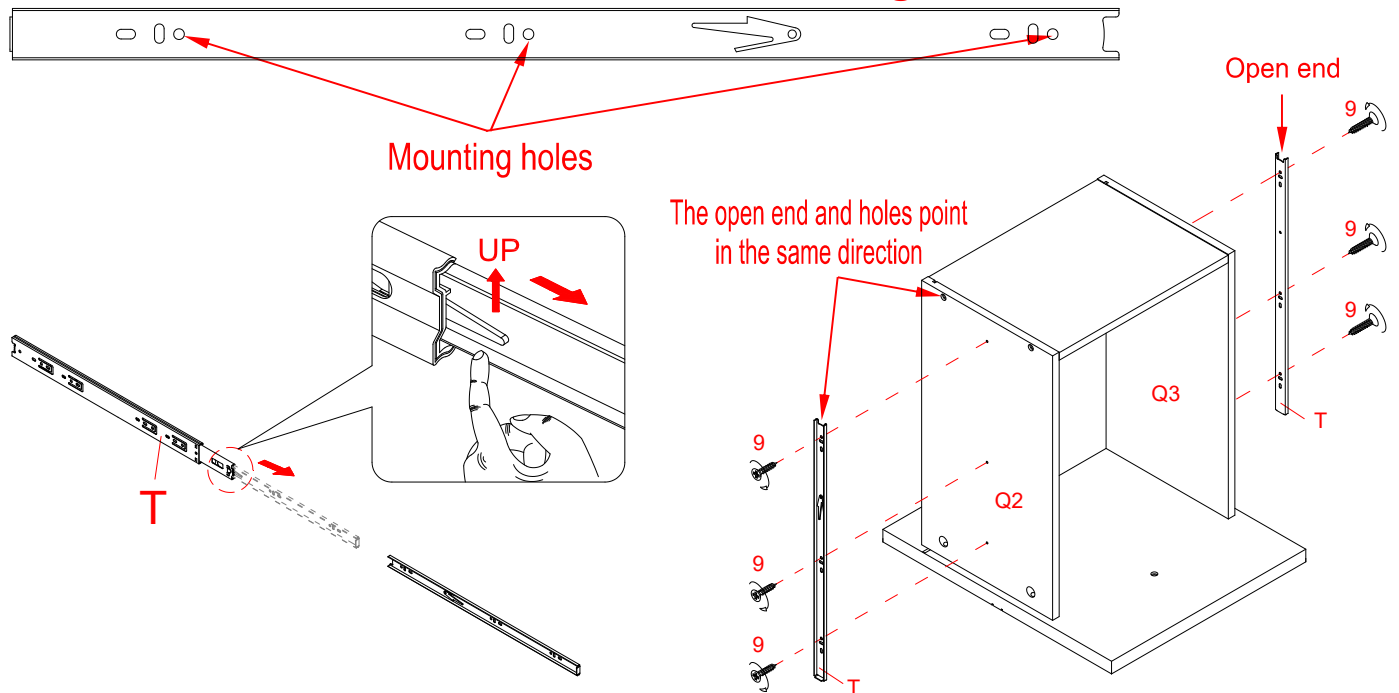

12. Pick up 16" Ball Bearing Slides (T) and separate the Slide Runners for later step. Extend the Slide Runner all the way forward. Press the plastic release lever of the ball bearing slides up and pull the Slide Runner complete out.
13. Using the pilot holes as a guide, attach the separated Slide Runners (T) to the Drawer Left and Right Sides (Q2 and Q3) respectively with three 1/2" Screws (9) per slide runner.

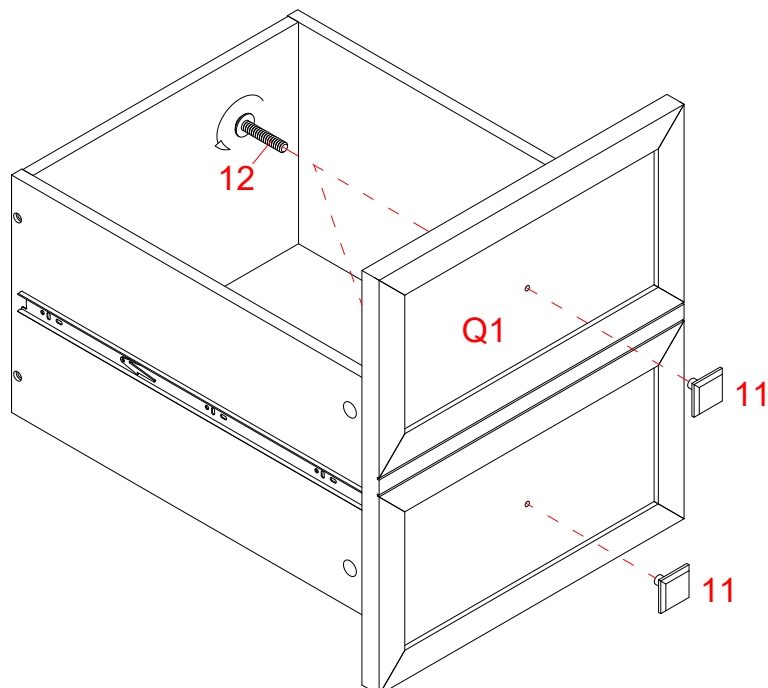

14. Turn the assembled drawer upright. Attach two Handles (11) to the outside of the Drawer Front (Q1) with two Handle Bolts (12).

## Assembly Instructions

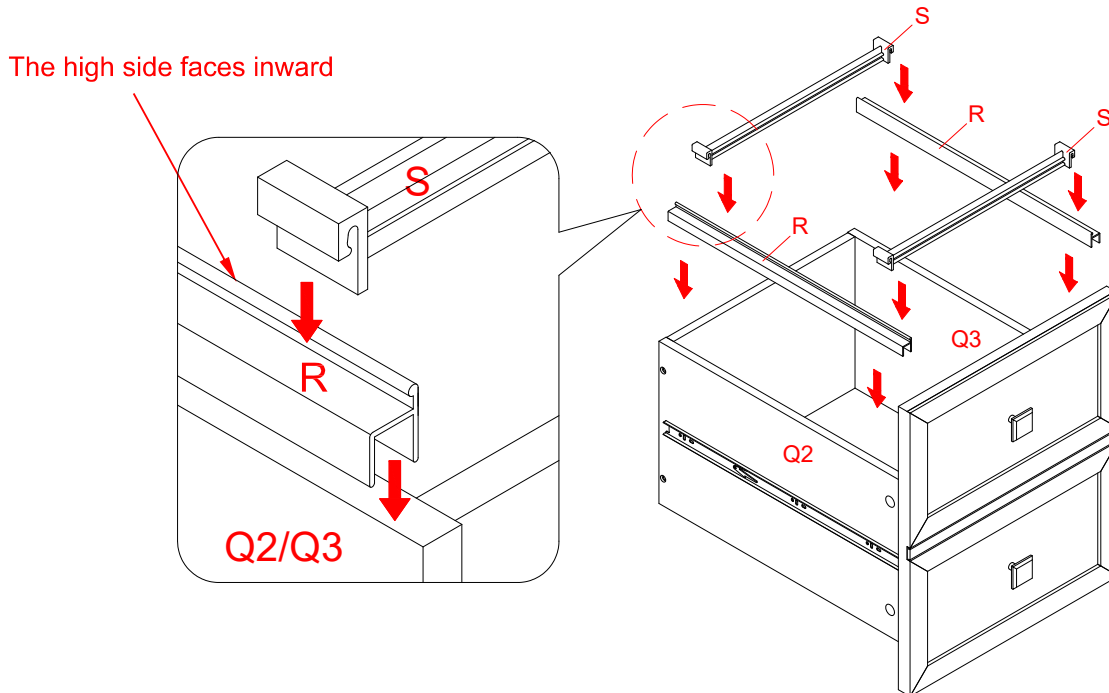

15. Position Guide Rails (R) onto the Drawer Left and Right Sides (Q2 and Q3) with the high side facing inward.
16. Hook two File Hangers (S) onto the high edge of Guide Rails (R). Slide the File Hangers forward and backward to keep hanging files organized.

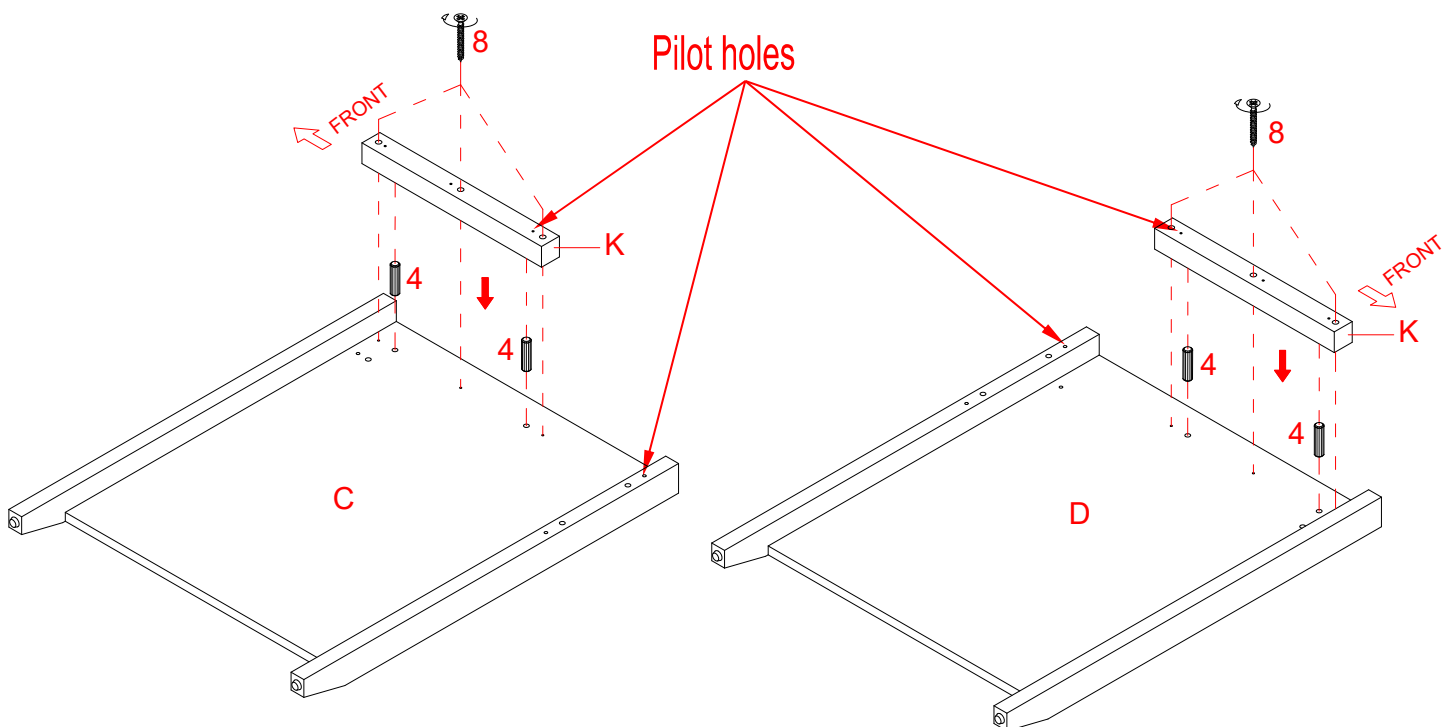

17. Using the pilot holes as a guide, attach the Slider Supports (K) to the Partition Panels (C and D) respectively with two M8 x 30 mm Wood Dowels (4) and three 38 mm Screws (8) per Support.

## Assembly Instructions

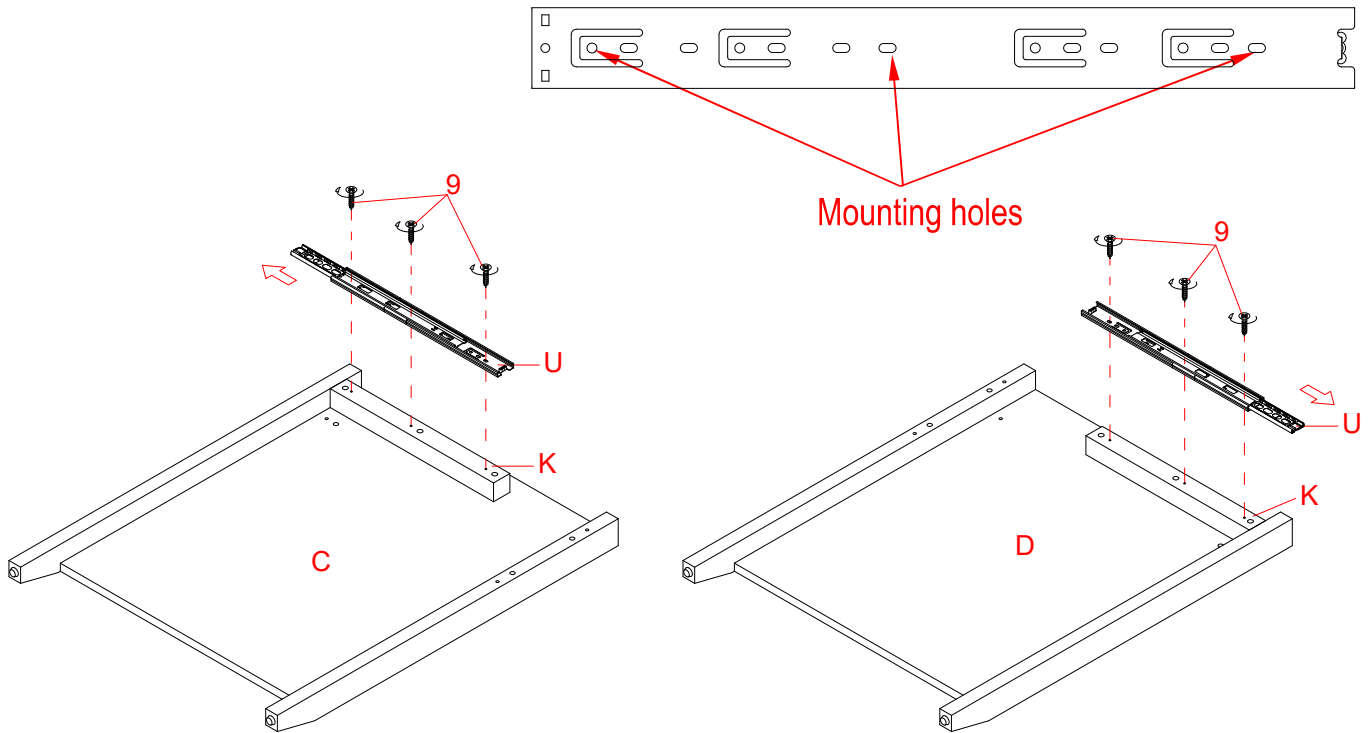

18. Using the pilot holes as a guide, attach separated 14" Slide Tracks (U) to the Slider Supports (K) respectively with three 1/2" Screws (9) per slide track.

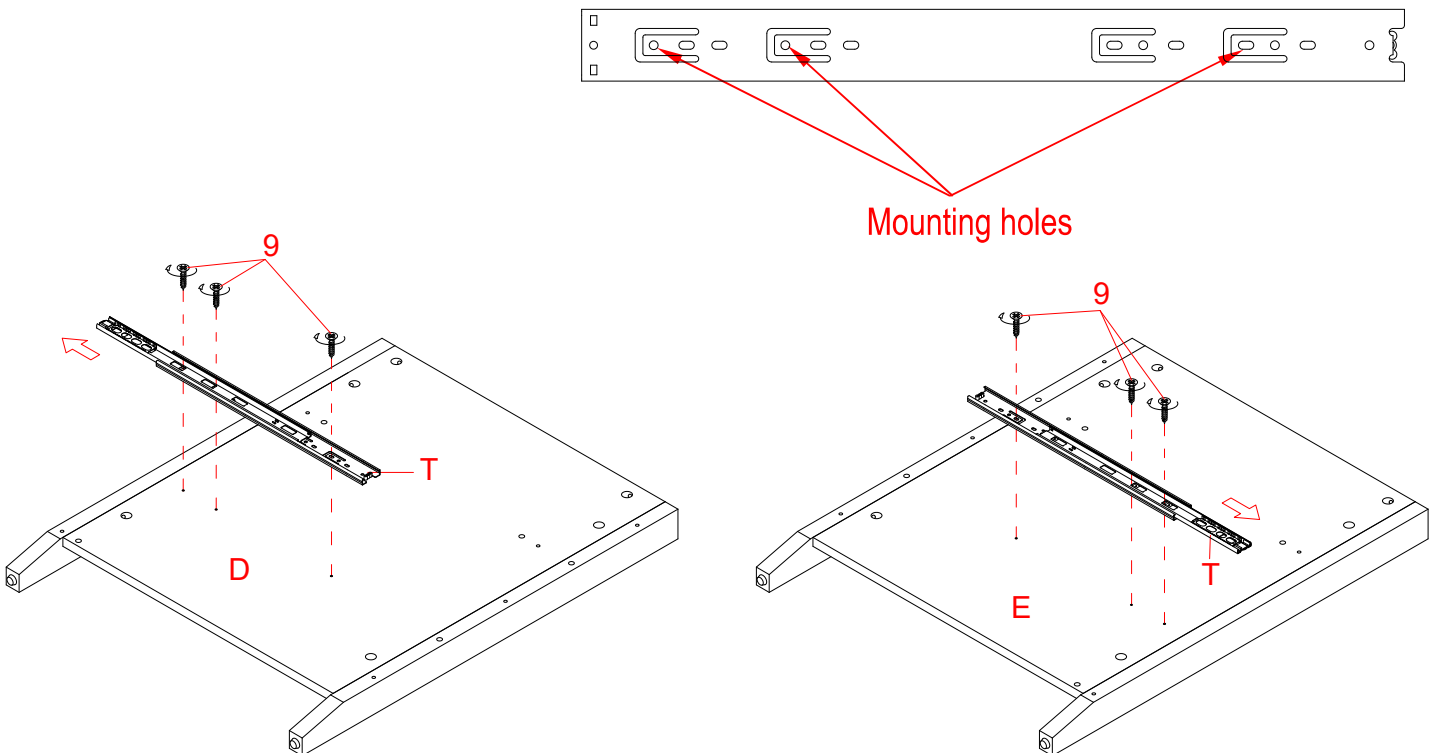

19. Using the pilot holes as a guide, attach separated 16" Slide Tracks (T) to the Panels (D and E) respectively with three 1/2" Screws (9) per slide track.

# Assembly Instructions

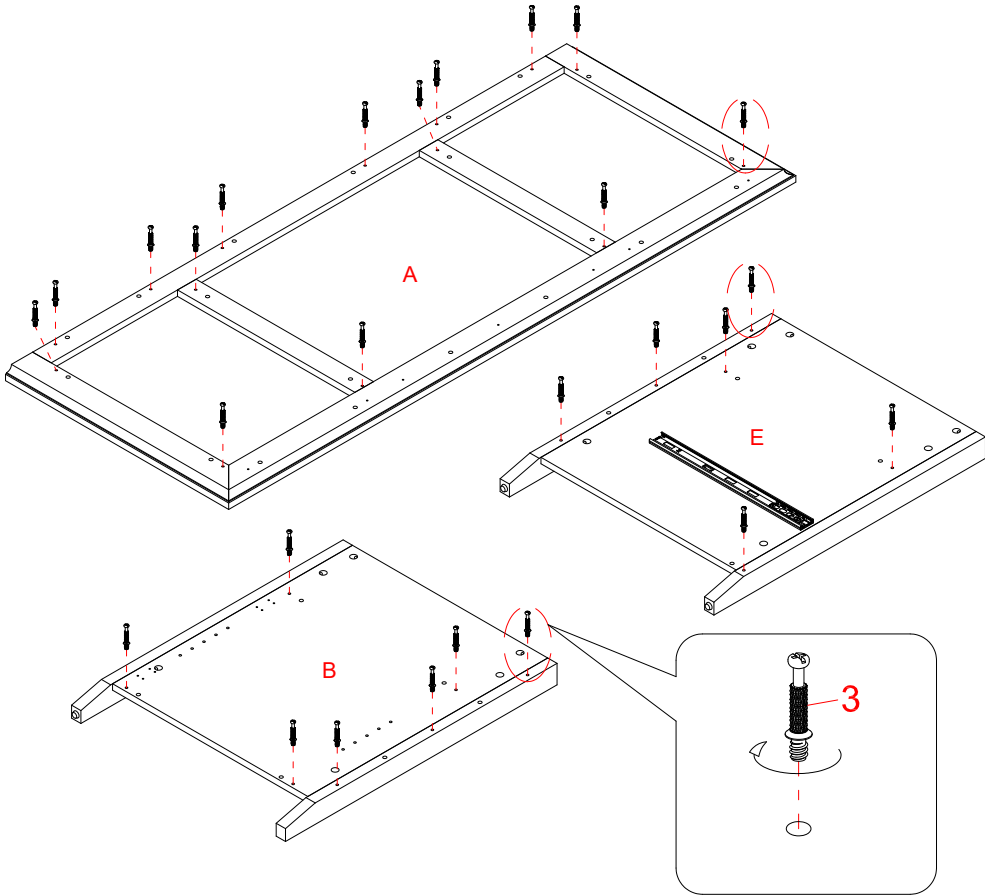

20. Securely screw the Cam Bolts (3) into the designated small holes on the Panels (A, B and E).

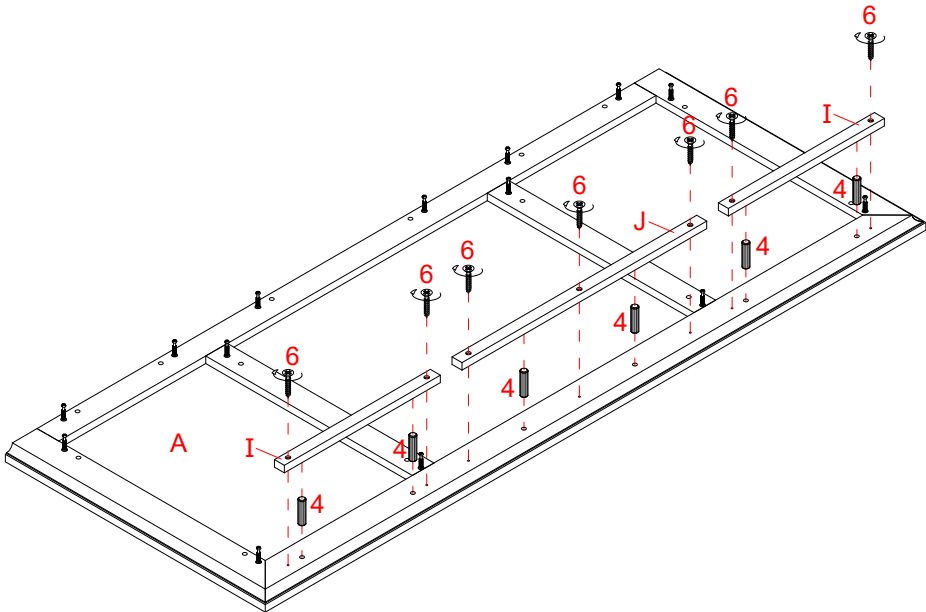

21. Attach the Top Stretchers (I and J) to the Desk Top (C) with six M8 x 30 mm Wood Dowels (4) and seven 25 mm Screws (6).

# Assembly Instructions

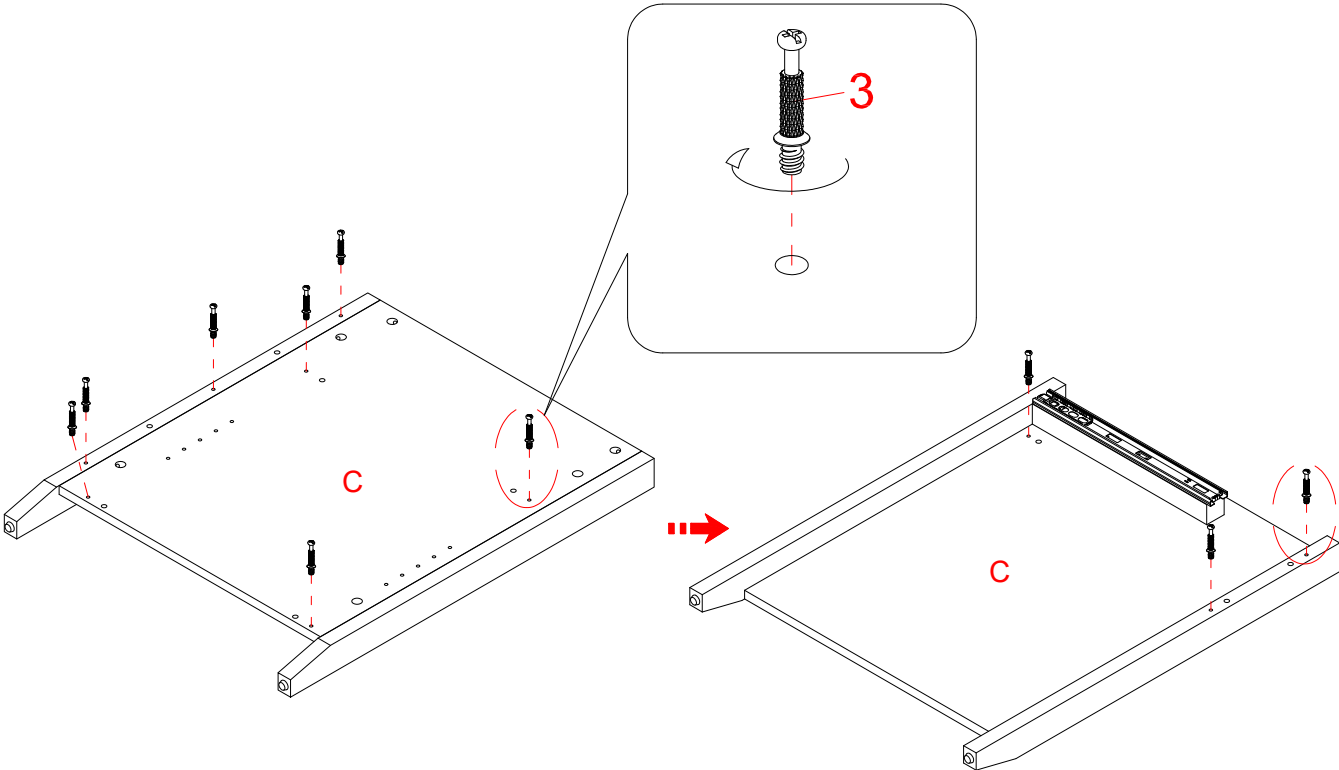

22. Securely screw the Cam Bolts (3) into the designated small holes on the Left Partition Panel (C) at both sides.

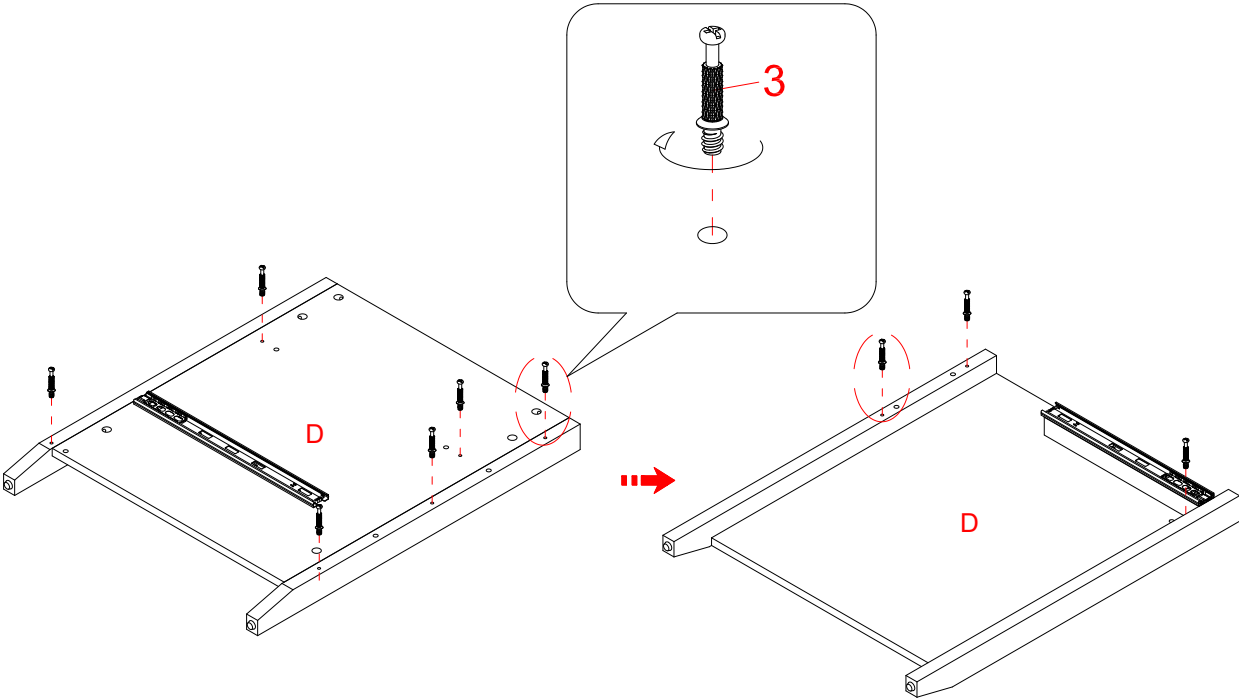

23. Securely screw the Cam Bolts (3) into the designated small holes on the Right Partition Panel (D) at both sides.

## Assembly Instructions

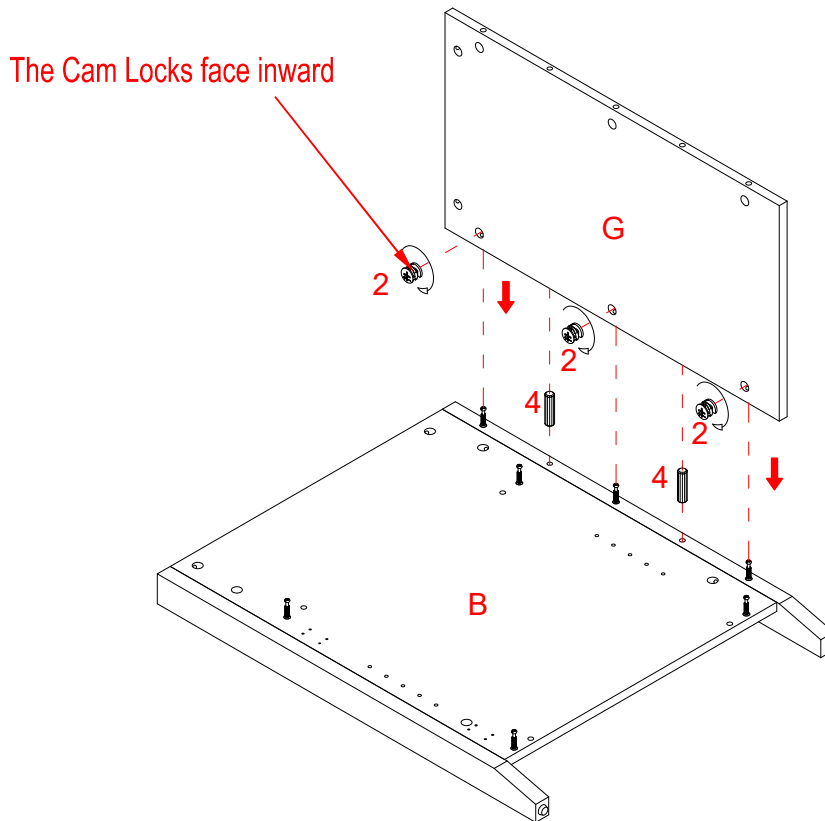

24. Attach one Side Back Panel (G) to the Left Side Panel (B) with two M8 x 30 mm Wood Dowels (4) and three Large Cam Locks (2).

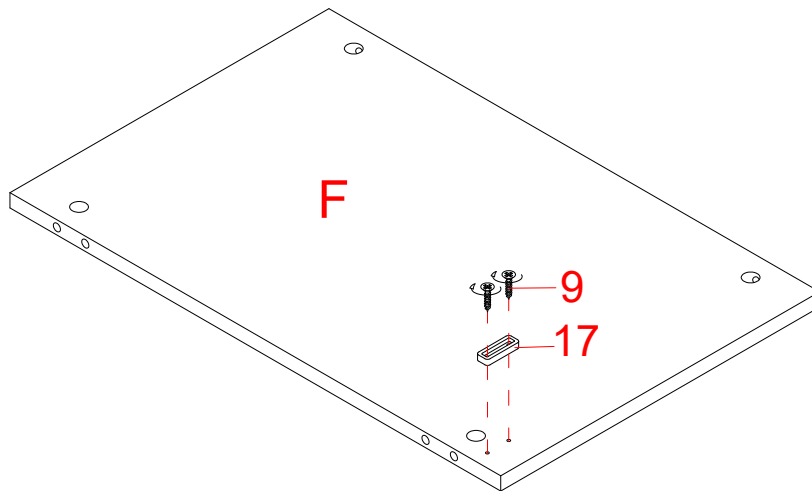

25. Using the pilot holes as a guide, attach the Door Stopper (17) to the bottom of Fixed Shelf (F) with two M3.5 x 12 mm Screws (9).

# Assembly Instructions

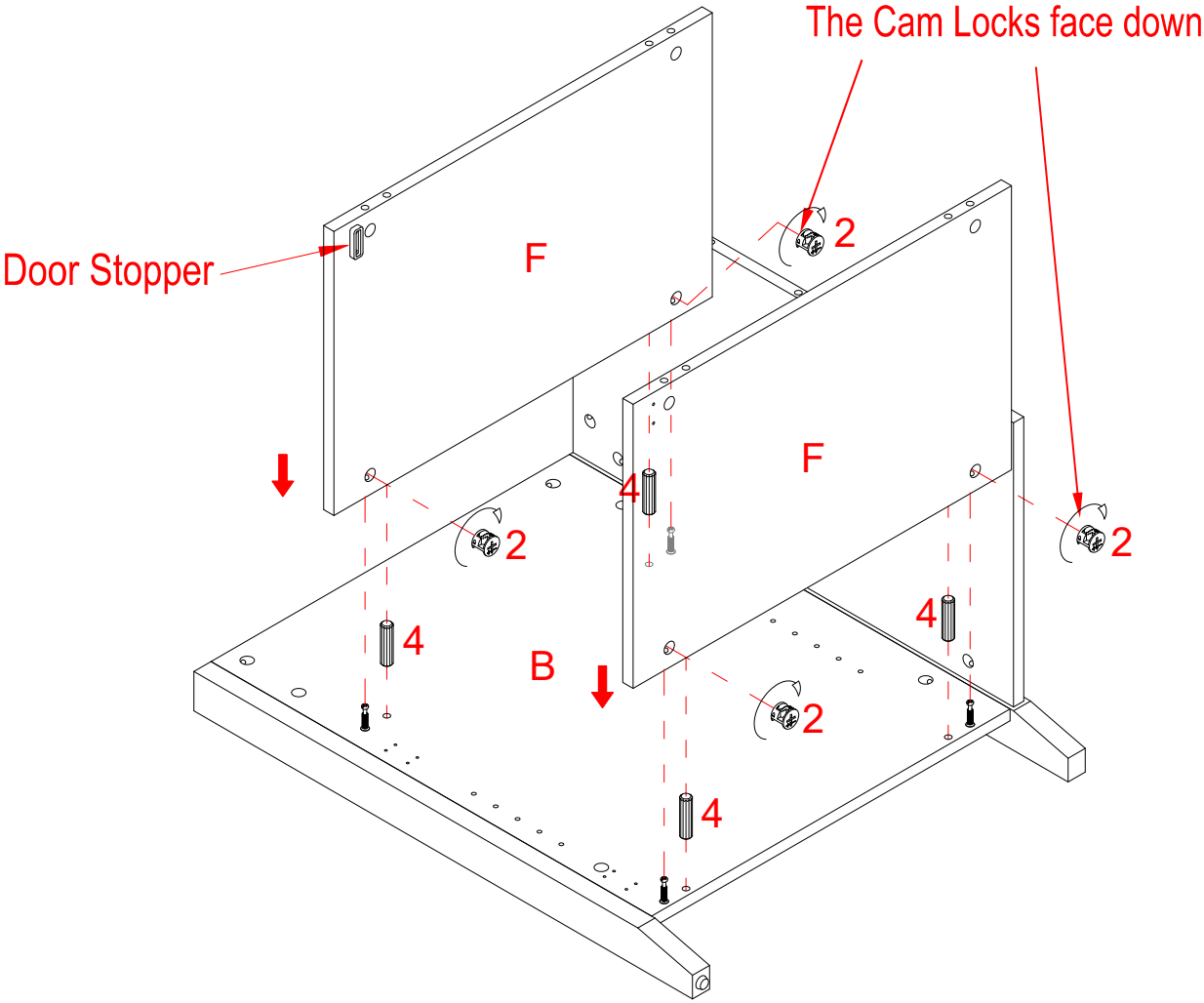

26. Attach the Fixed Shelves (F) to the Left Side Panel (B) with two M8 x 30 mm Wood Dowels (4) and two Large Cam Locks (2) in each.



## Assembly Instructions

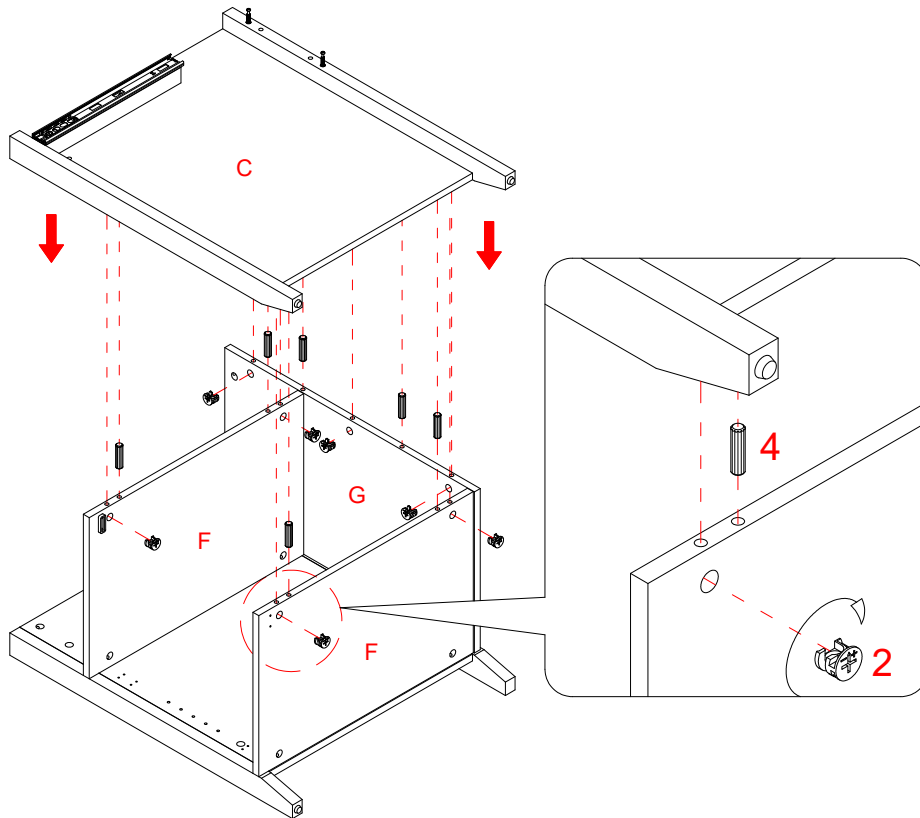

27. Repeat the same procedure to attach the Left Partition Panel (C) at the opposite end.

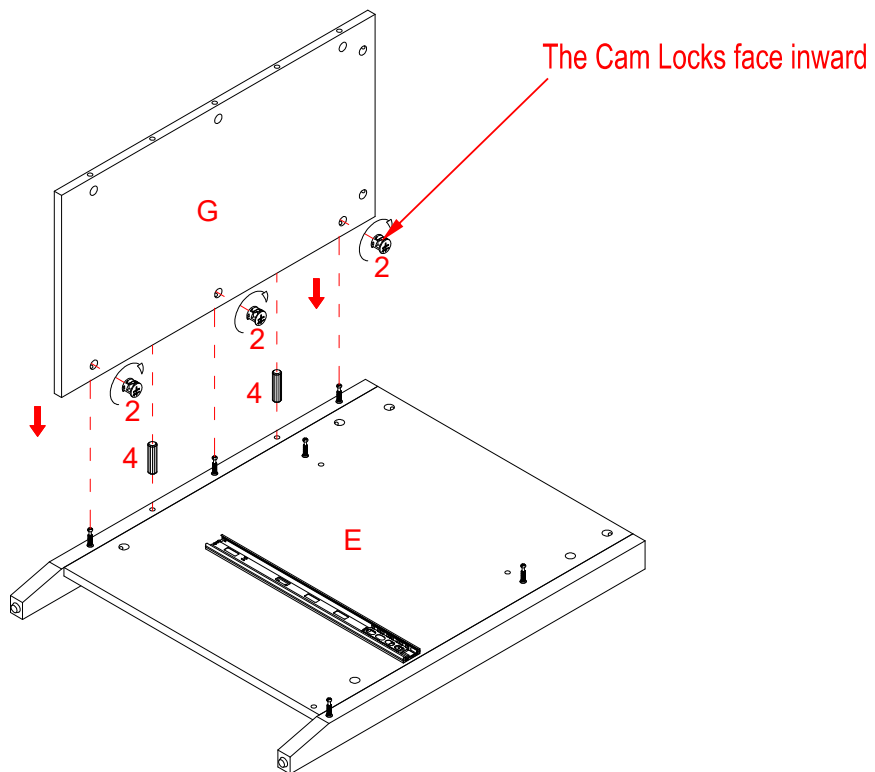

28. Attach the other Side Back Panel (G) to the Right Side Panel (E) with two M8 x 30 mm Wood Dowels (4) and three Large Cam Locks (2).

## Assembly Instructions

The Cam Locks will face the floor when the unit is turned upright

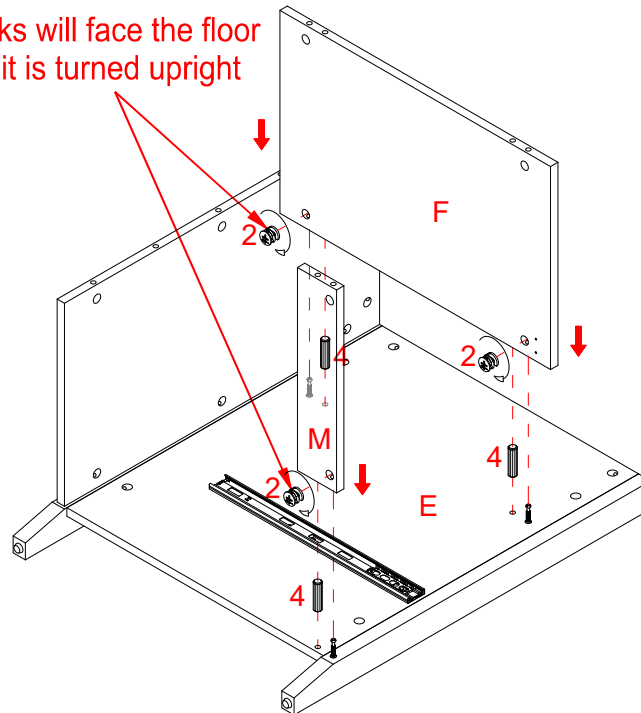

29. Attach the Fixed Shelf (F) to the Right Side Panel (E) with two M8 x 30 mm Wood Dowels (4) and two Large Cam Locks (2).

30. Fasten the Side Stretcher (M) to the Right Side Panel (E) with one M8 x 30 mm Wood Dowel (4) and one Large Cam Lock (2).

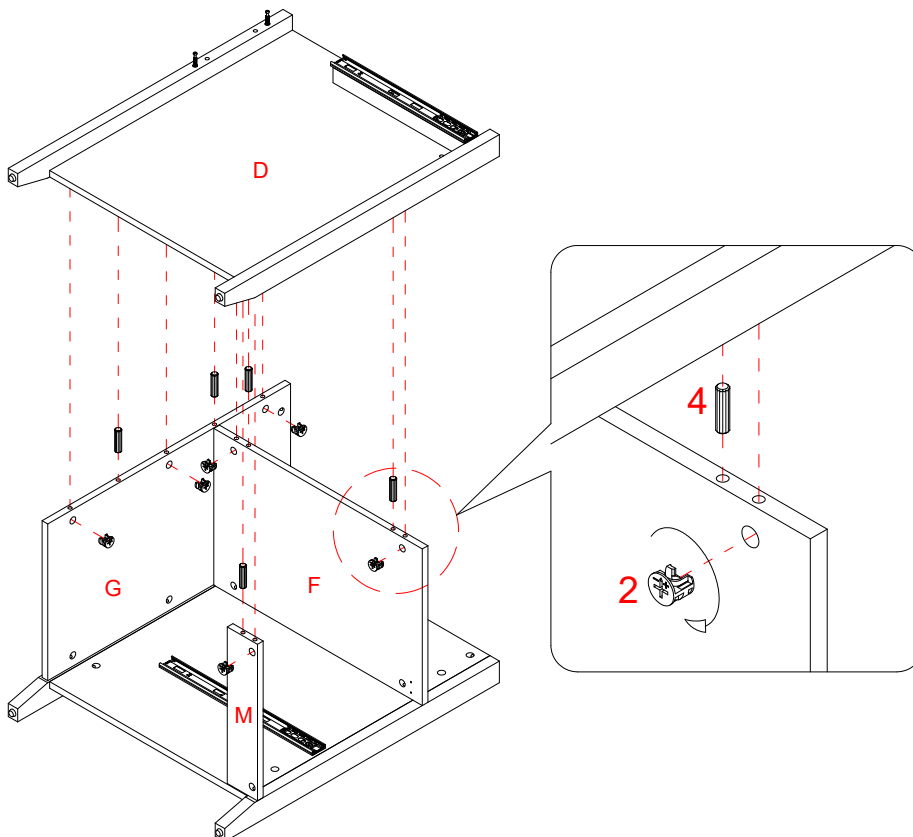

31. Repeat the same procedure to attach the Right Partition Panel (D) at the opposite end.

## Assembly Instructions

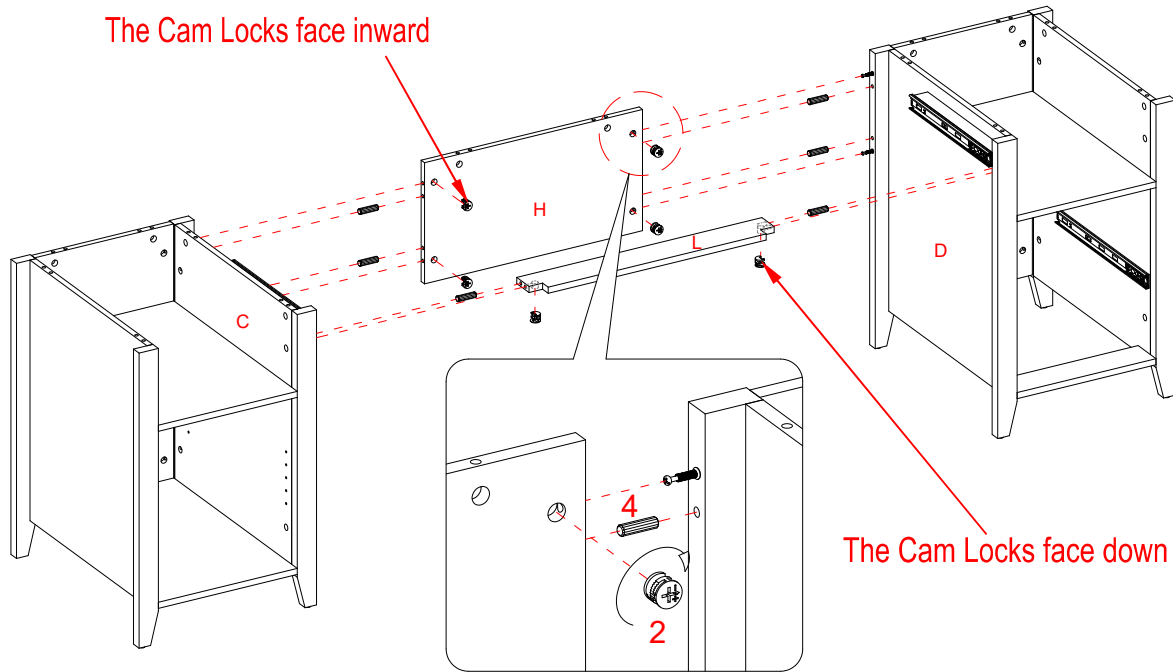

32. Attach the Middle Back Panel (H) to the Right Partition Panel (D) with two M8 x 30 mm Wood Dowels (4) and two Large Cam Locks (2).
33. Fasten the Middle Stretcher (L) to the Right Partition Panel (D) with one M8 x 30 mm Wood Dowel (4) and one Large Cam Lock (2).
34. Repeat the same procedure to attach the Left Partition Panel assembly at the opposite end.

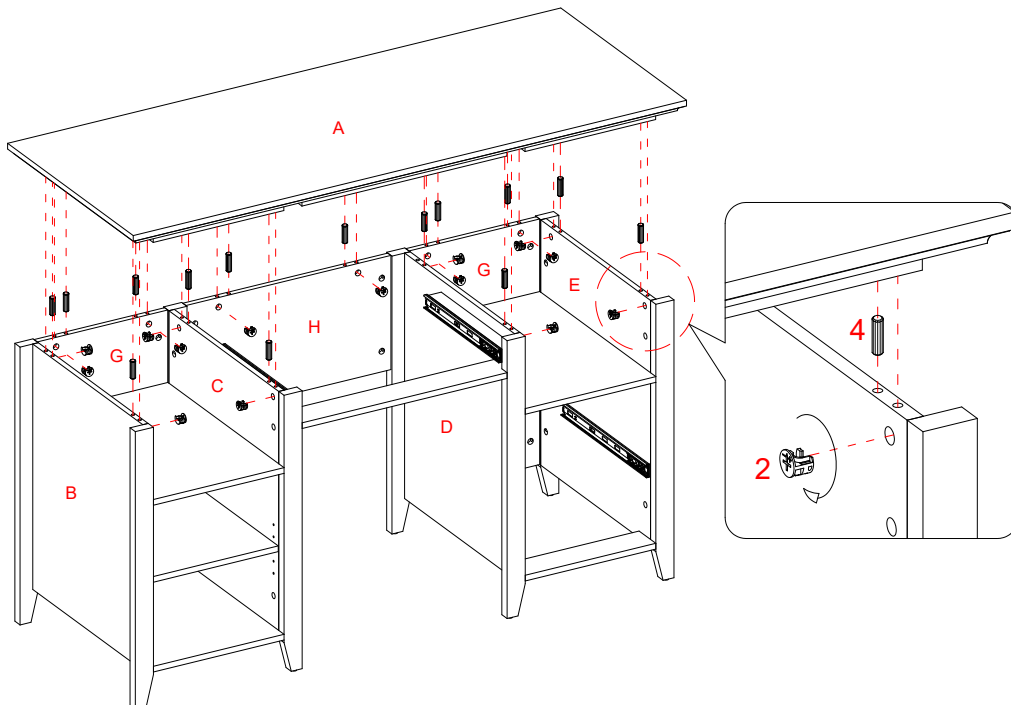

35. Glue fourteen M8 x 30 mm Wood Dowels (4) into the top holes of the Panels (B, C, D, E, G and H). Position the Desk Top (A) onto the inserted Wood Dowels (4) and secure it in place with fourteen Large Cam Locks (2).

## Assembly Instructions

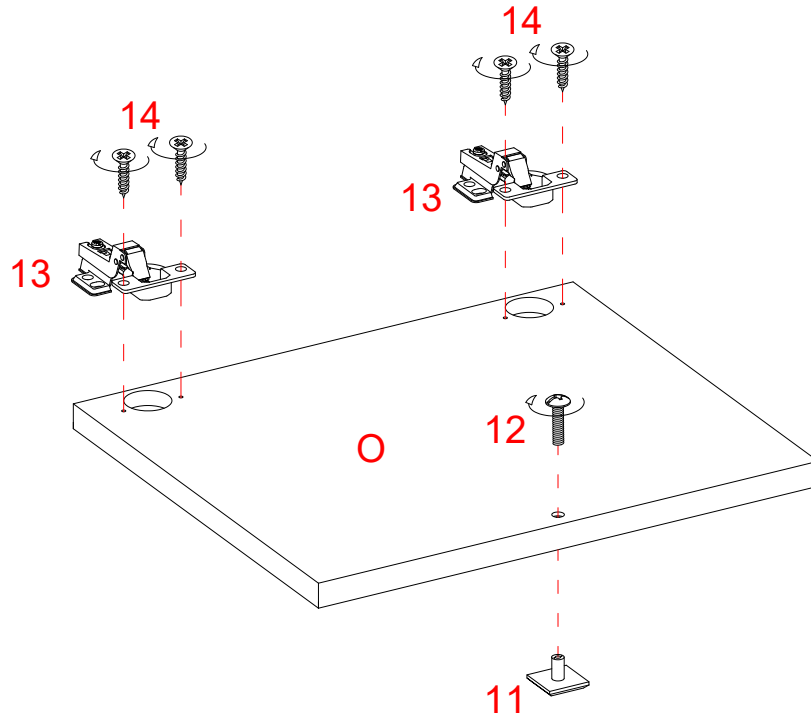

36. Extend the Hinges Arms (13) and rest the Hinge Cups onto the cutouts of the Door (O). Secure the Hinge Arms in place by using two 15 mm Zinc Screws (14) in each.

37. Attach one Handle (11) to the front side of Door (O) with the provided Handle Bolt (12).

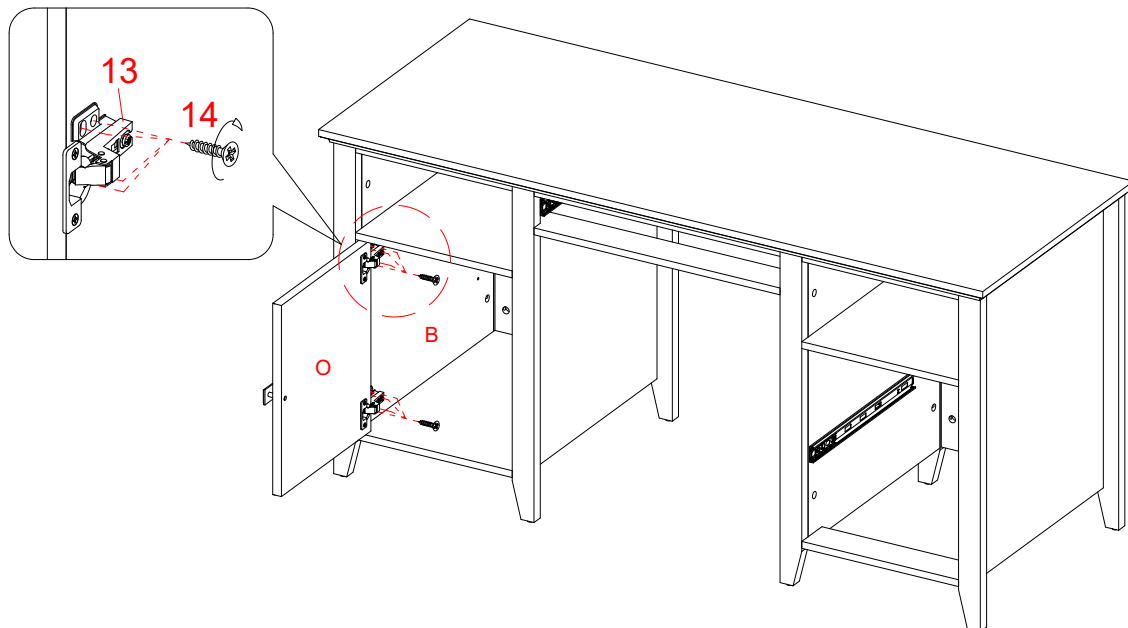

38. Using the pilot holes as a guide, pick up the Door (O) and fasten the hinge bases onto the Left Side Panel (B) with four 12 mm Zinc Screws (14) in each.

39. Open and close the doors to make sure they are aligned and shut correctly. If necessary, adjust the screws for a good fit. Refer to the hinge sticker on door for adjustment.

## Assembly Instructions

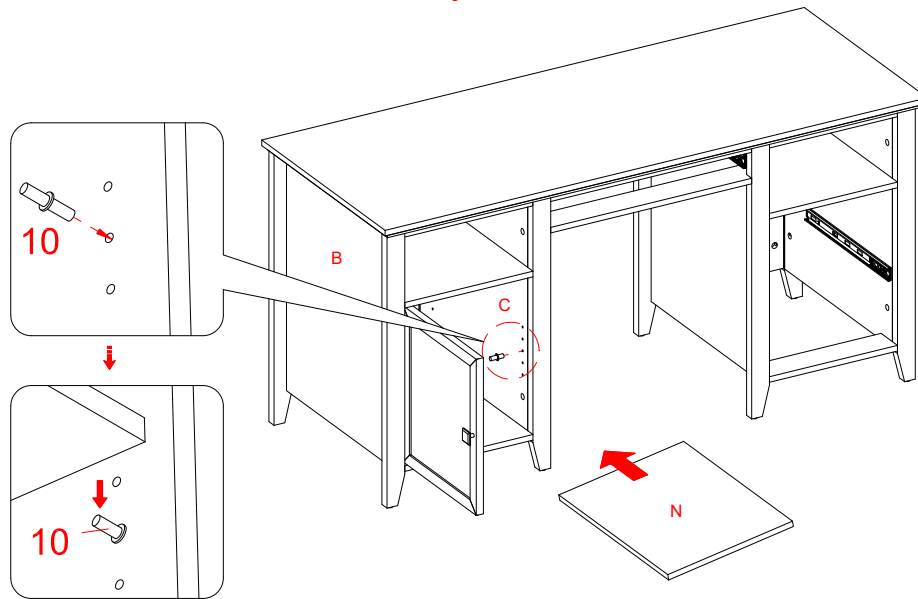

40. Insert the Shelf Pins (10) into the desired holes in the sides of the compartment. Make sure you place four Shelf Pins in the same level so the shelf is not tilted. Tilt and rest the Adjustable Shelf (N) onto the Shelf Pins (10).

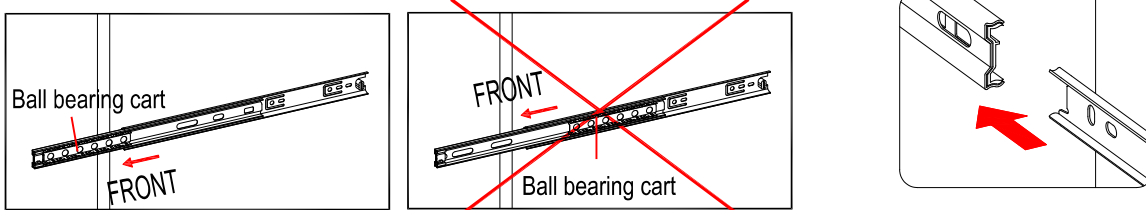
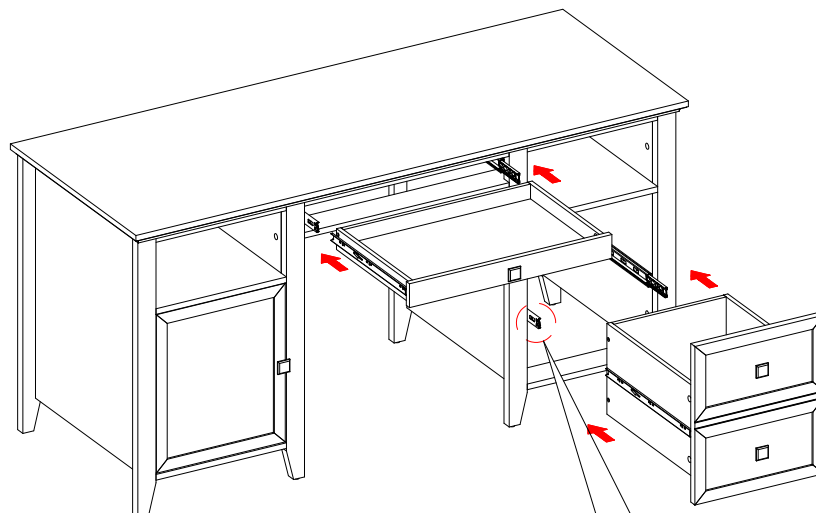

### Drawer Installation

41. Insert the assembled Drawer into desk frame. Extend the Ball Bearing Slide Tracks on the Panels all the way forward (including ball bearing cart). Then align the Slide Runners on the assembled drawers with the Slide Tracks and push the drawer carefully inside until it stops.

**NOTE:** If the drawer does not go in smoothly, please take it out and repeat the step. If you need to remove the drawer, please pull the drawer all the way out, then simultaneously push the plastic release lever of the ball bearing slides up on one side and down on the other side, and then pull it completely out.

## Assembly Instructions

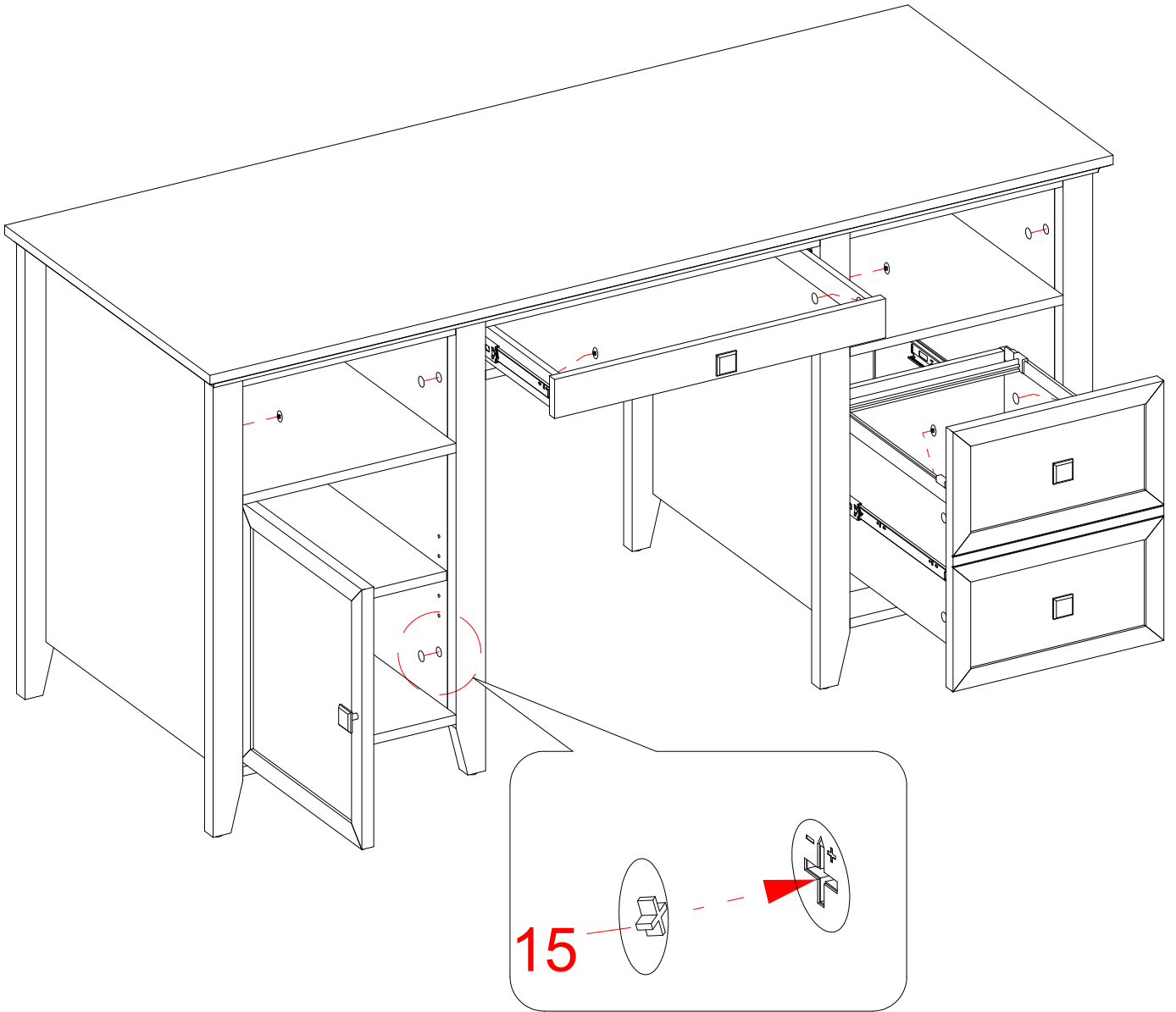

42. Plug the Cam Lock Covers (15) onto the visible cams locks to conceal the cams.

## Care and Maintenance

- Use a soft, clean cloth that will not scratch the surface when dusting.
- Use of furniture polish is not necessary. Should you choose to use polish, test first in an inconspicuous area.
- Using solvents of any kind on your furniture may damage your furniture's finish.
- Never use water to clean your furniture as it may cause damage to the finish.
- Always use coasters under beverage glasses and flowerpots.
- Liquid spills should be removed immediately. Using a soft, clean cloth, blot the spill gently. Avoid rubbing.
- Always use protective pads under hot dishes and plates. Heat can cause chemical changes that may create spotting within the furniture finish.
- In the event that your furniture is stained or otherwise damaged during use, we recommend that you call a professional to repair your furniture.
- Check bolts/screws periodically and tighten them if necessary.

## Further Advice about Wood Furniture Care

It is best to keep your furniture in a climate-controlled environment. Extreme temperature and humidity changes can cause fading, warping, shrinking and splitting of wood. It is advised to keep furniture away from direct sunlight as sun may damage the finish.

Proper care and cleaning at home will extend the life of your purchase. Following these important and helpful tips will enhance your furniture as it ages.

We hope you enjoy your purchase for many years.  
Thank you for your purchase!

## QUALITY GUARANTEE

We are confident that you will be delighted with your Whalen Furniture purchase.

Should this product be defective in workmanship or materials or fail under normal use, we will repair or replace it for up to one (1) year from date of purchase. Every Whalen Furniture product is designed to meet your highest expectations. We guarantee that you will immediately see the value of our fine furniture.

This warranty gives you specific legal rights and you may also have other rights which vary from state to state or province to province.

Customer Service: 1-866-942-5362  
8:30 a.m. - 4:30 p.m., PST, Monday to Friday  
[www.whalenfurniture.com](http://www.whalenfurniture.com)