

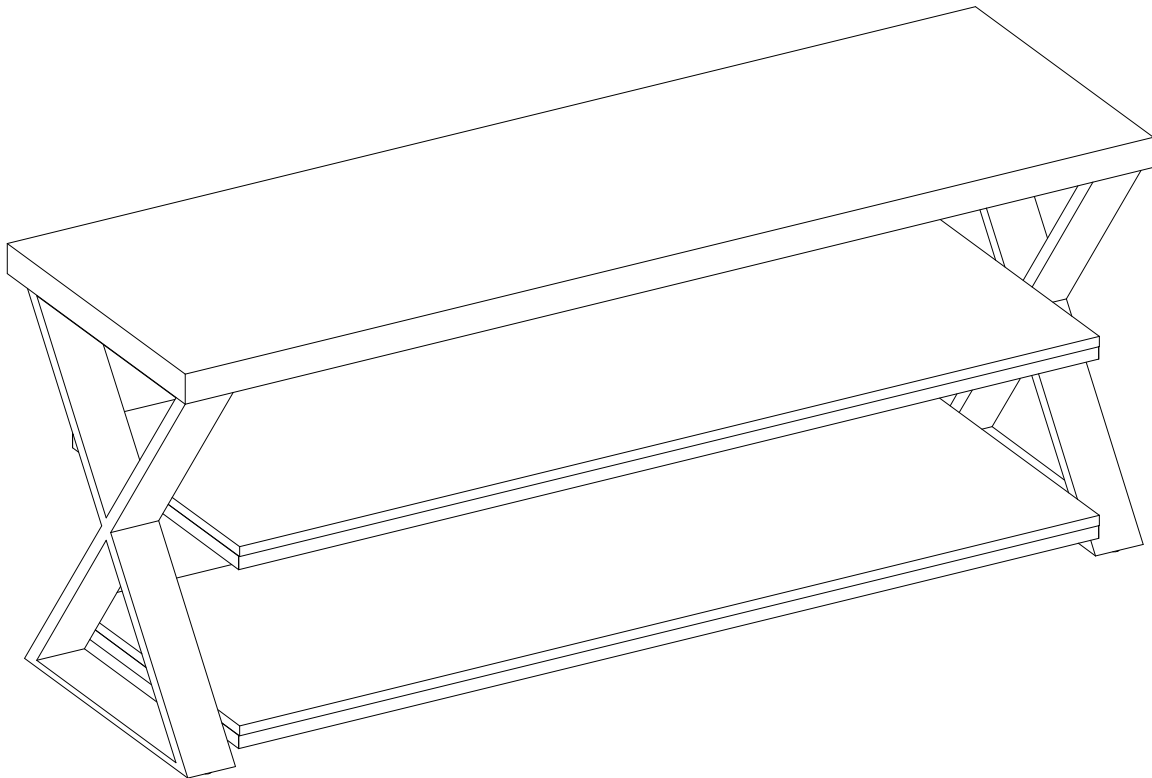

LOT NUMBER: \_\_\_\_\_  
DATE PURCHASED: \_\_/\_\_/\_\_

# 60" TV Console

## Model # BBAVC60-MBC



### **ADULT ASSEMBLY REQUIRED**

If you have any questions regarding assembly or if parts are missing, DO NOT return this item to the store where it was purchased. Please call our toll-free customer service number and have your instructions and parts list ready to provide the model name, part name or factory number:

**1-866-942-5362**

Pacific Standard Time: 8:30 a.m. - 4:30 p.m., Monday to Friday  
Or visit our website 24 hours a day, 7 days a week for product assistance at

**[www.whalenfurniture.com](http://www.whalenfurniture.com)**

Or e-mail your request to **[parts@whalenfurniture.com](mailto:parts@whalenfurniture.com)**

**THIS INSTRUCTION BOOKLET CONTAINS IMPORTANT SAFETY INFORMATION.  
PLEASE READ AND KEEP FOR FUTURE REFERENCE.**

Date 2017-04-09 Rev. 0001-A Factory: FOCIDI

## MAXIMUM RECOMMENDED WEIGHT LOADS

MANUFACTURER: Whalen Furniture Manufacturing  
CATALOG: 60" TV Console (BBAVC60-MBC)  
MADE IN CHINA

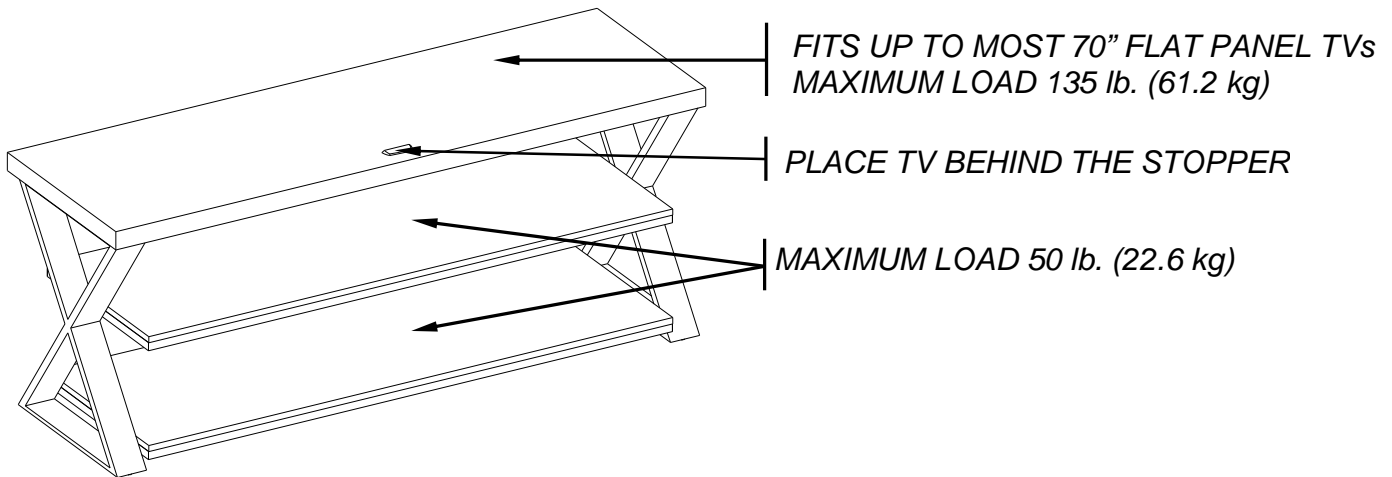

### **WARNING**

THIS UNIT IS NOT INTENDED FOR USE WITH CRT TVS. USE ONLY WITH FLAT PANEL TVS AND AUDIO/VIDEO EQUIPMENT MEETING RECOMMENDED SIZE AND WEIGHT LIMITS. NEVER USE WITH LARGER/HEAVIER THAN RECOMMENDED FLAT PANEL TVS OR EQUIPMENT. TO AVOID INSTABILITY, PLACE FLAT PANEL TV IN THE CENTER OF THE UNIT; THE BASE OF THE TELEVISION MUST BE ABLE TO REST ON THE SUPPORTING SURFACE OF THE UNIT WITHOUT OVER-HANGING THE EDGES. IMPROPERLY POSITIONED FLAT PANEL TVS, OR FLAT PANEL TVS INCLUDING OTHER EQUIPMENT THAT EXCEED RECOMMENDED SIZE AND WEIGHT LIMITS COULD FALL OFF OR BREAK THE UNIT, CAUSING POSSIBLE SERIOUS INJURY.

## GENERAL INFORMATION, TIPS AND TRICKS

1. Please read the Assembly Instructions prior to assembling this product.
2. Remove all hardware from the box and sort by size.
3. Check to see that all hardware and parts are present BEFORE assembling.
4. Ask a friend to assist you with the assembly of this furniture.
5. To avoid damage, assemble the product on a sturdy, level and protective surface.
6. Please wait until all steps are completed before fully tightening bolts.
7. Make sure all bolts are tightly fastened before the unit is used.

This product is sold with one set of Tipping Restraint Hardware Kit. You must install the Tipping Restraint Hardware between the wall and the console to prevent any accidents or damages. When properly installed, this restraint can provide protection against the unexpected tipping of the unit due to small tremors, bumps or climbing. The restraint is only a deterrent and is not a substitute for proper adult supervision. Use of tip-over restraints may only reduce, but not eliminate, the risk of tip-over.

## Parts and Hardware List

Please read completely through the instructions and verify that all listed parts and hardware are present before beginning assembly.

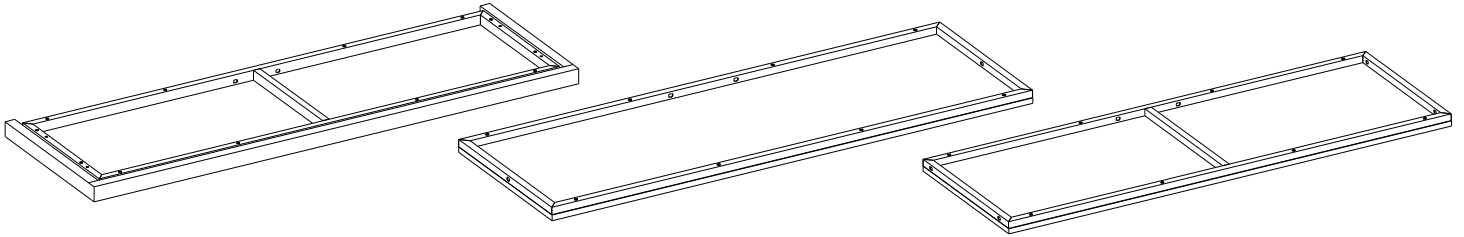

A- Top Panel (Qty. 1)

B- Middle Shelf (Qty. 1)

C- Bottom Shelf (Qty. 1)

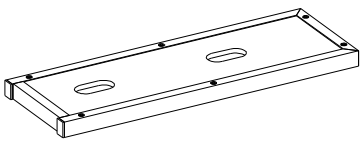

D- Back Frame (Qty. 1)

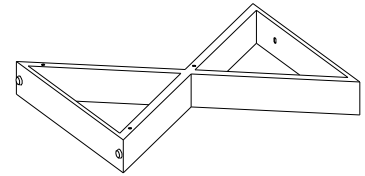

E- Left Leg (Qty. 1)

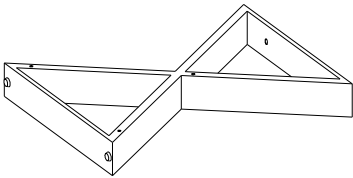

F- Right Leg (Qty. 1)

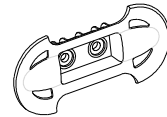

G- Cable Wheel (Qty. 2)

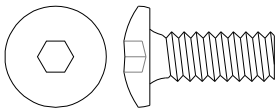

(1) 5/8" Bolt  
(Qty. 4+1 extra)

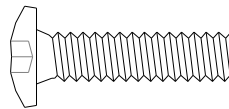

(2) 1" Bolt  
(Qty. 4+1 extra)

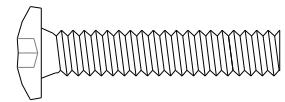

(3) 1-1/4" Bolt  
(Qty. 12+1 extra)



(4) Lock Washer  
(Qty. 16+1 extra)

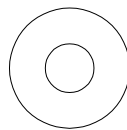

(5) Flat Washer  
(Qty. 16+1 extra)



(6) Acrylic Stopper  
(Qty. 1)

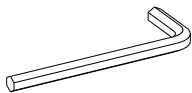

4 mm Hex Wrench  
(Qty. 1)

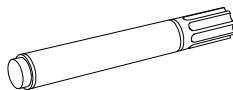

Touch-up Pen  
(Qty. 1)

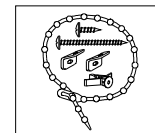

Tipping Restraint Hardware Kit (Qty. 1)  
**(Inside Plastic Bag)**

**Tools required: Hex wrench (provided) and Phillips screwdriver (not provided).**

## Assembly Instructions

The metal frame will face the floor when the unit is turned upright

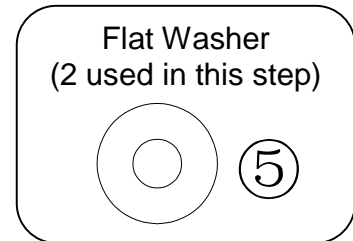
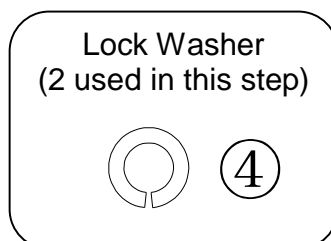
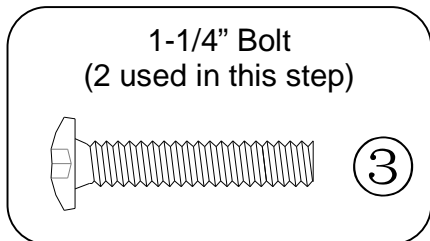
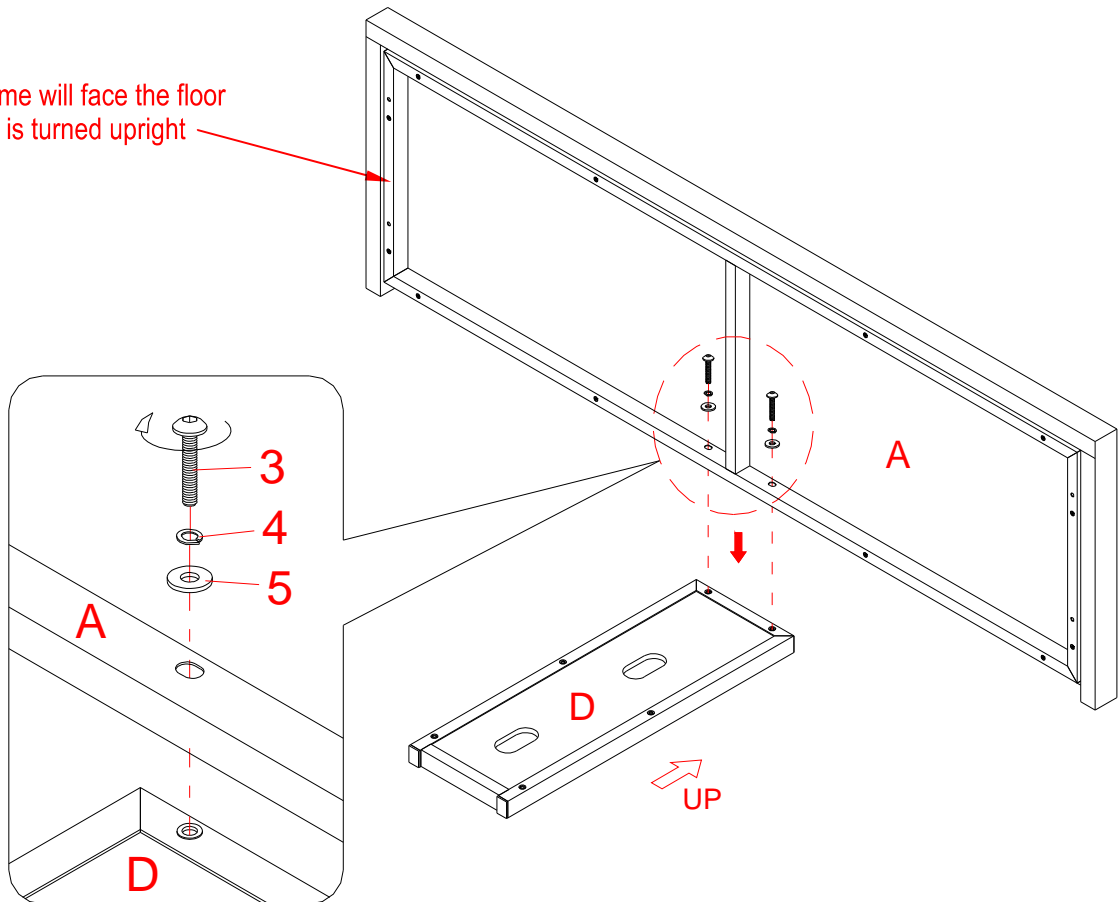

**NOTE:** Please do not fully tighten all bolts until you finish assembling all parts. Once assembled, go back and fully tighten all bolts. This will make the assembly easier.

1. Unpack the unit and confirm that you have all the hardware and required parts.
2. Locate the Back Frame (D) on a level and protective surface with the flush surfaces facing up.
3. Fasten the Top Panel (A) to the Back Frame (D) with two 1-1/4" Bolts (3) and two Washers (4 and 5).

## Assembly Instructions

The metal frame will face the floor when the unit is turned upright

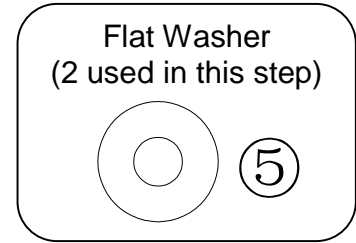
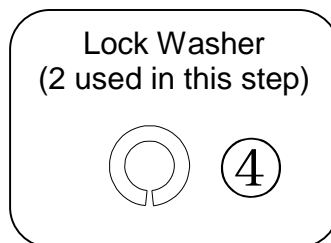
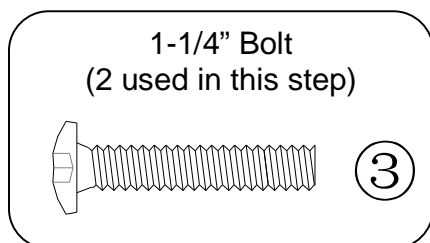
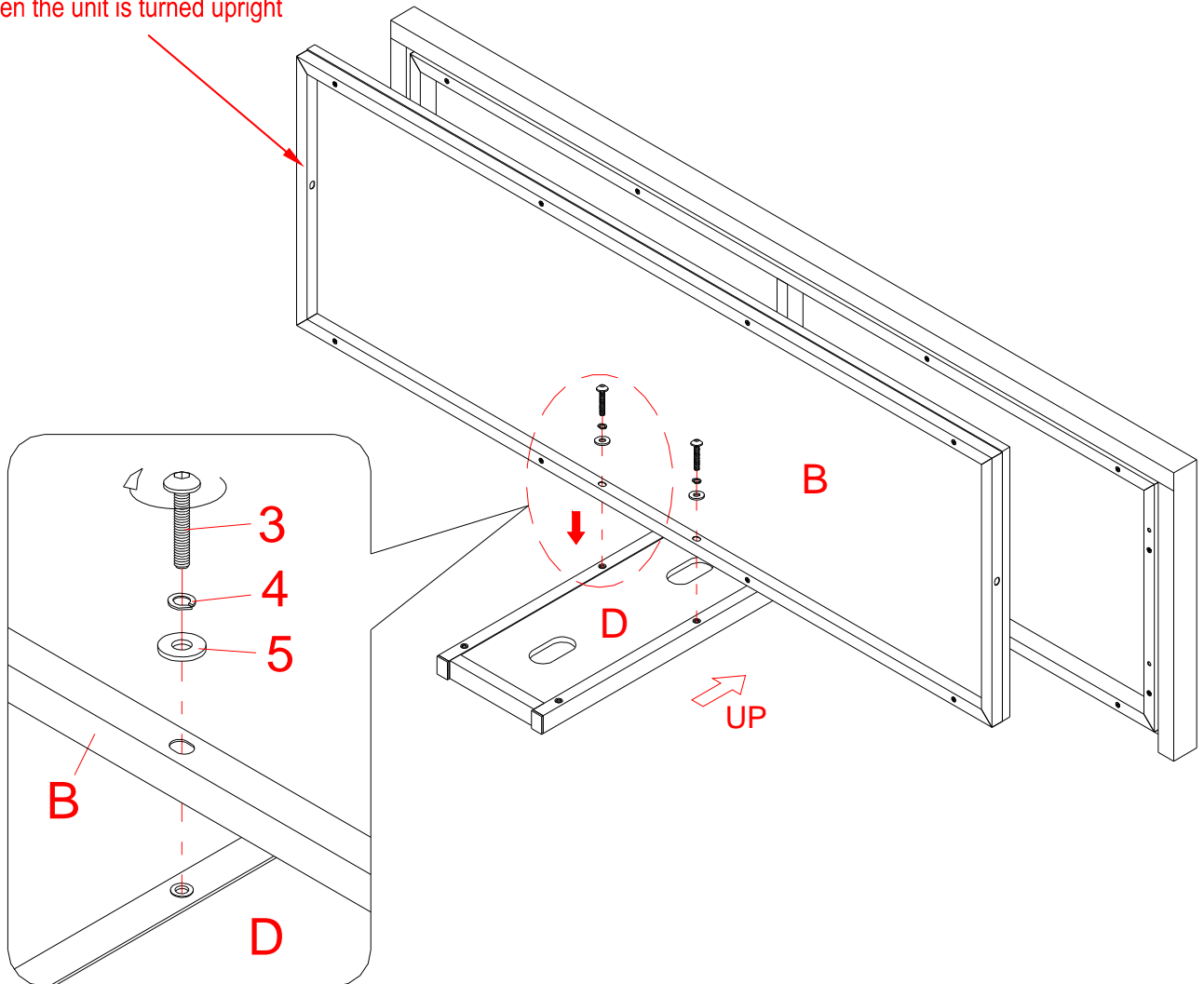

4. Fasten the Middle Shelf (B) to the Back Frame (D) with two 1-1/4" Bolts (3) and two Washers (4 and 5).

## Assembly Instructions

The metal frame will face the floor when the unit is turned upright

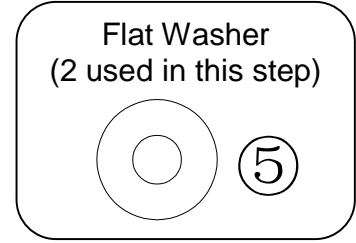
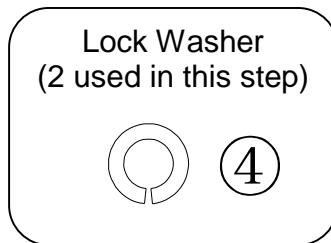
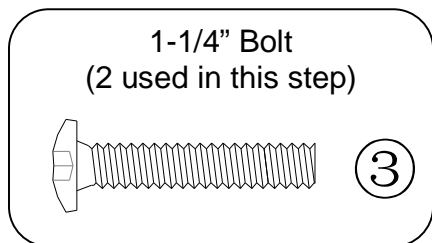
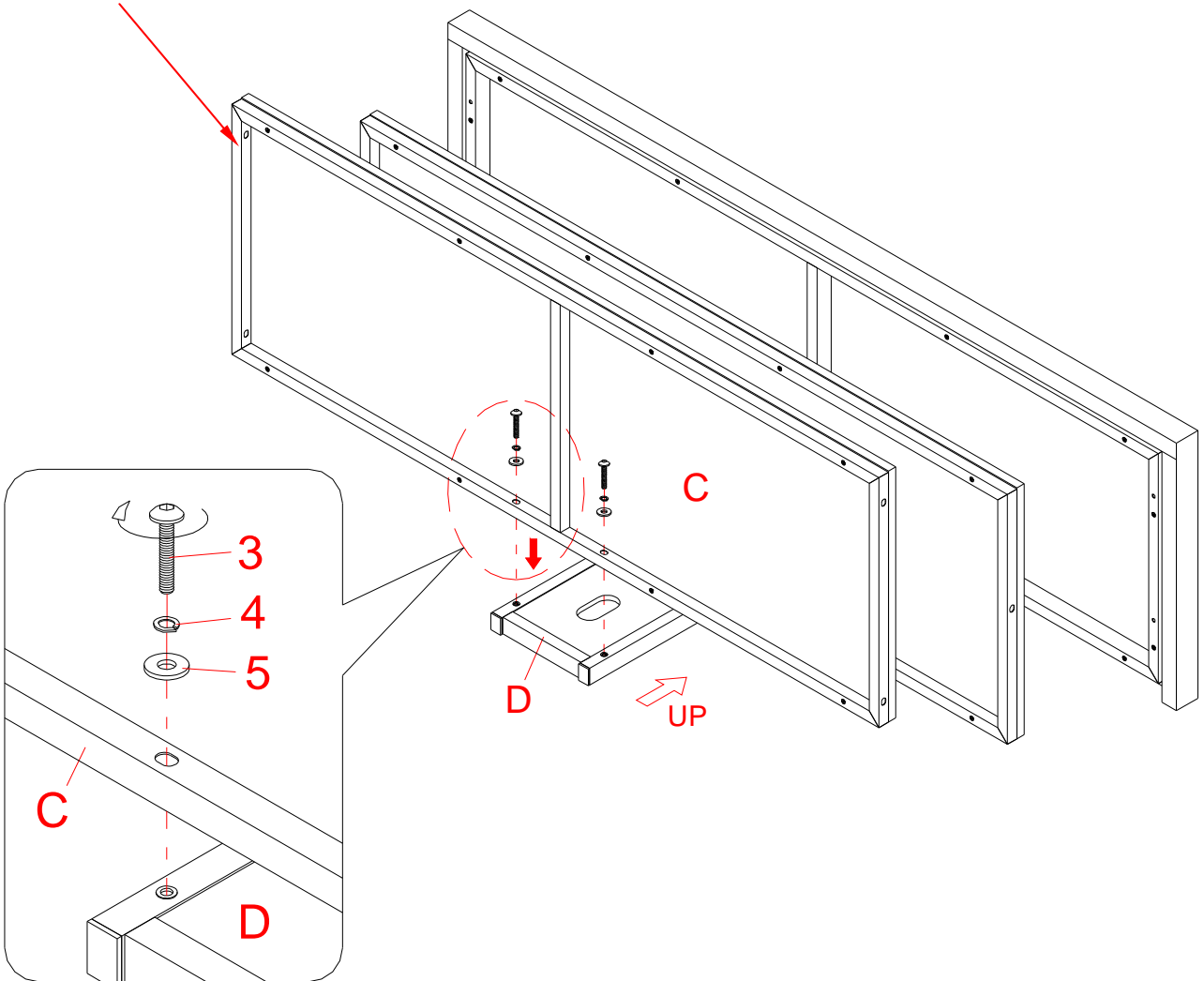

5. Attach the Bottom Shelf (C) to the Back Frame (D) with two 1-1/4" Bolts (3) and two Washers (4 and 5).

## Assembly Instructions

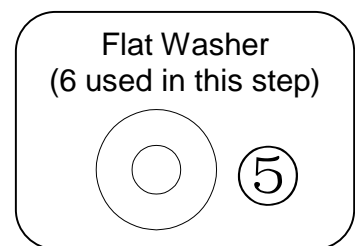
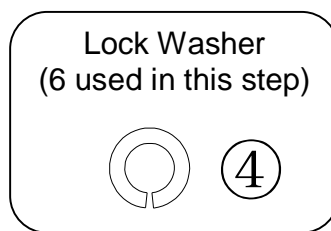
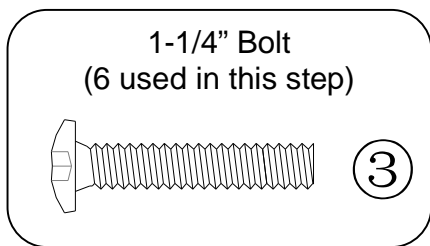
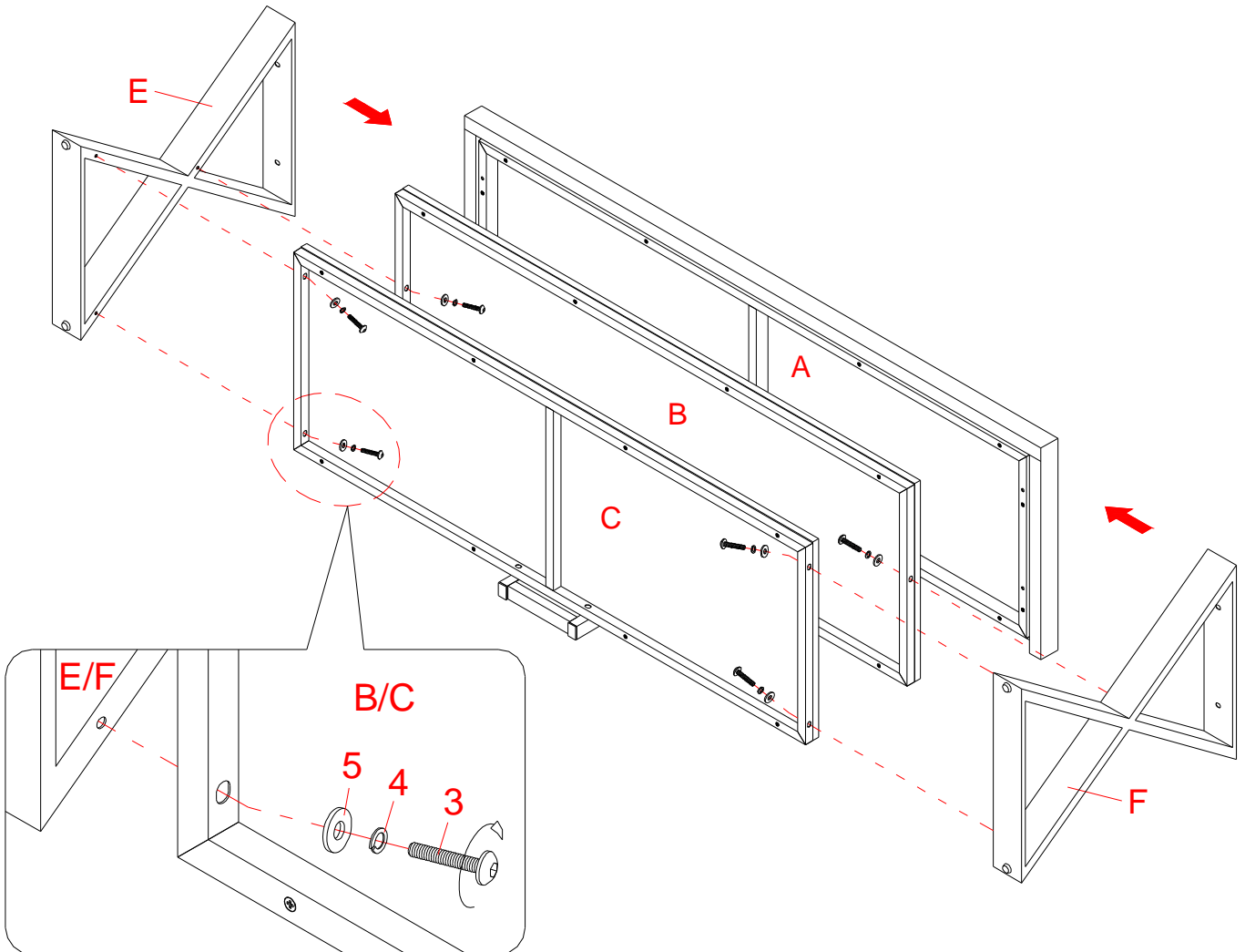

6. Align and attach Left Leg (E) to the Lower Shelf Frames (B and C) with three 1-1/4" Bolts (3) and three Washers (4 and 5).
7. Repeat the same procedure to attach the Right Leg (F) on the other side.

## Assembly Instructions

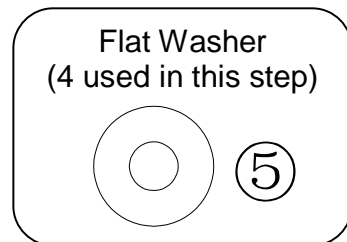
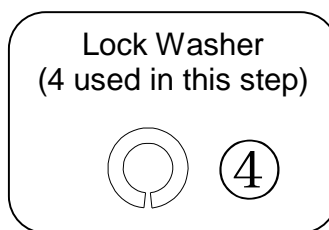
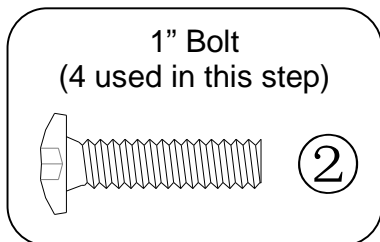
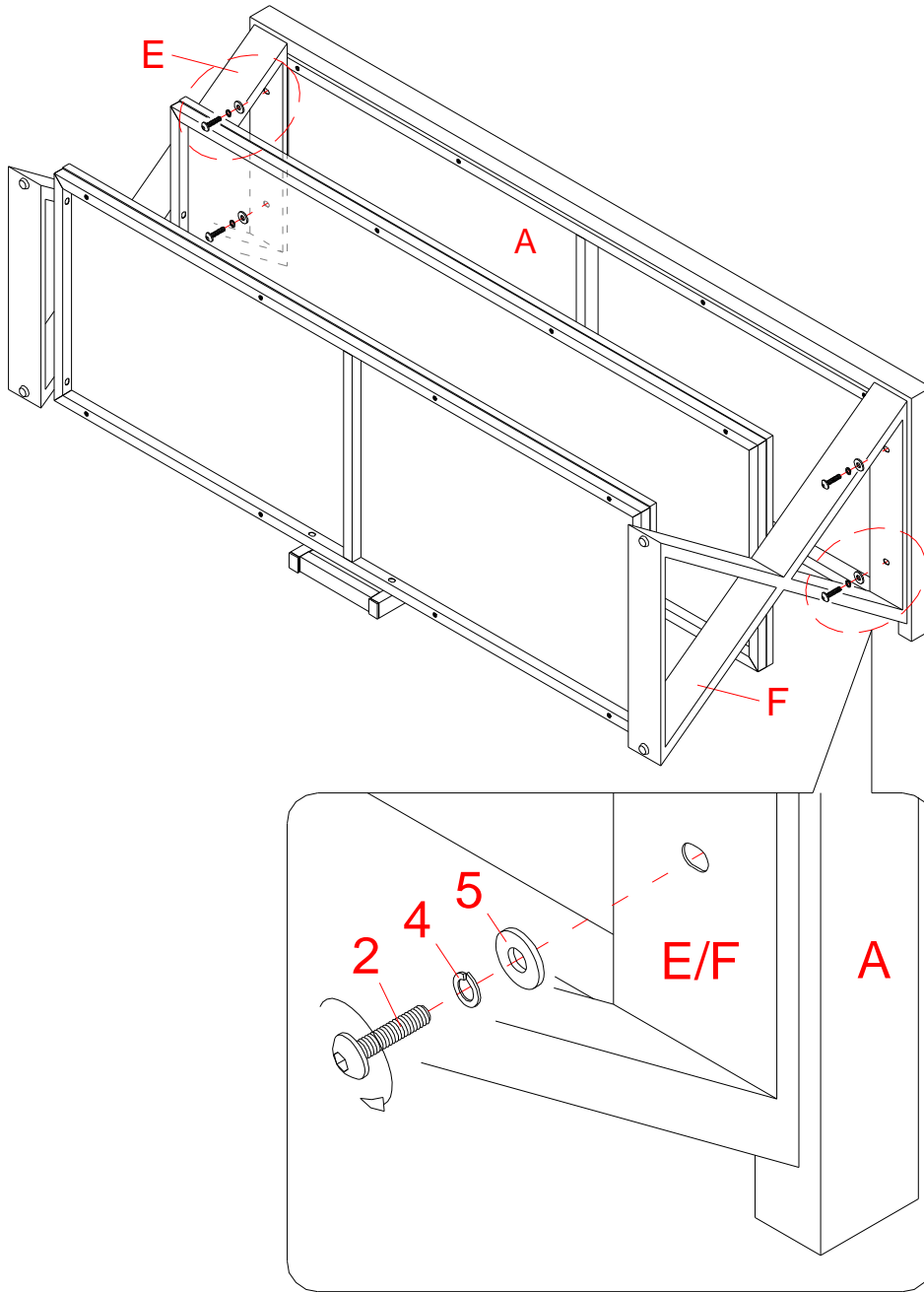

8. Fasten the Top Panel (A) into place with four 1" Bolts (2) and four Washers (4 and 5).



## Assembly Instructions

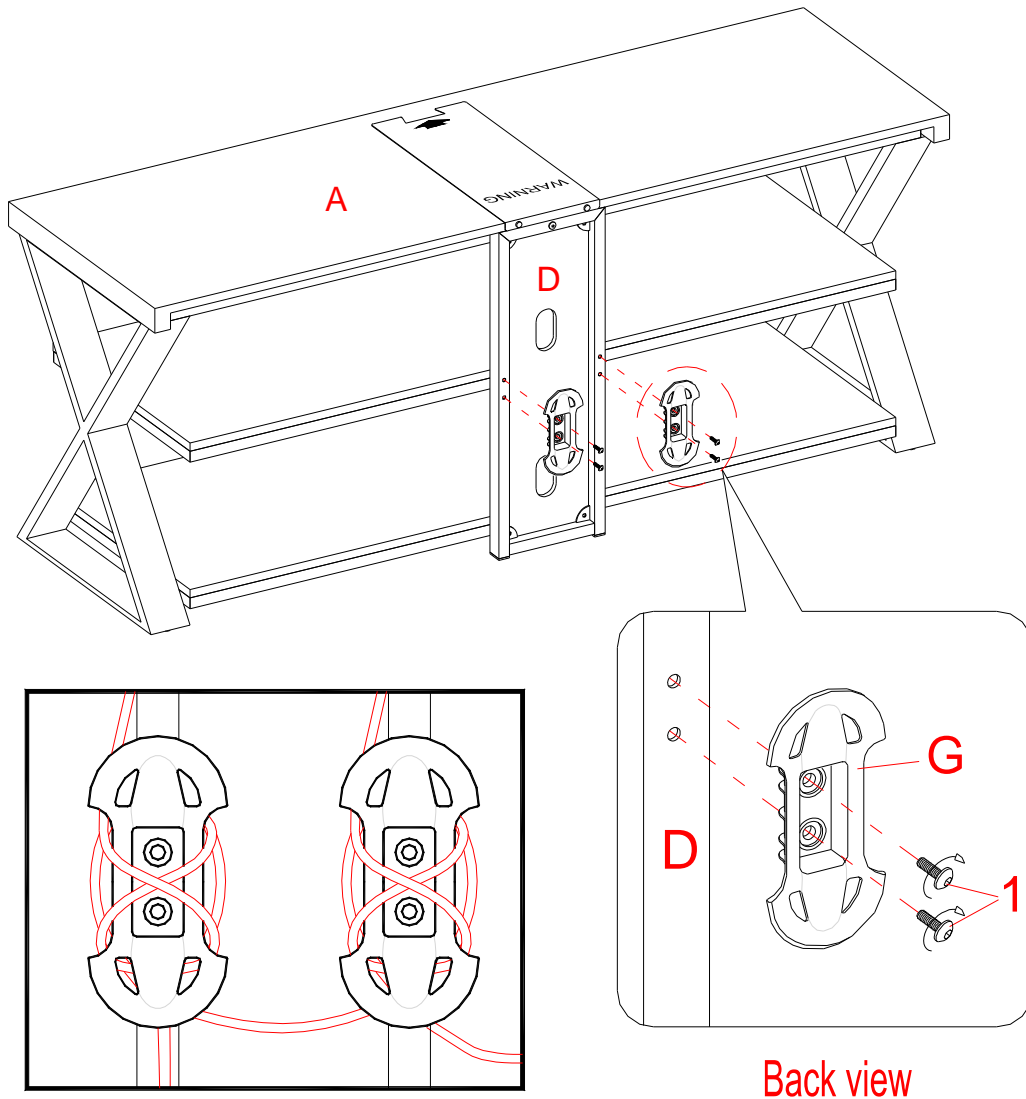

5/8" Bolt  
(4 used in this step)

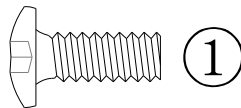

9. Stand the unit upright.
10. Attach 2 Cable Wheels (G) onto the backside of the Back Frame (D) and tighten with the enclosed hex wrench.
11. The cable wheels allow you to organize, route and separate your component cords and cables to minimize tangling and signal interference.

## Assembly Instructions

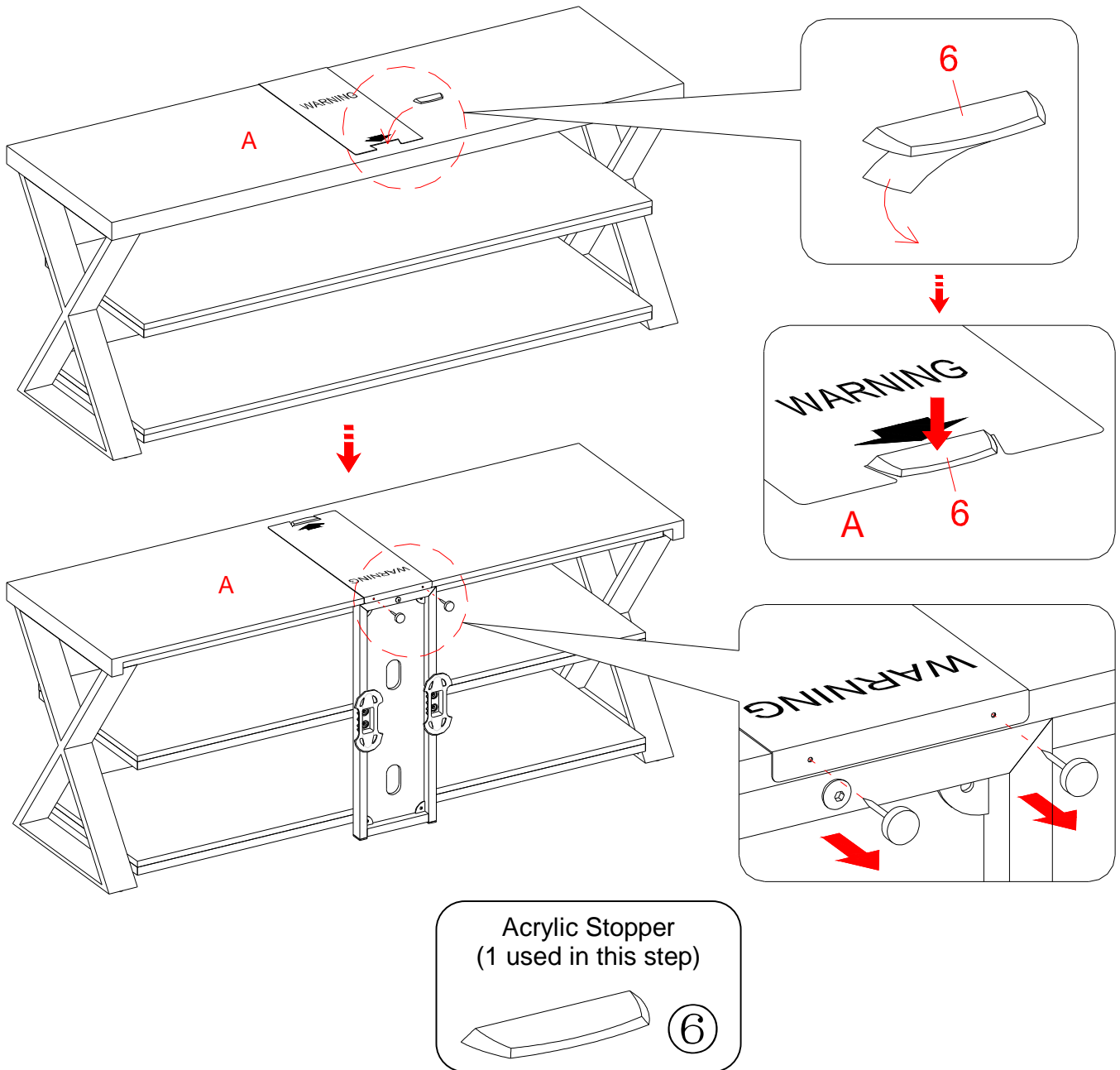

**NOTE:** You must install the Acrylic TV Stopper to prevent the TV from tipping when placing your flat panel television directly on the console.

12. Remove the paper backing from the acrylic stopper (6), then properly align the acrylic stopper into the cut-out on the acrylic stopper template on the top panel (A). Press down on the acrylic stopper to help adhesion.
13. At the back of the Top Panel (A), carefully unscrew two thumb tacks to remove the acrylic stopper template.

## Assembly Instructions

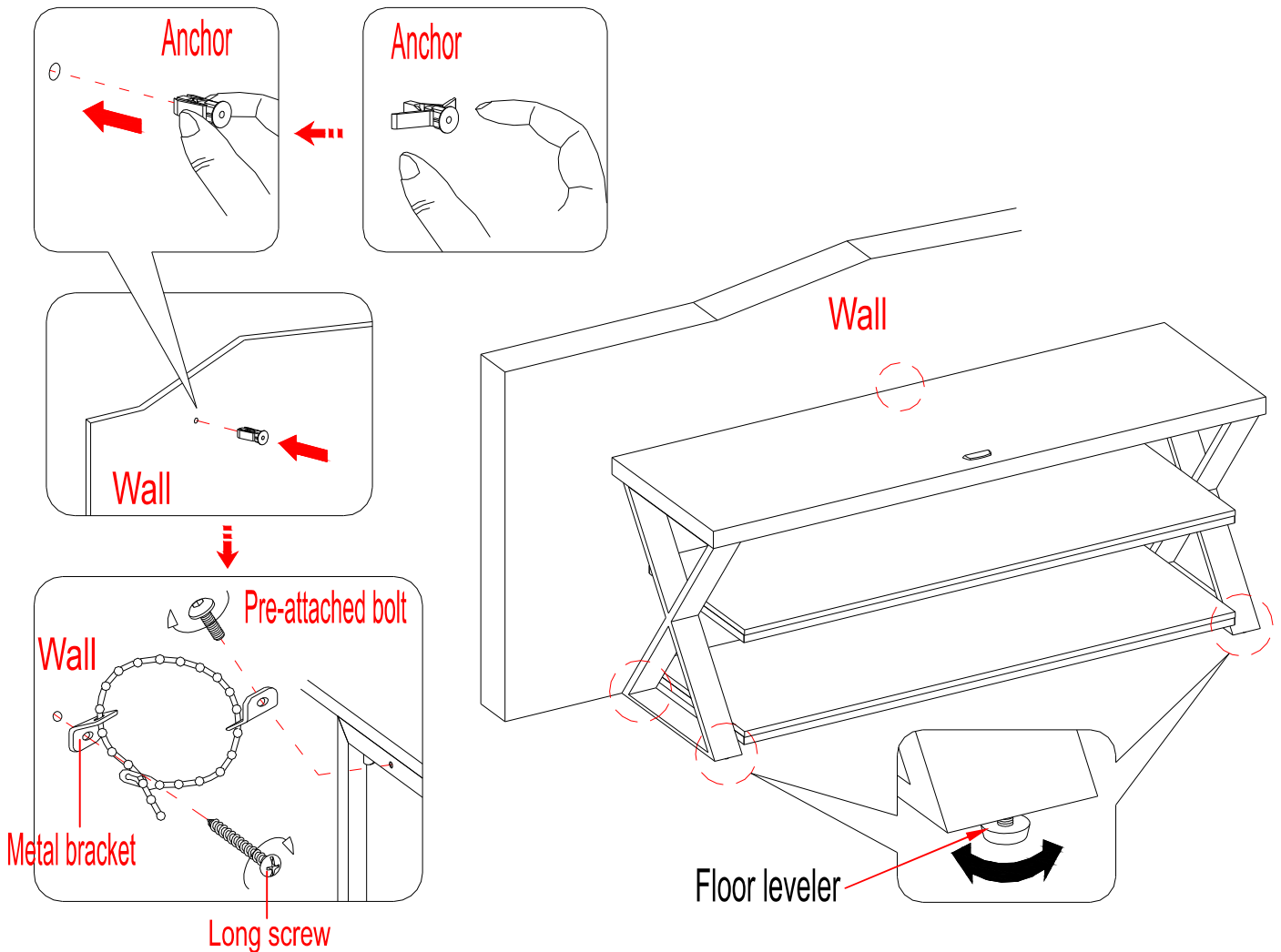

**Tools required:** hex wrench (provided), Phillips screwdriver, mallet, power drill, and 3/8" drill bit.

14. Position the assembled unit at the desired location against a wall. If necessary, adjust the pre-attached Floor Levelers at the bottom of the Legs (E and F) to level the unit. Now, follow the instructions printed on the plastic bag containing the Tipping Restraint Hardware to attach the tip-over restraint to the Back Frame and the wall.

**NOTE:** Young children can be seriously injured by tipping furniture. You must install the Tipping Restraint Hardware with the unit to prevent any accidents or damage to the unit. The tipping restraint is intended only as a deterrent, they are not a substitute for proper adult supervision. The tipping restraint is not an earthquake restraint. If you wish to add the extra security of earthquake restraints, they must be purchased and installed separately.

## Care and Maintenance

- Use a soft, clean cloth that will not scratch the surface when dusting.
- Use of furniture polish is not necessary. Should you choose to use polish, test first in an inconspicuous area.
- Using solvents of any kind on your furniture may damage the finish.
- Never use water to clean your furniture as it may cause damage to the finish.
- Always use coasters under beverage glasses and flowerpots.
- Liquid spills should be removed immediately. Using a soft, clean cloth, blot the spill gently. Avoid rubbing.
- Always use protective pads under hot dishes and plates. Heat can cause chemical changes that may create spotting within the furniture finish.
- Stains or marks from crayons or ink markers will be difficult to remove.
- In the event that your furniture is stained or otherwise damaged during use, we recommend that you call a professional to repair your furniture.
- Check bolts/screws periodically and tighten them if necessary.

## Further Advice about Wood Furniture Care

It is best to keep your furniture in a climate-controlled environment. Extreme temperature and humidity changes can cause fading, warping, shrinking and splitting of wood. It is advised to keep furniture away from direct sunlight as sun may damage the finish.

Proper care and cleaning at home will extend the life of your purchase. Following these important and helpful tips will enhance your furniture as it ages.

**A touch-up pen has been provided to repair any small nicks or scratches that may occur during assembly or shipping.**

We hope you enjoy your purchase for many years.  
Thank you for your purchase!

## QUALITY GUARANTEE

We are confident that you will be delighted with your Whalen Furniture purchase.

Should this product be defective in workmanship or materials or fail under normal use, we will repair or replace it for up to one (1) year from date of purchase. Every Whalen Furniture product is designed to meet your highest expectations. We guarantee that you will immediately see the value of our fine furniture.

This warranty gives you specific legal rights and you may also have other rights which vary from state to state or province to province.

Customer Service: 1-866-942-5362  
8:30 a.m. - 4:30 p.m., PST, Monday to Friday  
[www.whalenfurniture.com](http://www.whalenfurniture.com)