

Lana Modern 3-in-1 TV Stand

Stock # BH47-084-899-01

U.S. Patent 9,215,927

This item is designed to be a 3-in-1 configuration. Please choose the option that best suits your needs. DO NOT discard any of the hardware or parts that you will not use on your chosen option. This will allow you to use this TV Stand in different configurations at a later date, if desired.

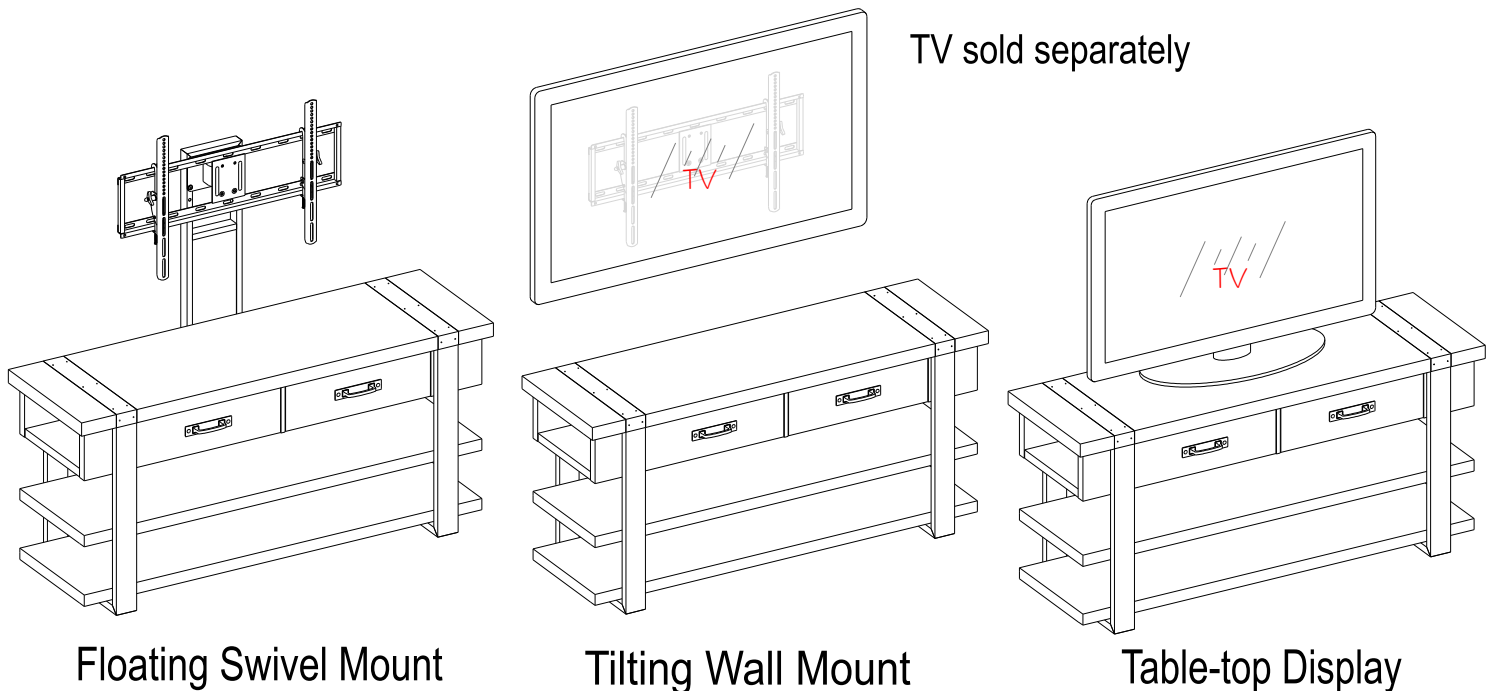

ADULT ASSEMBLY REQUIRED

If you have any questions regarding assembly or if parts are missing, DO NOT return this item to the store where it was purchased. Please call our toll-free customer service number and have your instructions and parts list ready to provide the model name, part name or factory number:

866-942-5362

Pacific Standard Time: 8:30 a.m. - 4:30 p.m., Monday - Friday

Or visit our web site 24 hours a day, 7 days a week for product assistance at

www.whalenstyle.com

Or e-mail your request to parts@whalenfurniture.com

THIS INSTRUCTION BOOKLET CONTAINS **IMPORTANT** SAFETY INFORMATION.
PLEASE READ AND KEEP FOR FUTURE REFERENCE.

Date 2018-08-20

Rev. 0001-B

MAXIMUM RECOMMENDED WEIGHT LOADS

MANUFACTURER: Whalen Furniture Manufacturing
CATALOG: Lana Modern 3-in-1 TV Stand
MODEL # BH47-084-899-01
MADE IN CHINA

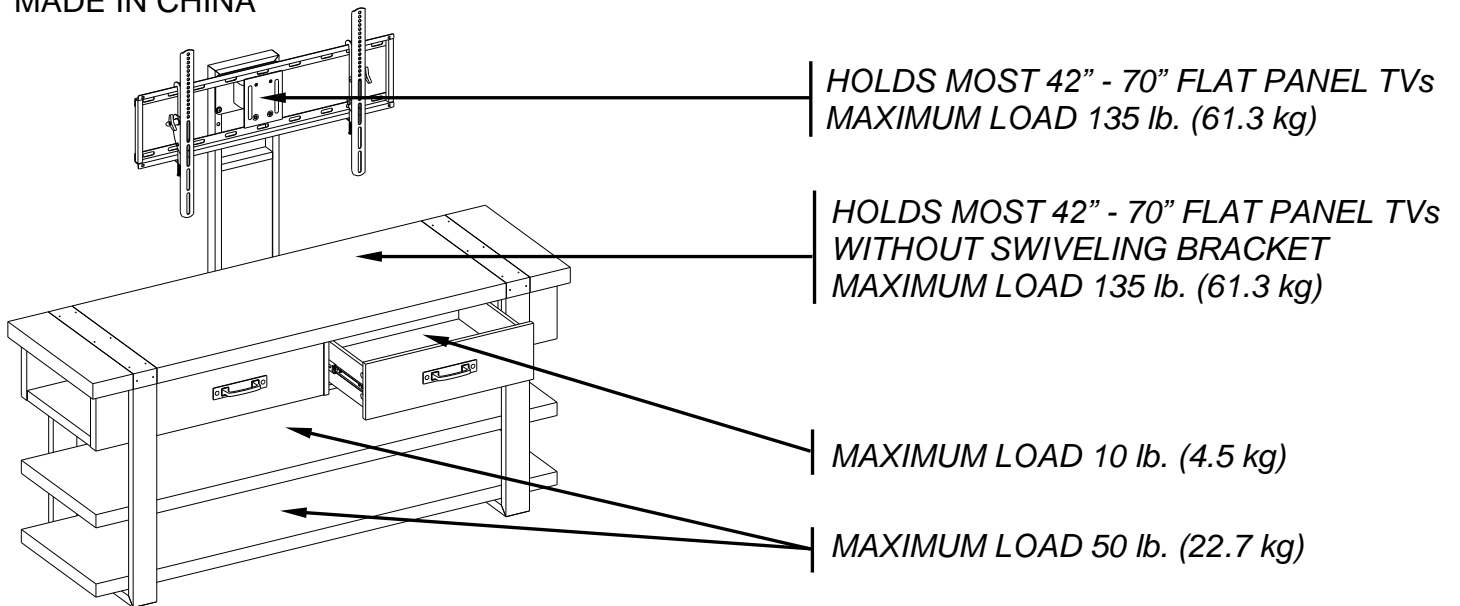

WARNING

THIS UNIT IS NOT INTENDED FOR USE WITH CRT TVS. USE ONLY WITH FLAT PANEL TVS AND AUDIO/VIDEO EQUIPMENT MEETING RECOMMENDED SIZE AND WEIGHT LIMITS. NEVER USE WITH LARGER/HEAVIER THAN RECOMMENDED FLAT PANEL TVS OR EQUIPMENT. TO AVOID INSTABILITY, PLACE FLAT PANEL TV IN THE CENTRE OF THE UNIT; THE BASE OF THE TELEVISION MUST BE ABLE TO REST ON THE SUPPORTING SURFACE OF THE UNIT WITHOUT OVER-HANGING THE EDGES. IMPROPERLY POSITIONED FLAT PANEL TVS, OR FLAT PANEL TVS OR OTHER EQUIPMENT THAT EXCEED RECOMMENDED SIZE AND WEIGHT LIMITS COULD FALL OFF OR BREAK THE UNIT, CAUSING POSSIBLE SERIOUS INJURY.

GENERAL INFORMATION, TIPS and TRICKS

1. Please read the Assembly Instructions prior to assembling this product.
2. Remove all hardware from the box and sort by size.
3. Check to see that all hardware and parts are present BEFORE assembling.
4. Ask a friend to assist you with the assembly of this furniture.
5. To avoid damage, assemble the product on a sturdy, level and protective surface.
6. Please wait until all steps are completed before fully tightening bolts.
7. Make sure all bolts are tightly fastened before the unit is used.

This product is sold with one set of Tipping Restraint Hardware Kit. You must install the Tipping Restraint Hardware between the wall and the TV Stand to prevent any accidents or damages. When properly installed, this restraint can provide protection against the unexpected tipping of the unit due to small tremors, bumps or climbing. The restraint is only a deterrent and is not a substitute for proper adult supervision. Use of tip-over restraints may only reduce, but not eliminate, the risk of tip-over.

IMPORTANT

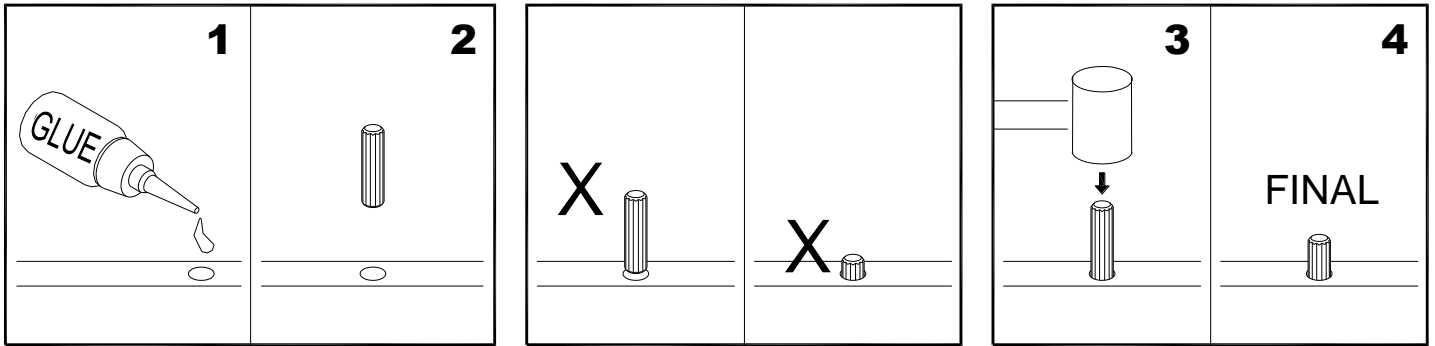

Before you begin: Open, identify and count all parts prior to assembly. Lay out parts on a flat and non-abrasive surface. You will need the parts identified on page 4, 5 and 6 of this instruction manual.

NOTE: IT IS VERY IMPORTANT TO USE GLUE WITH DOWELS. EXCESS GLUE CAN BE WIPED OFF WITH DAMP CLOTH.

Insert the Dowel at least half way by tapping lightly with a rubber mallet, IF NECESSARY.

CAM LOCK SYSTEM OPERATION

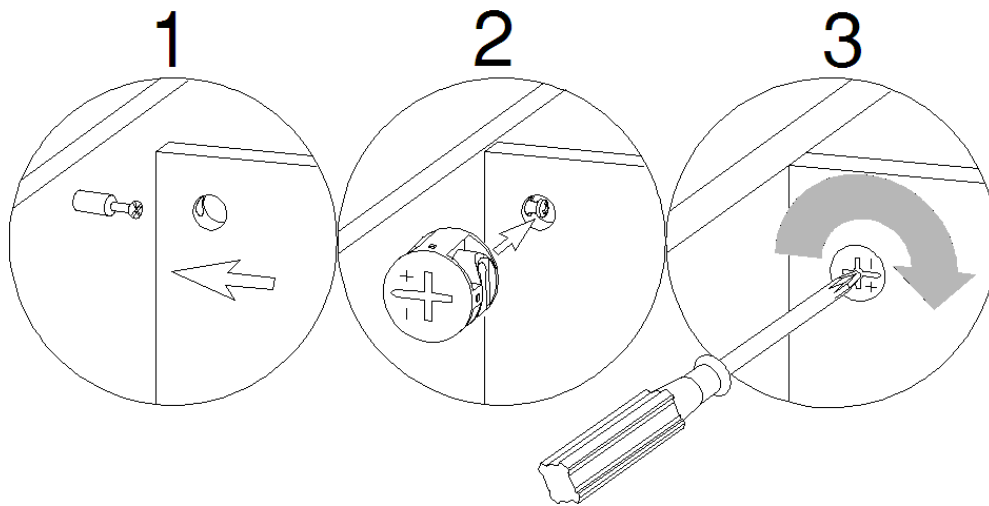

HOW THE KNOCK DOWN (KD) ASSEMBLY SYSTEM WORKS

1. Screw the Cam Bolt into the threaded inserts on the panel. Connect both panels together; making sure Cam Bolt goes into the pre-drilled hole on the end of panel for Cam Lock.
2. Insert the Cam Lock into the pre-drilled large hole on the panel. Make sure the arrow on the face of Cam Lock faces out and points towards Cam Bolt.
3. Take a Phillips screwdriver and rotate the Cam Lock clockwise to lock the Cam Bolt in place.

You are now ready to assemble the KD unit.

Parts and Hardware List

Please read completely through the instructions and verify that all listed parts and hardware are present before beginning assembly.

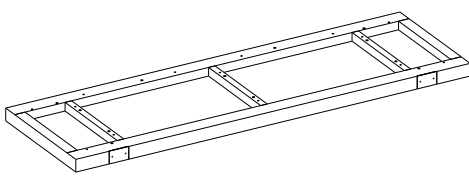

A- Top Panel
(Qty. 1)

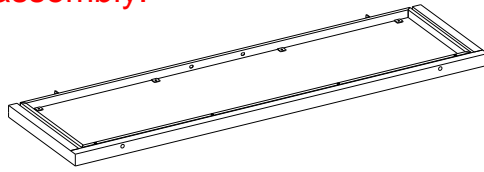

B- Lower Shelf with Metal Frame
(Qty. 2)

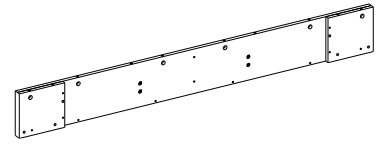

C- Drawer Box Back Panel
(Qty. 1)

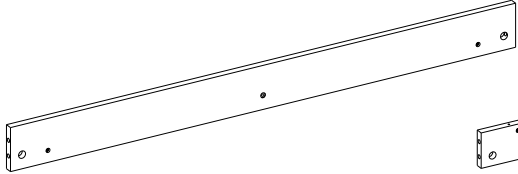

D- Front Stretcher (Qty. 1)

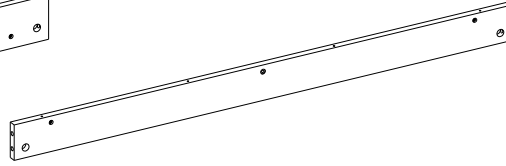

E- Back Stretcher (Qty. 1)

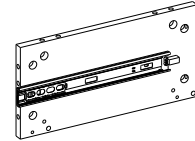

F- Drawer Box Left Side (Qty. 1)

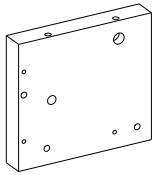

G- Drawer Box Left Front
(Qty. 1)

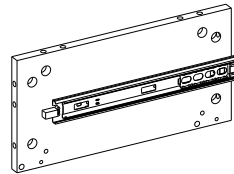

H- Drawer Box Right Side
(Qty. 1)

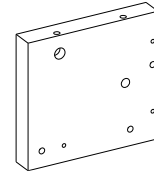

I- Drawer Box Right Front
(Qty. 1)

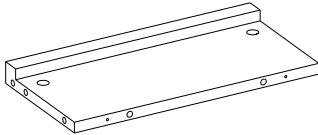

J- Fixed Shelf (Qty. 2)

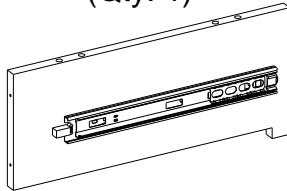

K- Partition Panel (Qty. 1)

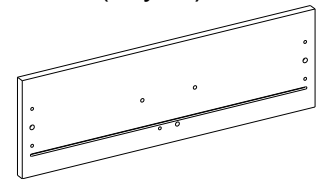

L- Drawer Front (Qty. 2)

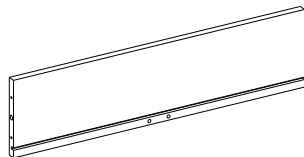

M- Drawer Back Panel (Qty. 2)

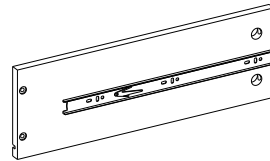

N- Drawer Left Side (Qty. 2)

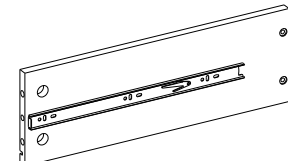

O- Drawer Right Side (Qty. 2)

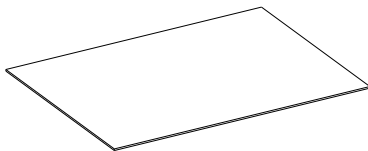

P- Drawer Bottom Panel (Qty. 2)

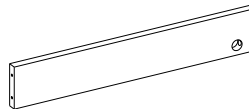

Q- Drawer Bottom Support (Qty. 2)

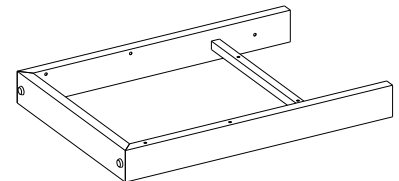

R- Left Leg (Qty. 1)

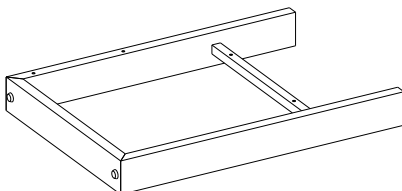

S- Right Leg (Qty. 1)

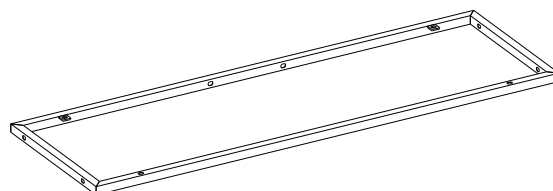

T- Top Metal Frame (Qty. 1)

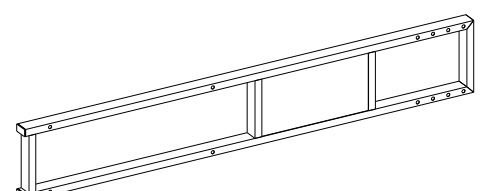

U- Floater Post (Qty. 1)

Parts and Hardware List

Please read completely through the instructions and verify that all listed parts and hardware are present before beginning assembly.

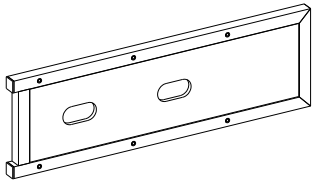

V- Back Frame (Qty. 1)

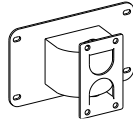

W- Swiveling Bracket (Qty. 1)

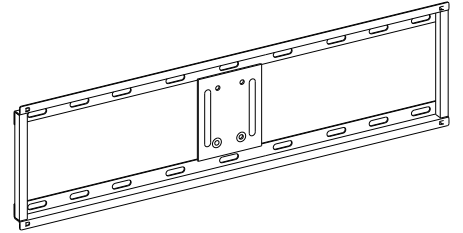

X- Mounting Frame (Qty. 1)

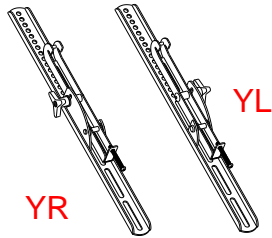

Y- Monitor Bracket (Qty. 2)

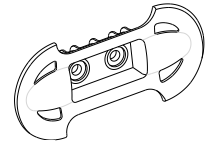

Z- Cable Wheel (Qty. 2)



(1) Small Cam Lock
(Qty. 10+1 extra)



(2) Large Cam Lock
(Qty. 30+1 extra)

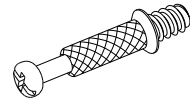

(3) Cam Bolt
(Qty. 40+2 extra)

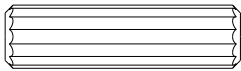

(4) M8 x 30 mm Wood Dowel
(Qty. 34+1 extra)



(5) M6 x 30 mm Wood Dowel
(Qty. 10+1 extra)

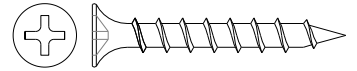

(6) M4 x 32 mm Screw
(Qty. 24+1 extra)

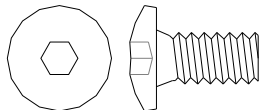

(7) 1/2" Bolt (Qty. 4+1 extra)

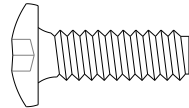

(8) 3/4" Bolt (Qty. 10+1 extra)

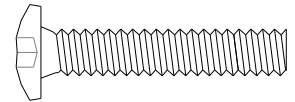

(9) 1-1/4" Bolt (Qty. 12+1 extra)

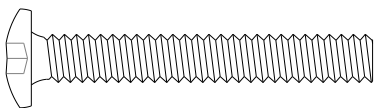

(10) 1-3/4" Bolt (Qty. 2+1 extra)

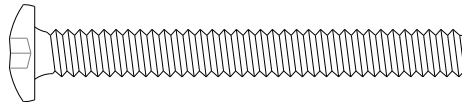

(11) 2-1/4" Bolt (Qty. 8+1 extra)



(12) Hex Nut (Qty. 4+1 extra)



(13) Lock Washer
(Qty. 40+2 extra)

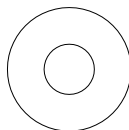

(14) Flat Washer
(Qty. 40+2 extra)

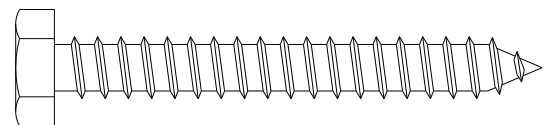

(15) 2-1/2" Lag Bolt
(Qty. 4)

Parts and Hardware List

Please read completely through the instructions and verify that all listed parts and hardware are present before beginning assembly.

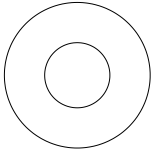

(16) Large Flat Washer
(Qty. 4+1 extra)

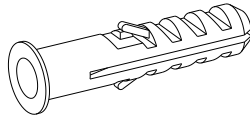

(17) Concrete Anchor
(Qty. 4)

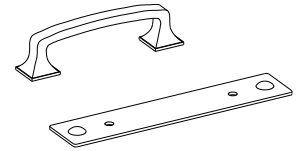

(18) Handle and Back Plate
(Qty. 2)

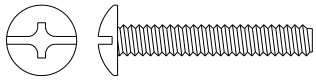

(19) Handle Bolt
(Qty. 4)

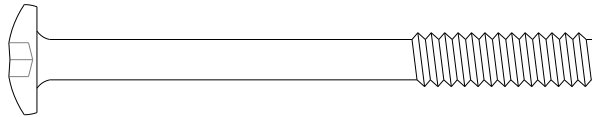

(20) 2-5/8" Bolt
(Qty. 4+1 extra)

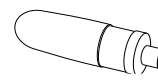

Glue
(Qty. 1)

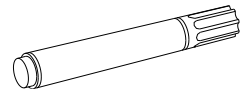

Touch-up Pen
(Qty. 1)



Open Wrench
(Qty. 1)

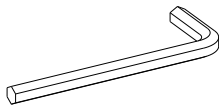

4 mm Hex Wrench
(Qty. 1)

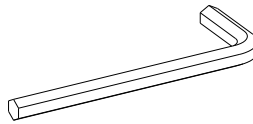

3/16" Hex Wrench
(Qty. 1)

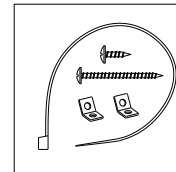

Tipping Restraint Hardware Kit (Qty. 1)
(Inside Plastic Bag)

TV Mounting Kit

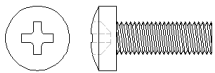

M4 x 12 mm Bolt (4)



M4 x 30 mm Bolt (4)

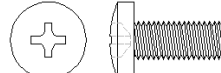

M5 x 12 mm Bolt (4)

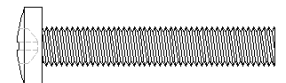

M5 x 30 mm Bolt (4)

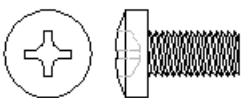

M6 x 12 mm Bolt (4)



M6 x 35 mm Bolt (4)

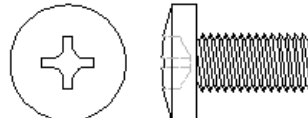

M8 x 16 mm Bolt (4)

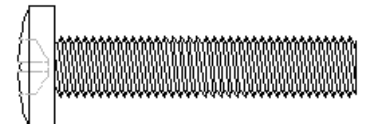

M8 x 40 mm Bolt mm (4)



M4 Lock Washer (4)



M5 Lock Washer (4)



M6 Lock Washer (4)

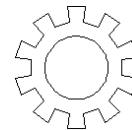

M8 Lock Washer (4)



Large Spacer (4)



Small Spacer (4)

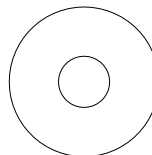

M4/M5 Flat Washer (8)

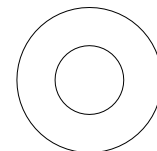

M6/M8 Flat Washer (4)

Tools required: Hex wrench, open wrench (provided) and Phillips screwdriver (not provided).

Drawer Assembling

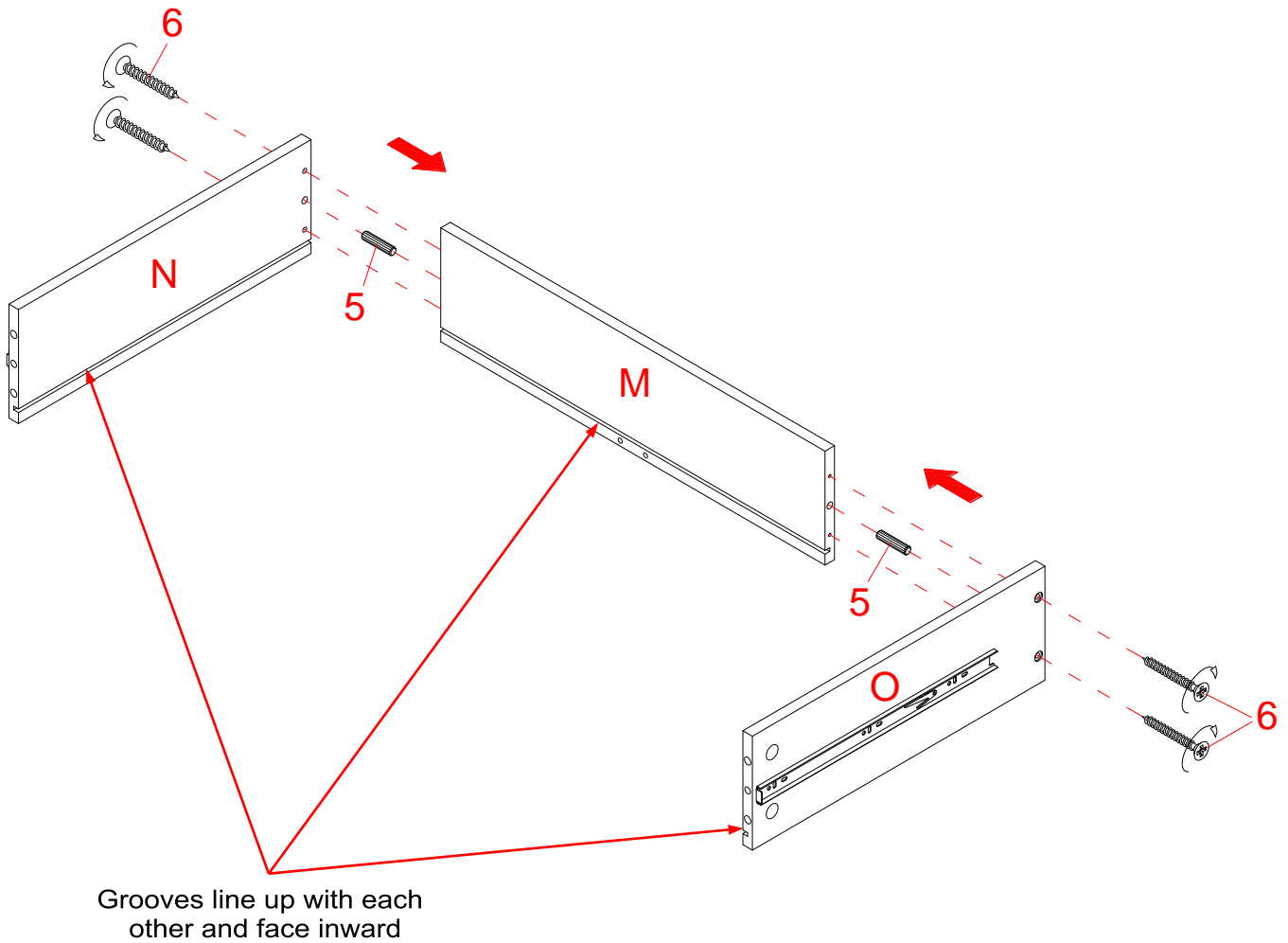

M6 x 30 mm Wood Dowel
(2 used in this step)



⑤

M4 x 32 mm Screw
(4 used in this step)

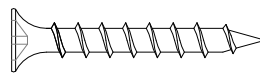

⑥

1. Unpack the unit and confirm that you have all the hardware and required parts.
2. Fasten one Drawer Back Panel (M) between the Drawer Left and Right Side Panels (N and O) with four 32 mm Screws (6) and two M6 x 30 mm Wood Dowels (5).
NOTE: It is very important to use a small amount of glue on both ends of dowels.

Drawer Assembling

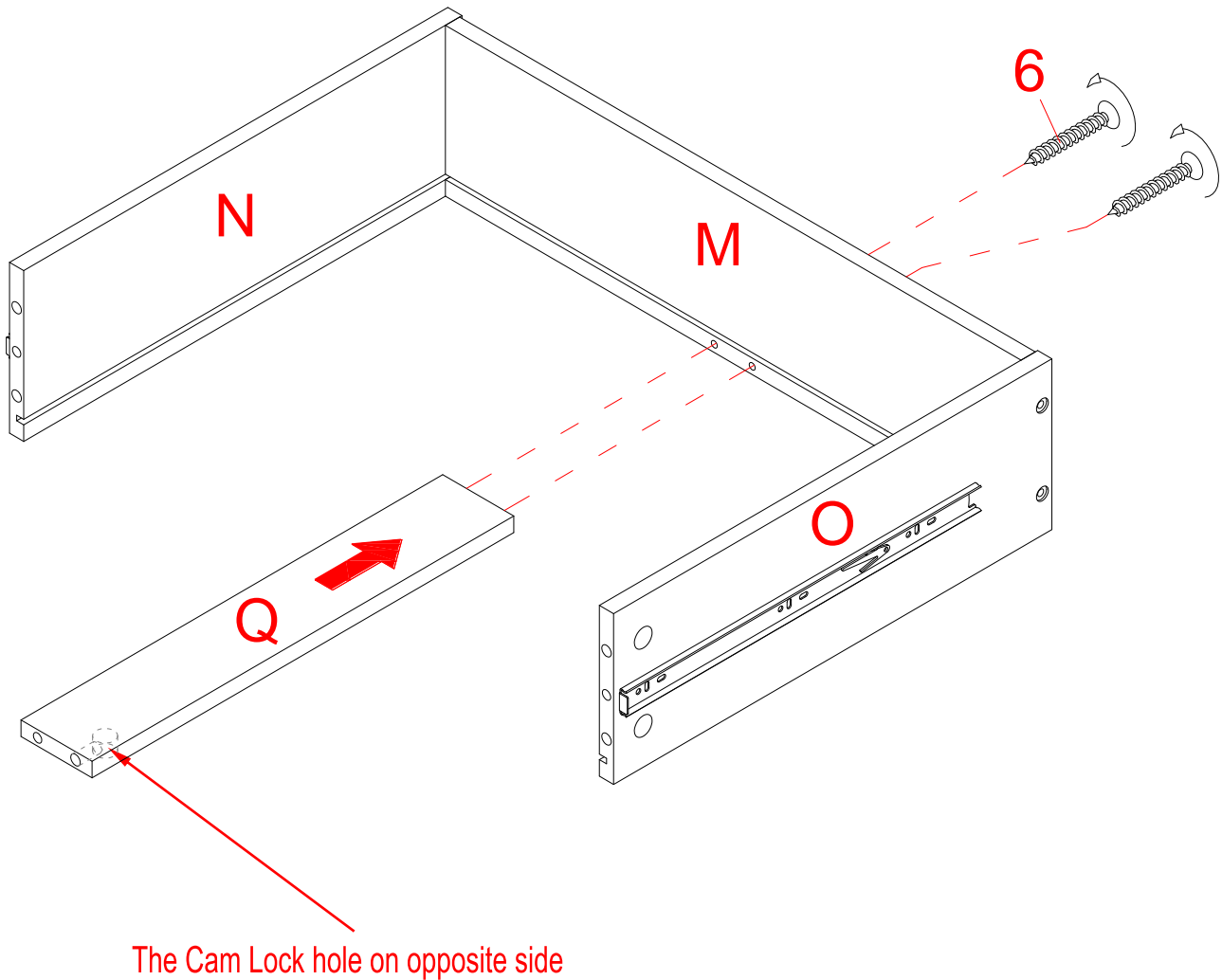

The Cam Lock hole on opposite side

M4 x 32 mm Screw
(2 used in this step)

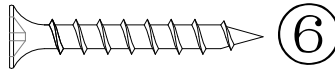

3. Fasten one Drawer Bottom Support (Q) to the Drawer Back Panel (M) with two 32 mm Screws (6).

Drawer Assembling

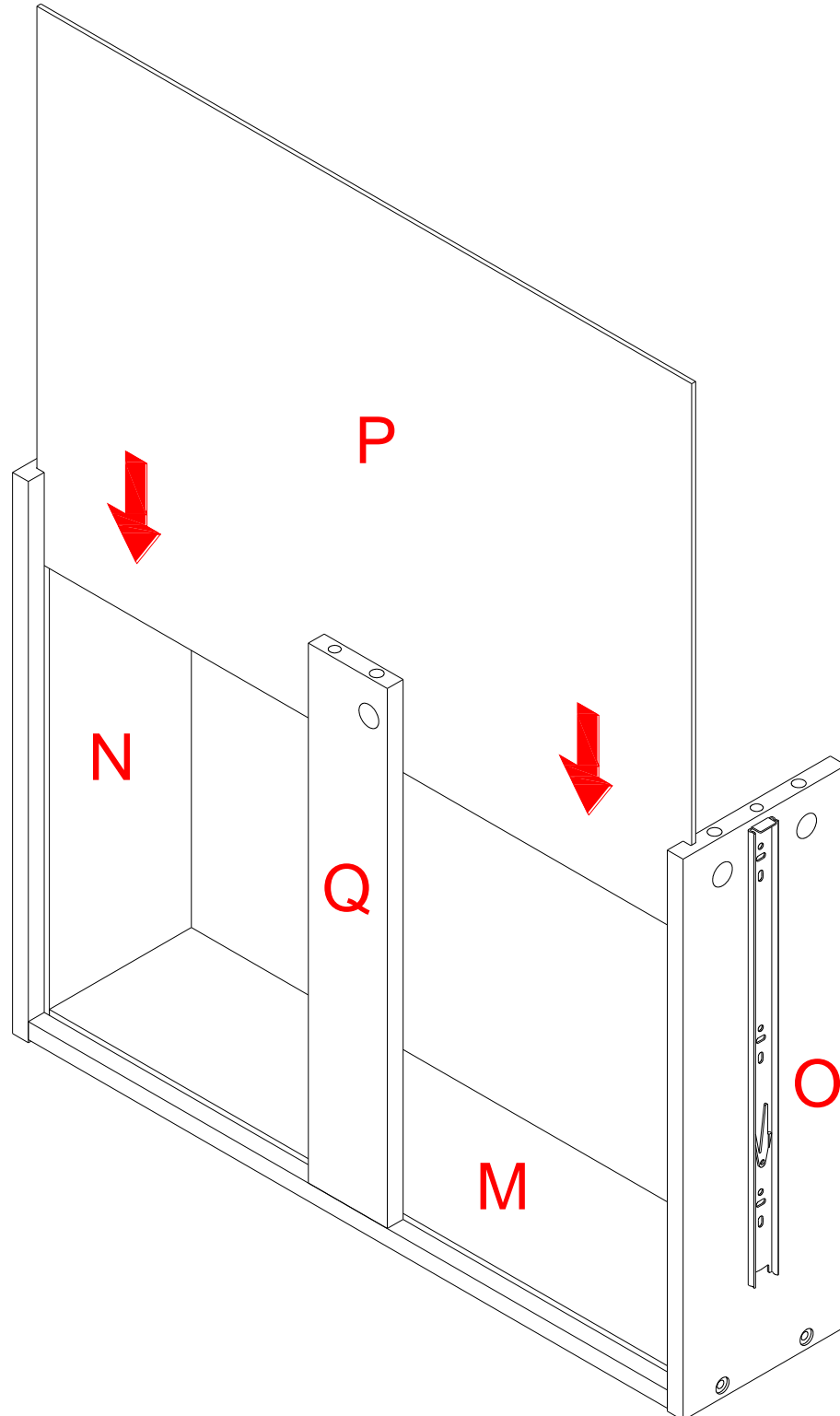

4. Slide one Drawer Bottom Panel (P) into the grooves between the Drawer Left and Right Side Panels (N and O) until fully inserted into the groove of the Drawer Back Panel (M).

Drawer Assembling

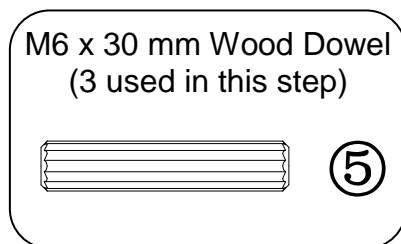
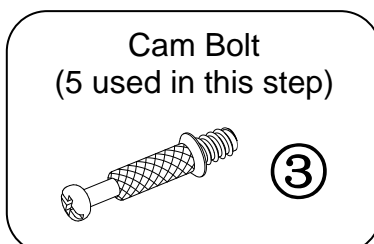
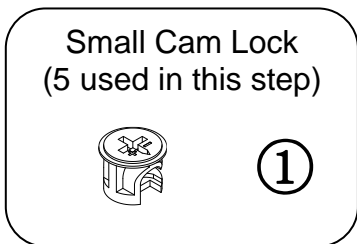
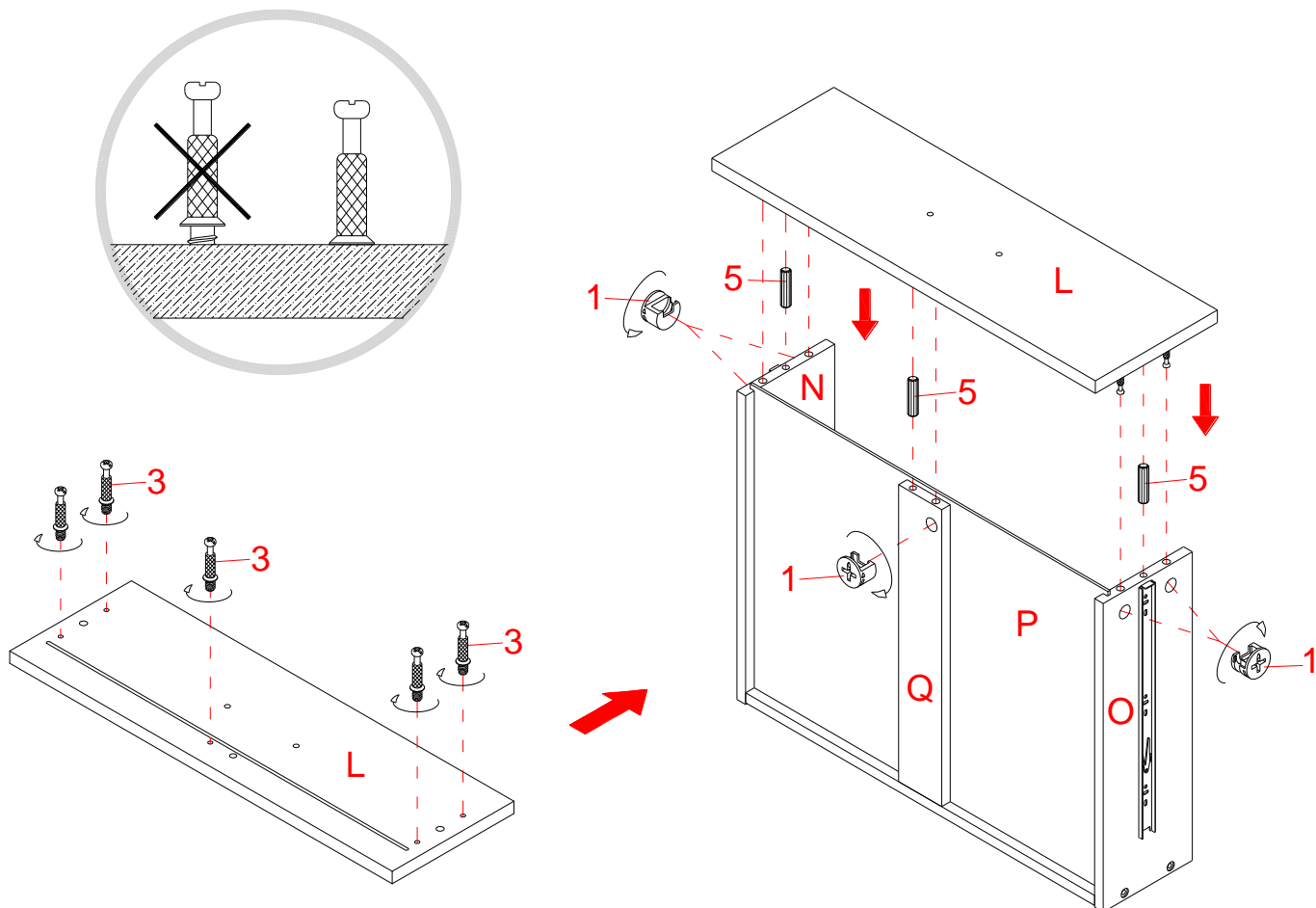

5. Securely screw five Cam Bolts (3) into the designated small holes on one Drawer Front (L).
6. Fasten the Drawer Front (L) to the Drawer Left and Right Side Panels (N and O) and the Drawer Bottom Support (Q) with three M6 x 30 mm Wood Dowels (5) and five Small Cam Locks (1) (Refer to page 3 on Cam Lock system operation supplement). Make sure that the Drawer Bottom Panel (P) fits securely into the groove of the Drawer Front (L).

Drawer Assembling

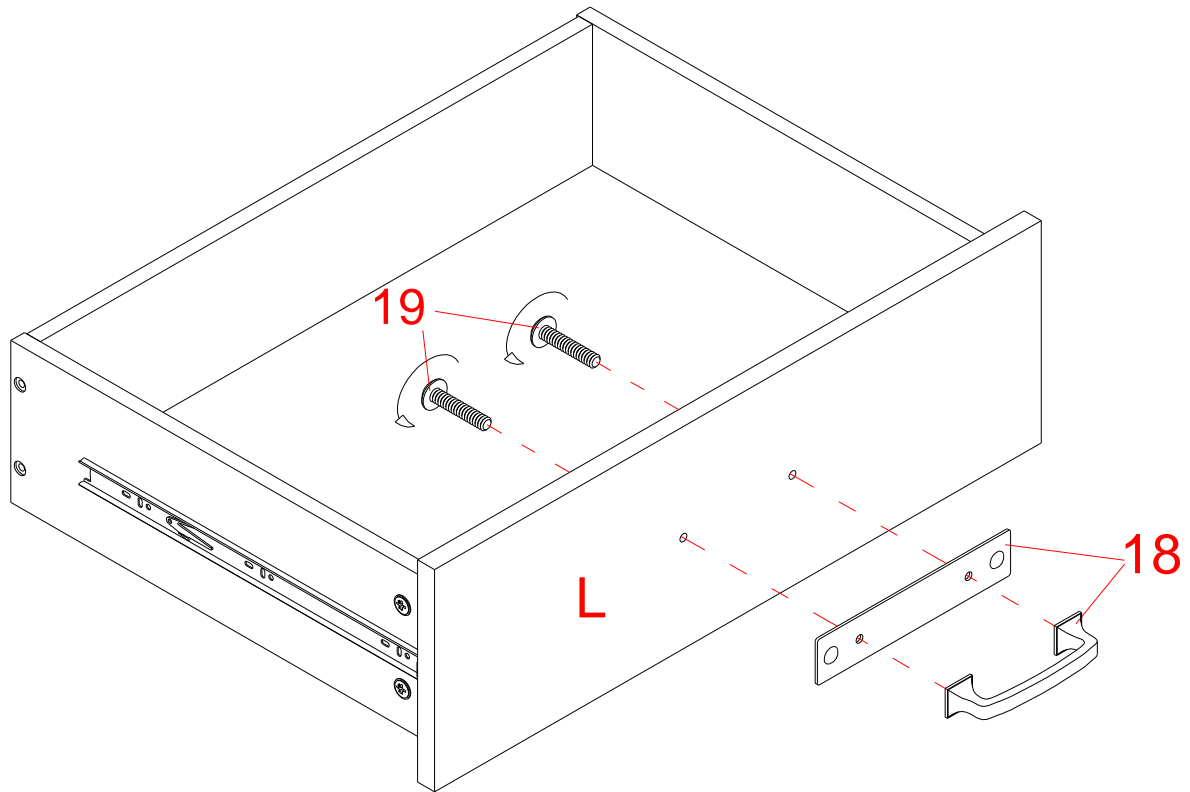

Handle and Back Plate
(1 used in this step)

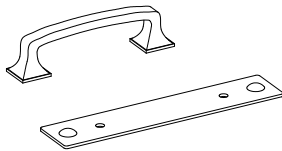

Handle Bolt
(2 used in this step)

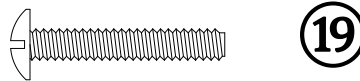

7. Turn the assembled drawer upright. Attach one Handle and one Back Plate (18) to the front side of the Drawer Front (L) with the provided Handle Bolts (19).
8. Repeat the same process to assemble the other drawer.

Assembly Instructions

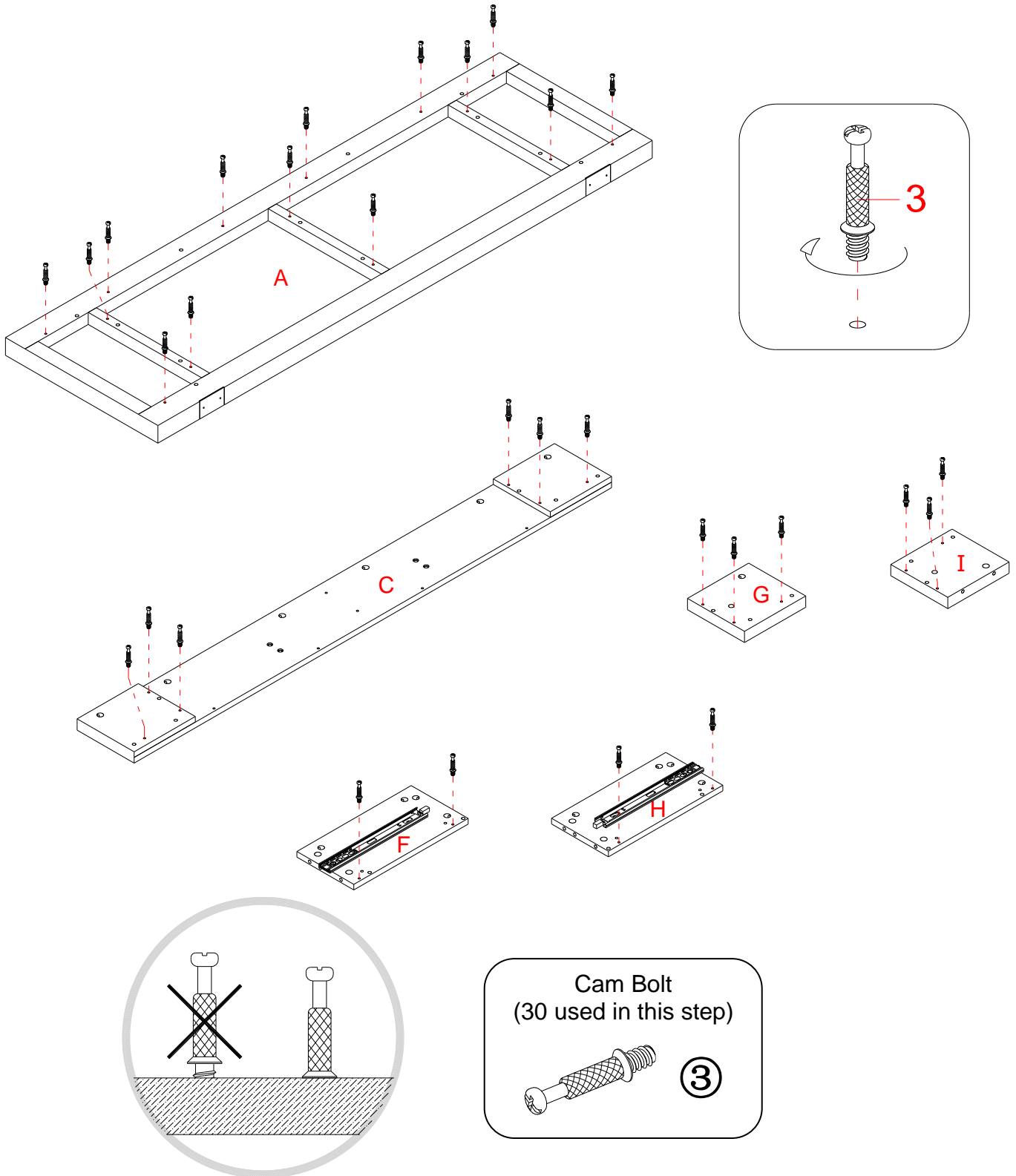

- Securely screw the Cam Bolts (3) into the designated small holes on the Top Panel (A), Back Panel (C), Drawer Box Side Panels (F and H) and Drawer Box Front Panels (G and I) using a Phillips screwdriver.

Assembly Instructions

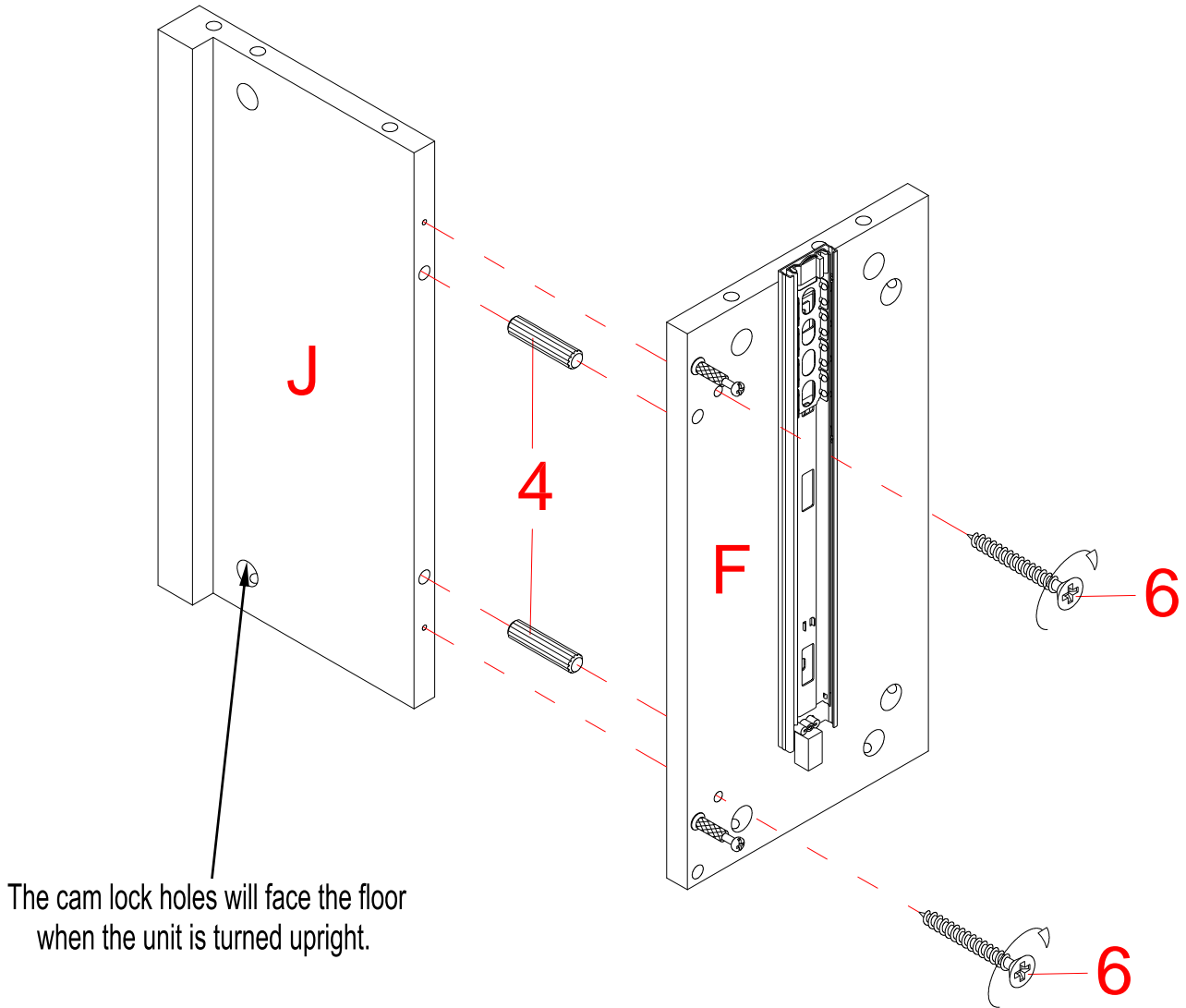

M8 x 30 mm Wood Dowel
(2 used in this step)

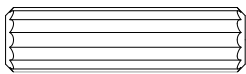

④

M4 x 32 mm Screw
(2 used in this step)

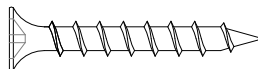

⑥

10. Attach one Fixed Shelf (J) to the Drawer Box Left Side Panel (F) with two M8 x 30 mm Wood Dowels (4) and two 32 mm Screws (6).

Assembly Instructions

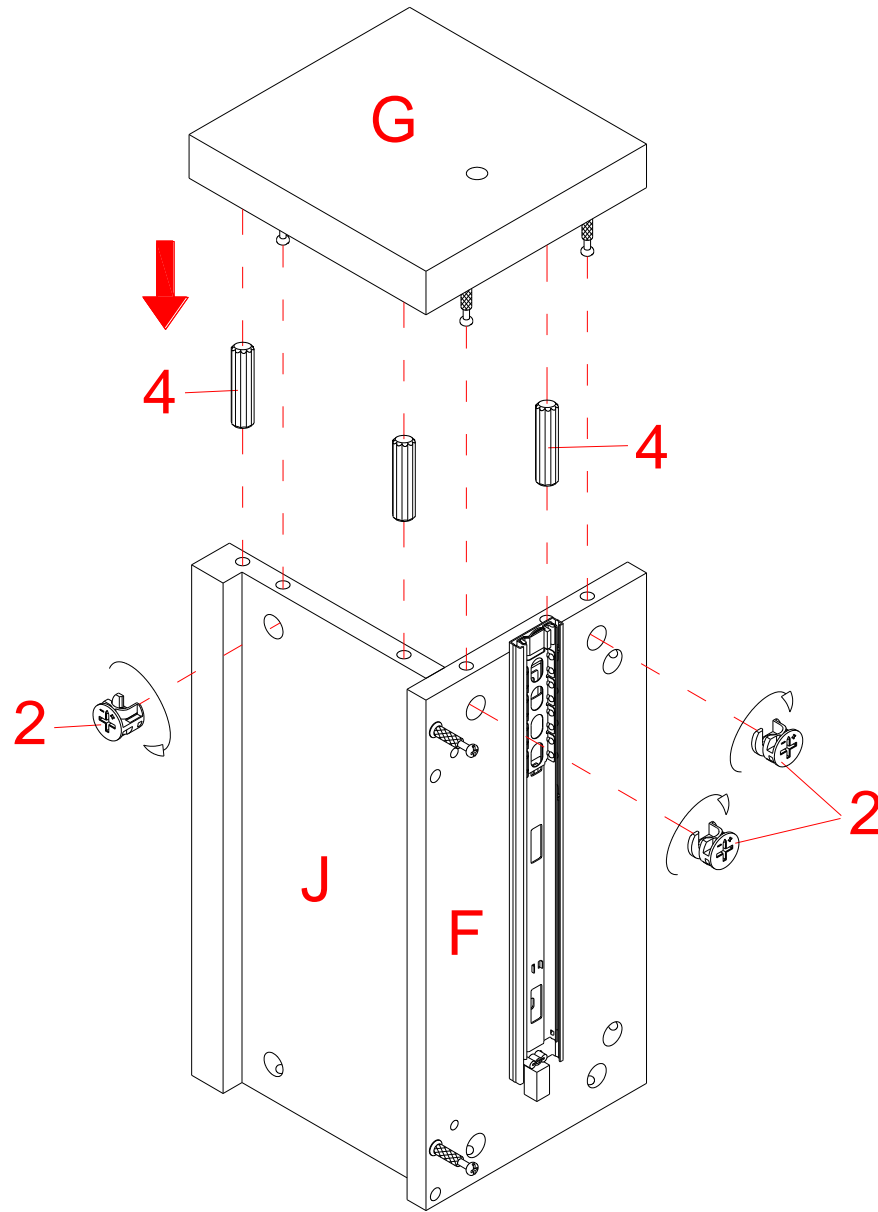

Large Cam Lock
(3 used in this step)



②

M8 x 30 mm Wood Dowel
(3 used in this step)

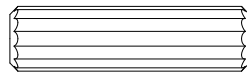

④

11. Attach the Drawer Box Left Front (G) to the Fixed Shelf (J) and the Drawer Box Left Side Panel (F) with three Large Cam Locks (2) and three M8 x 30 mm Wood Dowels (4).

Assembly Instructions

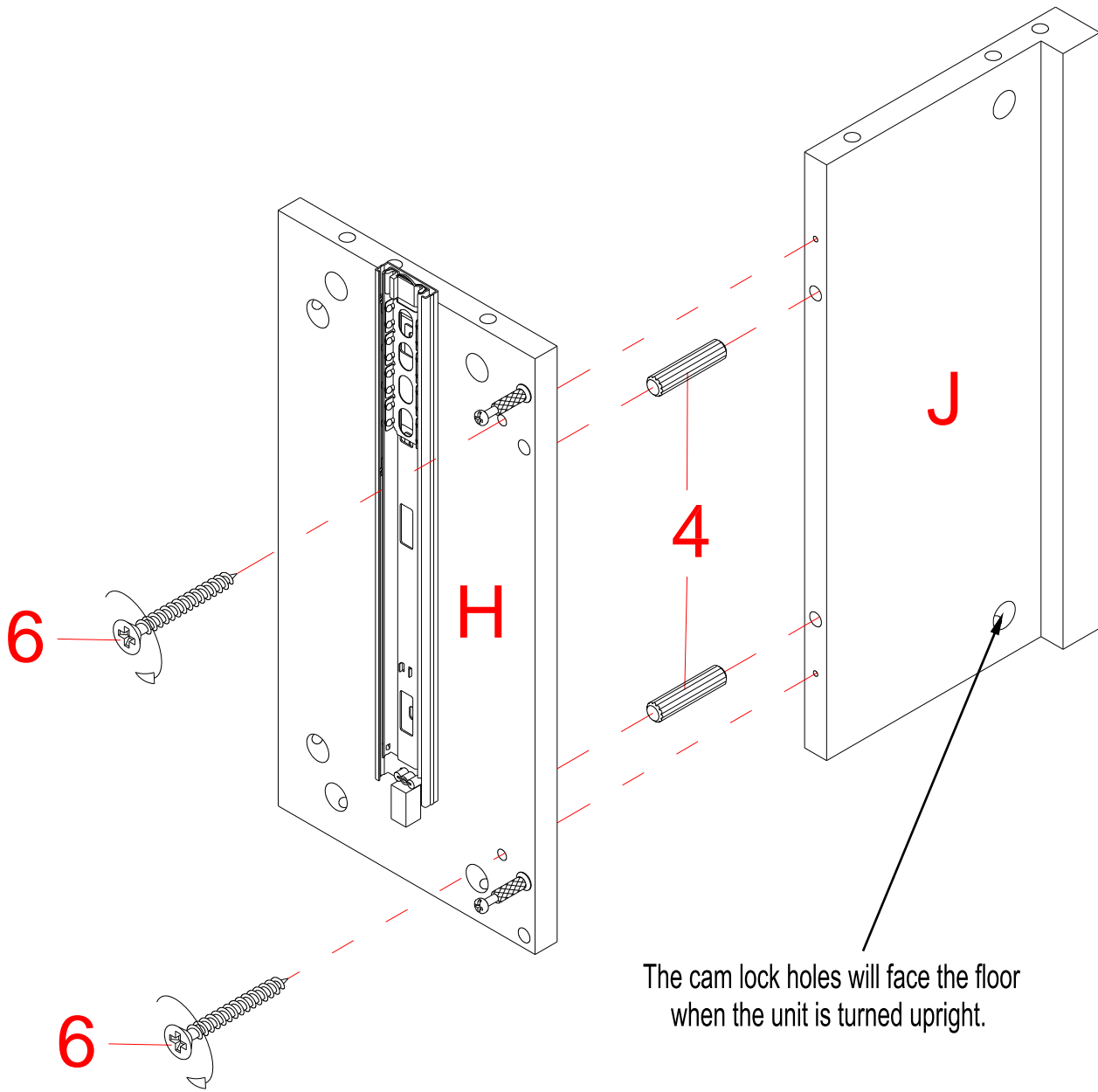

M8 x 30 mm Wood Dowel
(2 used in this step)

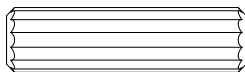

④

M4 x 32 mm Screw
(2 used in this step)

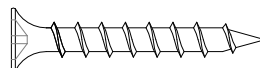

⑥

12. Attach the other Fixed Shelf (J) to the Drawer Box Right Side Panel (H) with two M8 x 30 mm Wood Dowels (4) and two 32 mm Screws (6).

Assembly Instructions

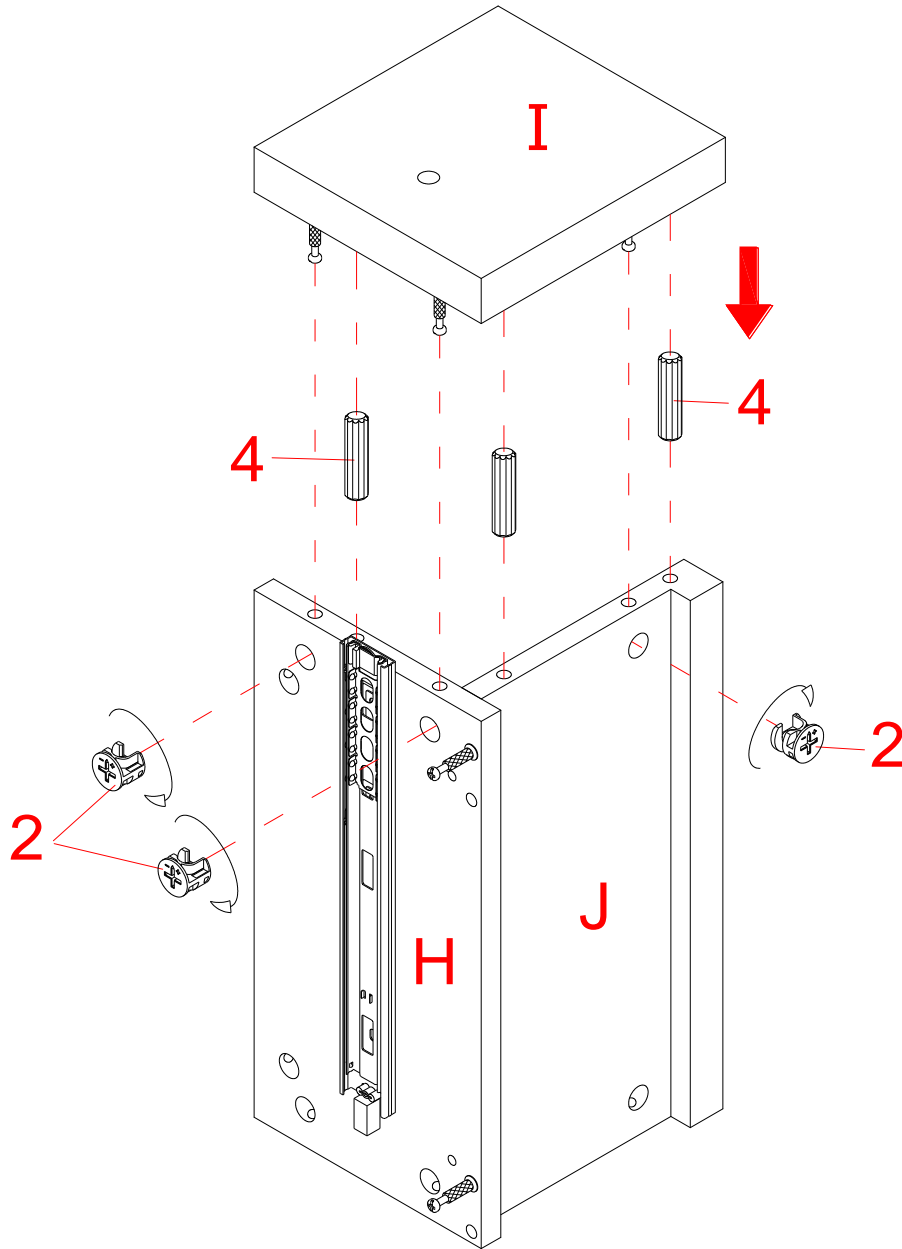

Large Cam Lock
(3 used in this step)



②

M8 x 30 mm Wood Dowel
(3 used in this step)

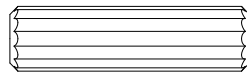

④

13. Attach the Drawer Box Right Front (I) to the Fixed Shelf (J) and the Drawer Box Right Side Panel (H) with three Large Cam Locks (2) and three M8 x 30 mm Wood Dowels (4).

Assembly Instructions

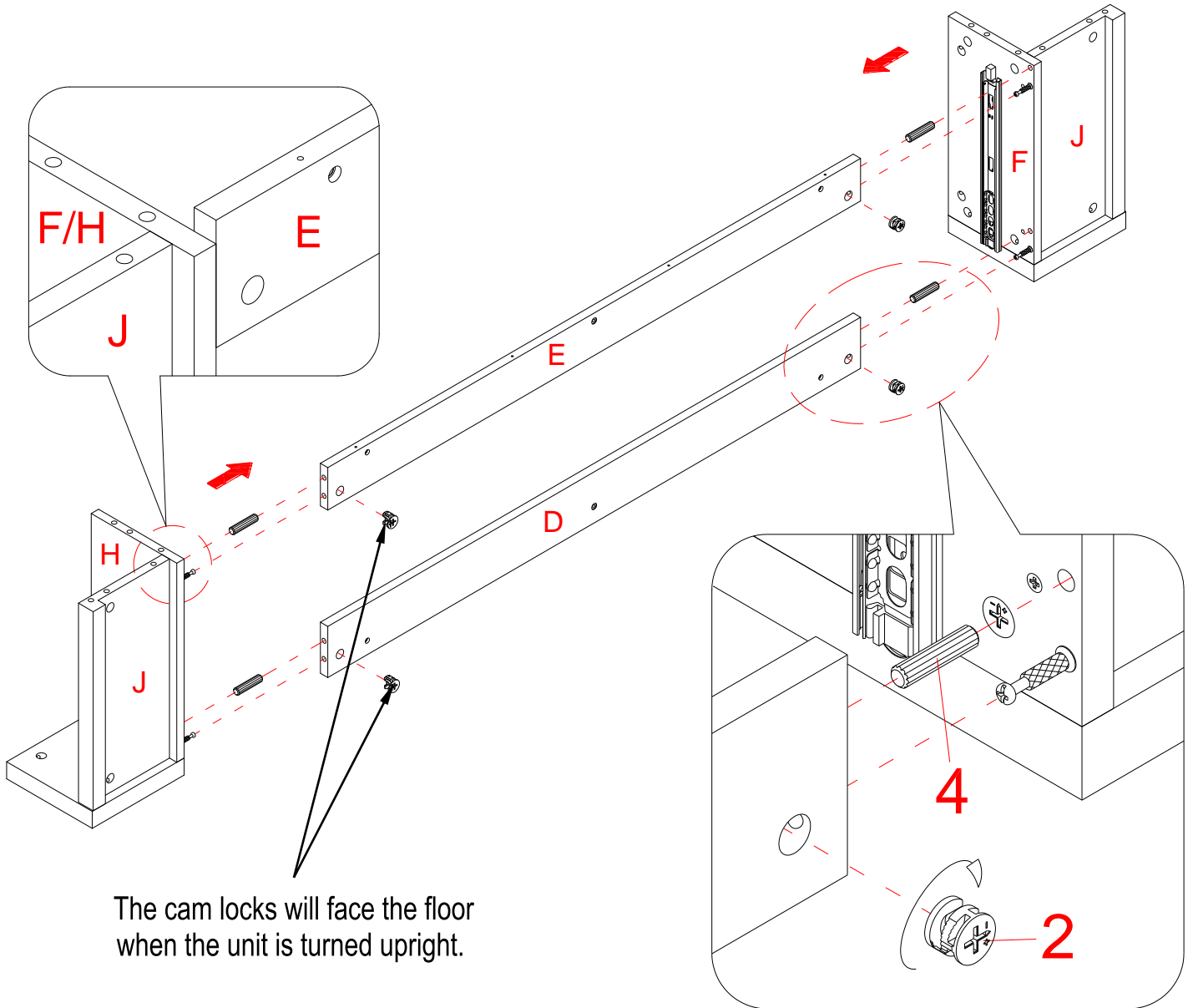

Large Cam Lock
(4 used in this step)



②

M8 x 30 mm Wood Dowel
(4 used in this step)

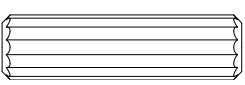

④

14. Attach the Front and Back Stretchers (D and E) between the Drawer Box Side Panels (F and H) with four Large Cam Locks (2) and four M8 x 30 mm Wood Dowels (4).

Assembly Instructions

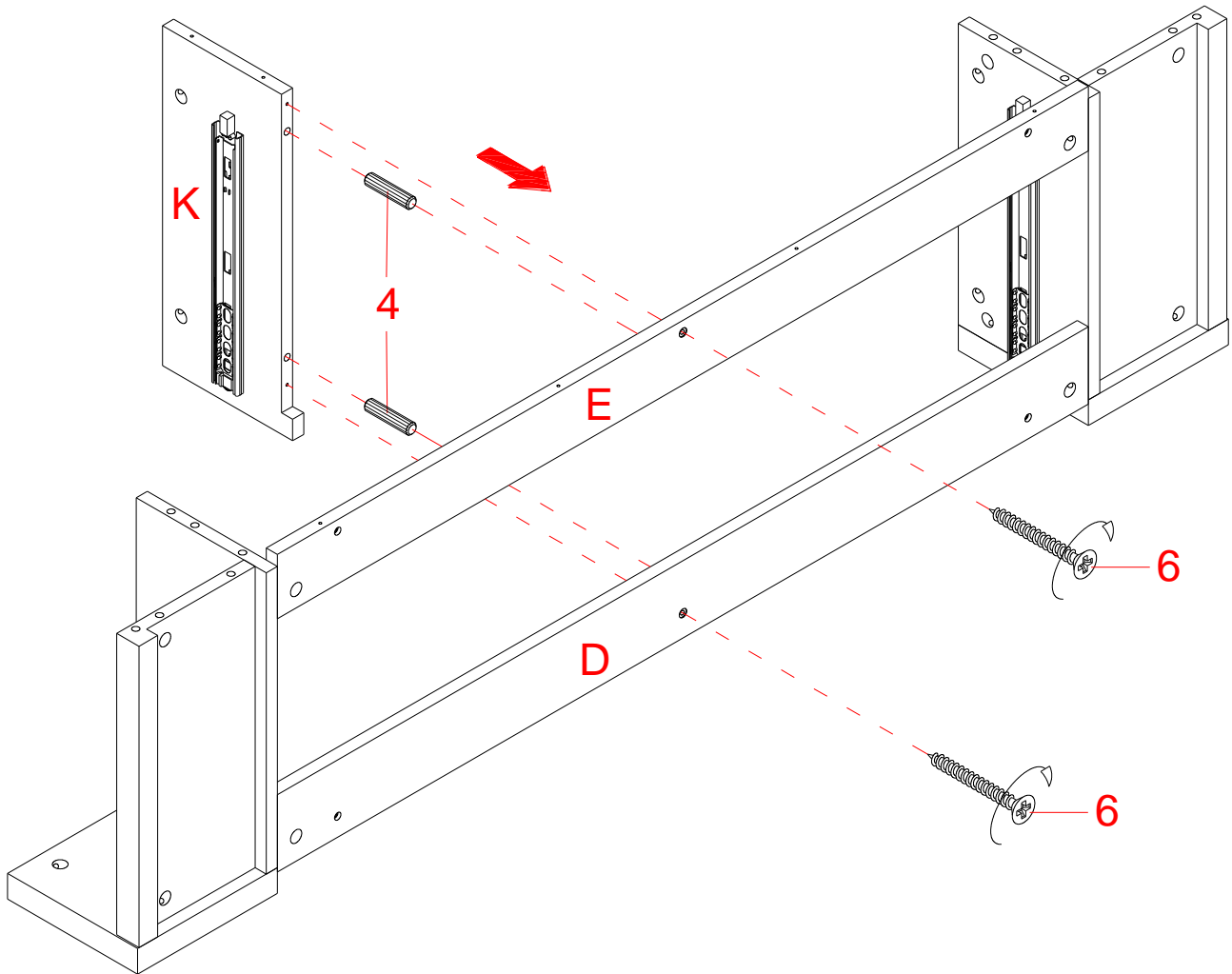

M8 x 30 mm Wood Dowel
(2 used in this step)

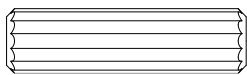

④

M4 x 32 mm Screw
(2 used in this step)



⑥

15. Attach the Partition Panel (K) to the Front and Back Stretchers (D and E) with two M8 x 30 mm Wood Dowels (4) and two 32 mm Screws (6).

Assembly Instructions

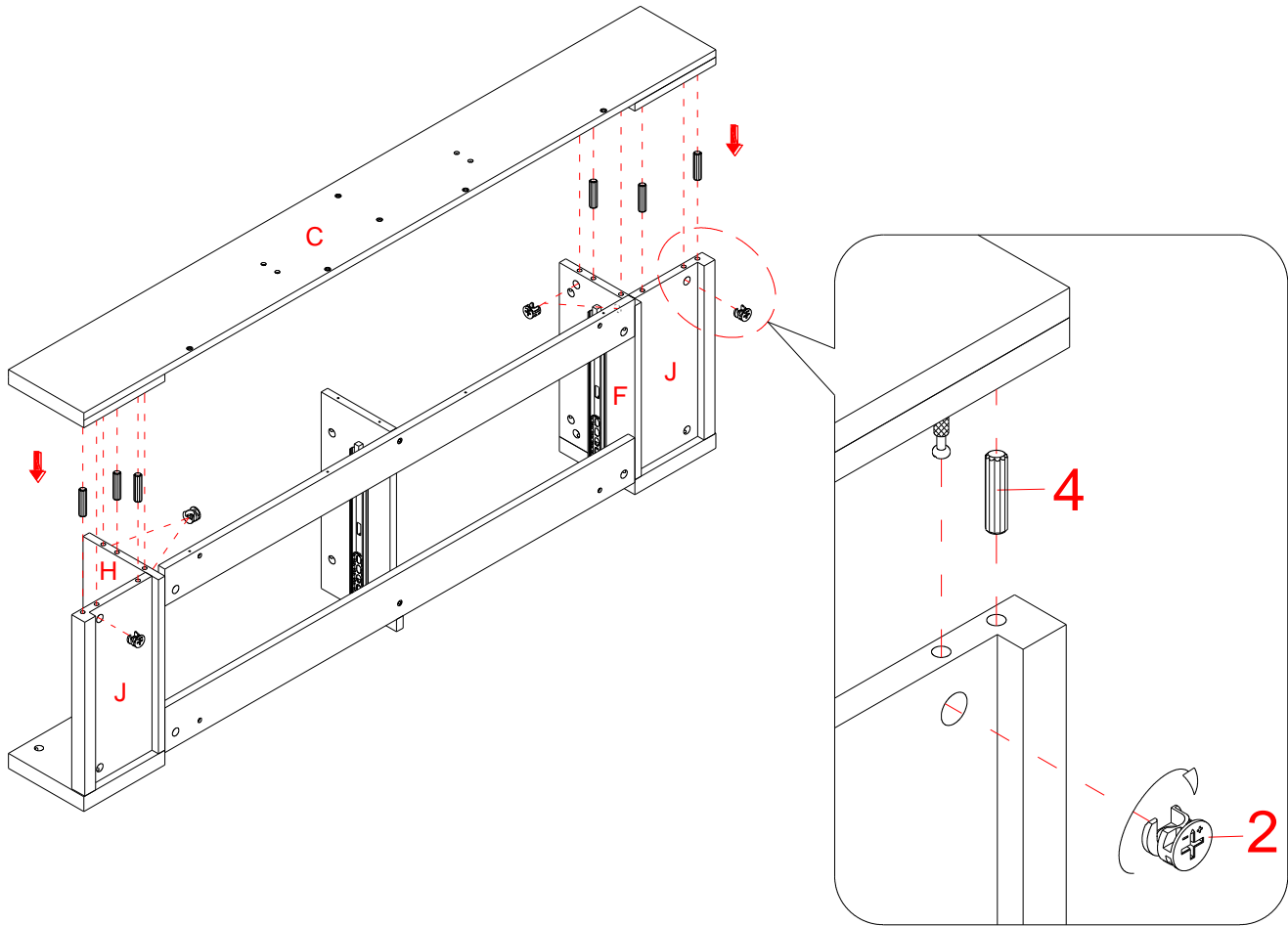

Large Cam Lock
(6 used in this step)



②

M8 x 30 mm Wood Dowel
(6 used in this step)

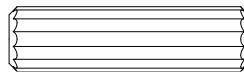

④

16. Attach the Drawer Box Back Panel (C) to the Drawer Box Side Panels (F and H) and the Fixed Shelves (J) with six Large Cam Locks (2) and six M8 x 30 mm Wood Dowels (4).

Drawer Assembling

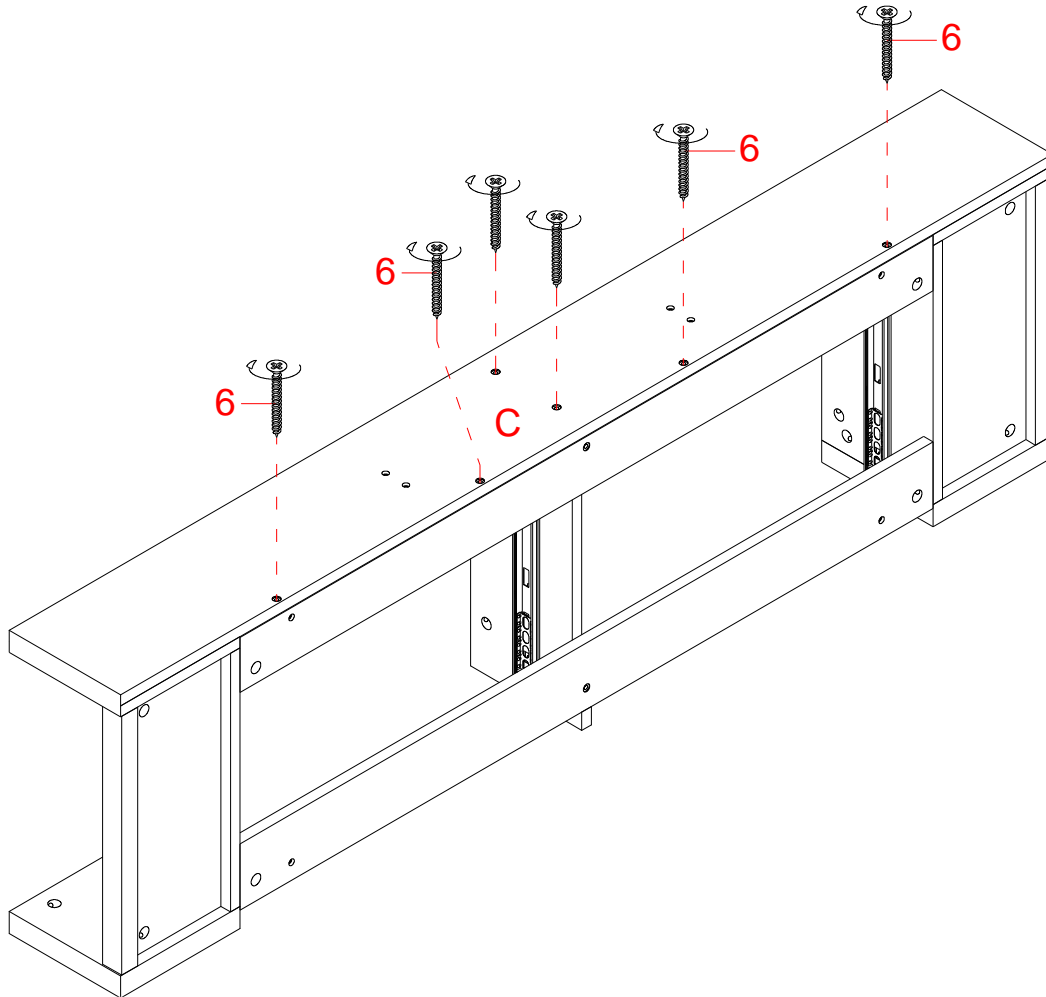

M4 x 32 mm Screw
(6 used in this step)

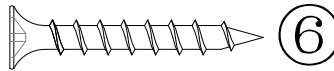

17. Fasten the Drawer Box Back Panel (C) to the Back Stretcher (E) and the Partition Panel (K) with six 32 mm Screws (6).

Assembly Instructions

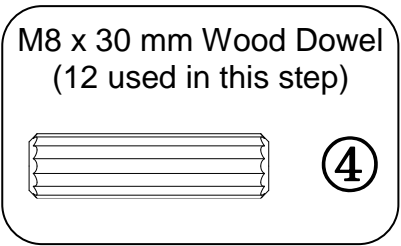
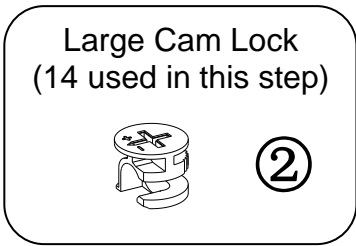
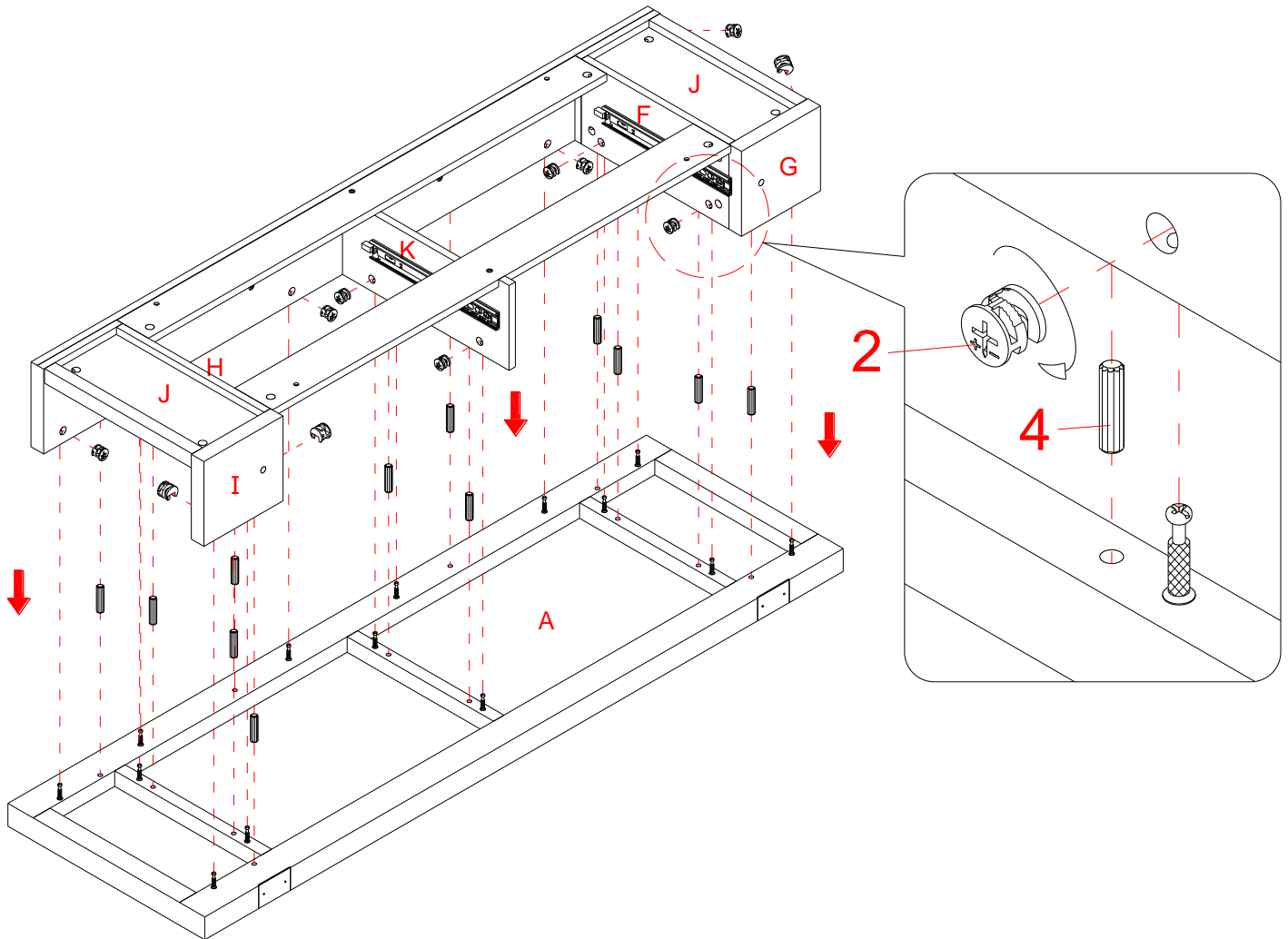

18. Position the Top Panel (A) upside down on a smooth and protected surface.

19. Align and attach the previous assembly to the Top Panel (A) with the M8 x 30 mm Wood Dowels (4) and the Large Cam Locks (2).

Assembly Instructions

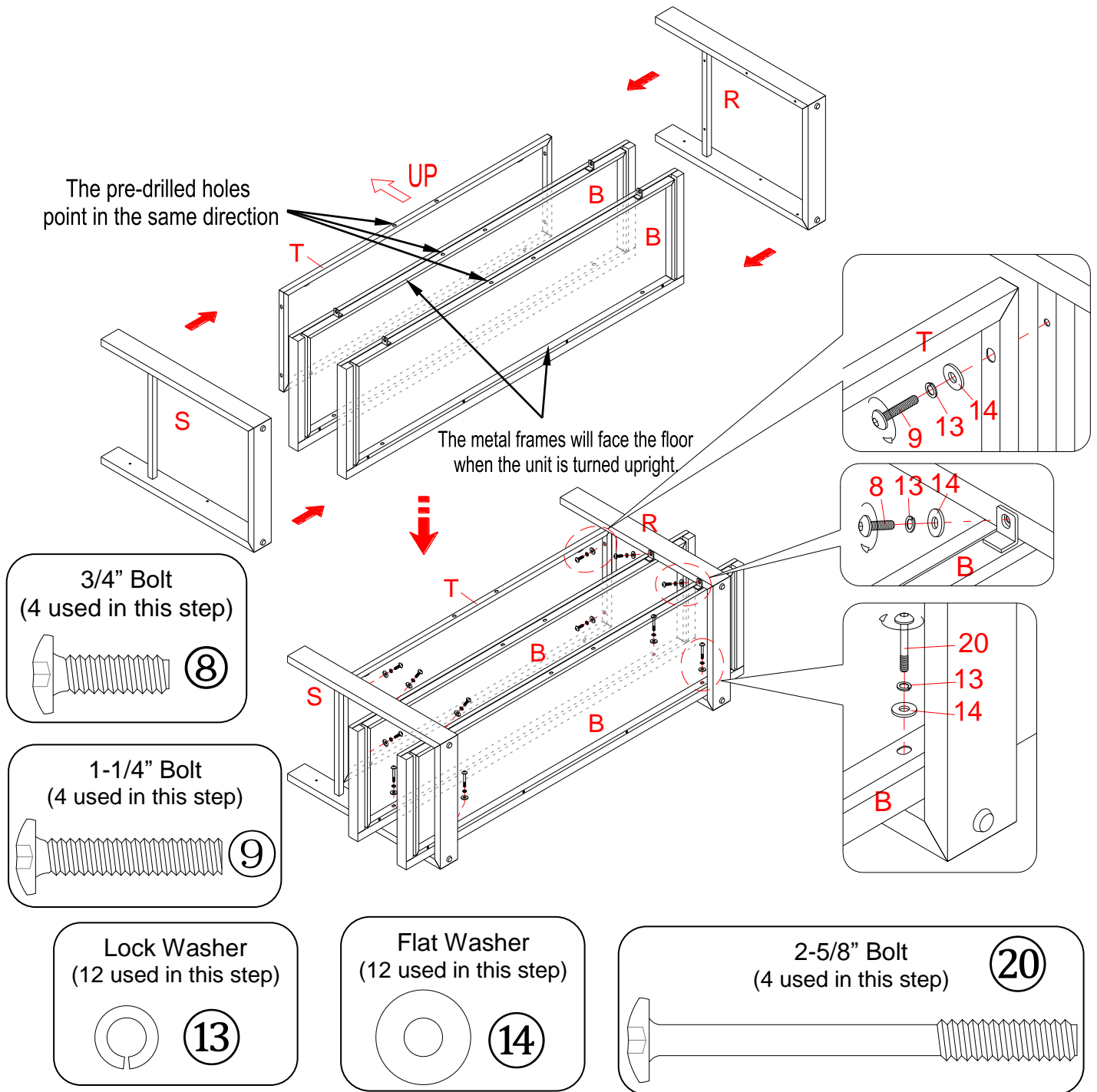

⚠ WARNING

DO NOT fully tighten the bolts initially until all the bolts are ready to assemble. To avoid causing damages to the thread, DO NOT over-tighten the bolts.

20. Fit two Lower Shelves (B) and the Top Metal Frame (T) between the Legs (R and S).
21. Attach the Top Metal Frame (T) to the top rails of Legs (R and S) with four 1-1/4" Bolts (9) and four Washers (13 and 14). Be sure the metal tabs will face up when the unit is turned upright.
22. Fasten the Lower Shelves (B) to the back posts of the Legs (R and S) with four 3/4" Bolts (8) and four Washers (13 and 14) and secure to the front posts with four 2-5/8" Bolts (20) and four Washers (13 and 14). **DO NOT** tighten the bolts.

Assembly Instructions

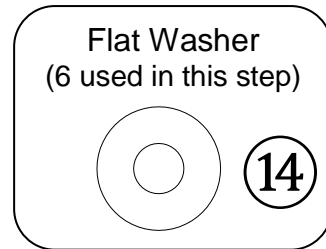
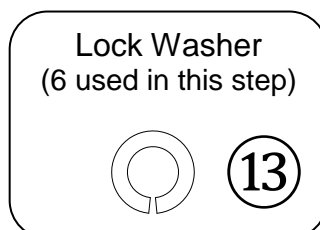
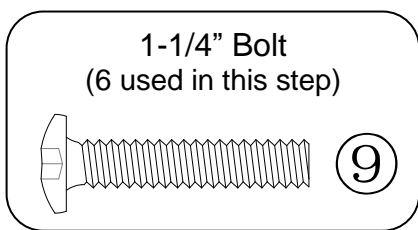
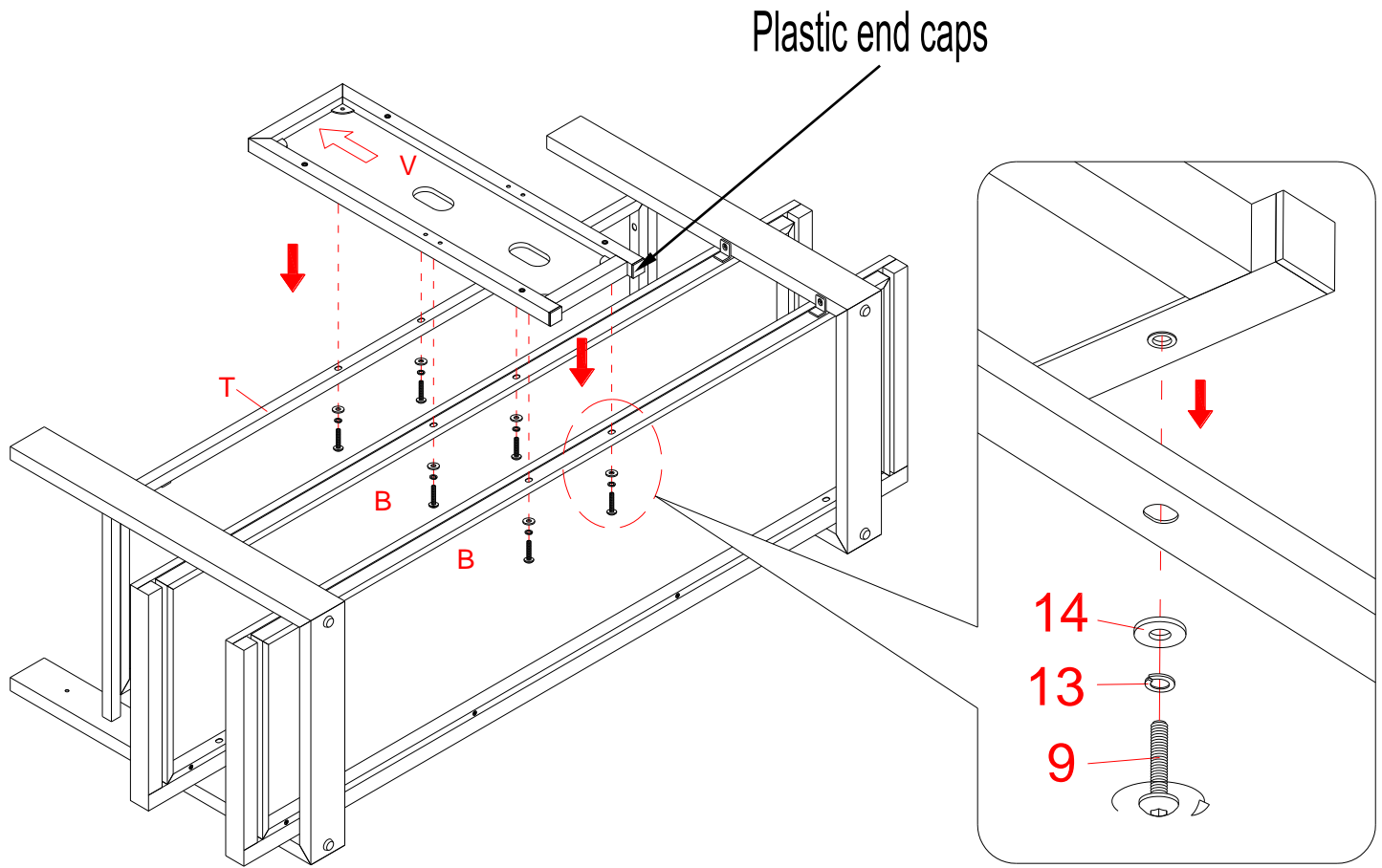

23. Align and attach the Back Frame (V) to the Metal Frames (B and T) starting with Middle Shelf (B), using six 1-1/4" Bolts (9) and six Washers (13 and 14).

Assembly Instructions

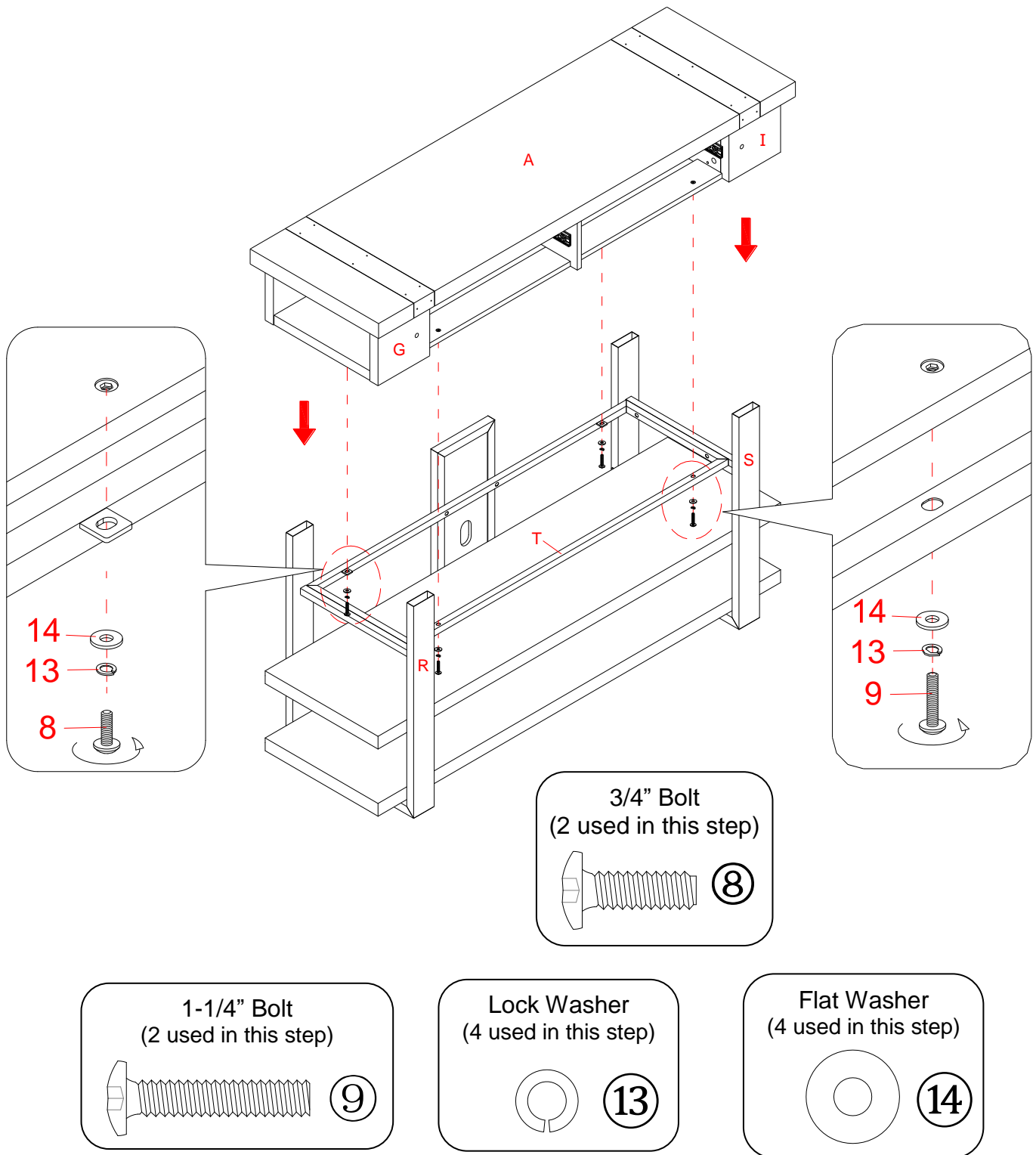

24. Turn the previous assembly upright.

25. Align and attach the assembled drawer box to the Top Metal Frame (T) with two 3/4" Bolts (8), two 1-1/4" Bolts (9) and four Washers (13 and 14).

Assembly Instructions

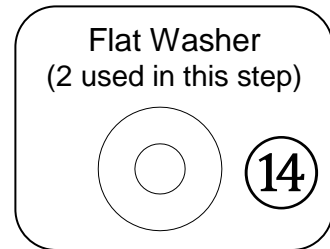
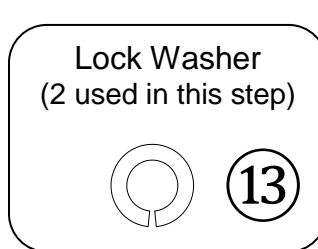
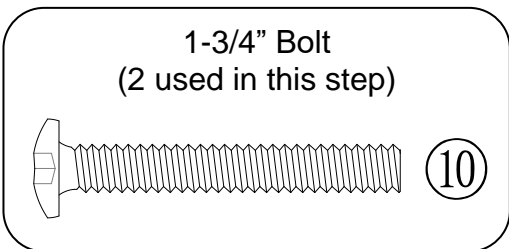
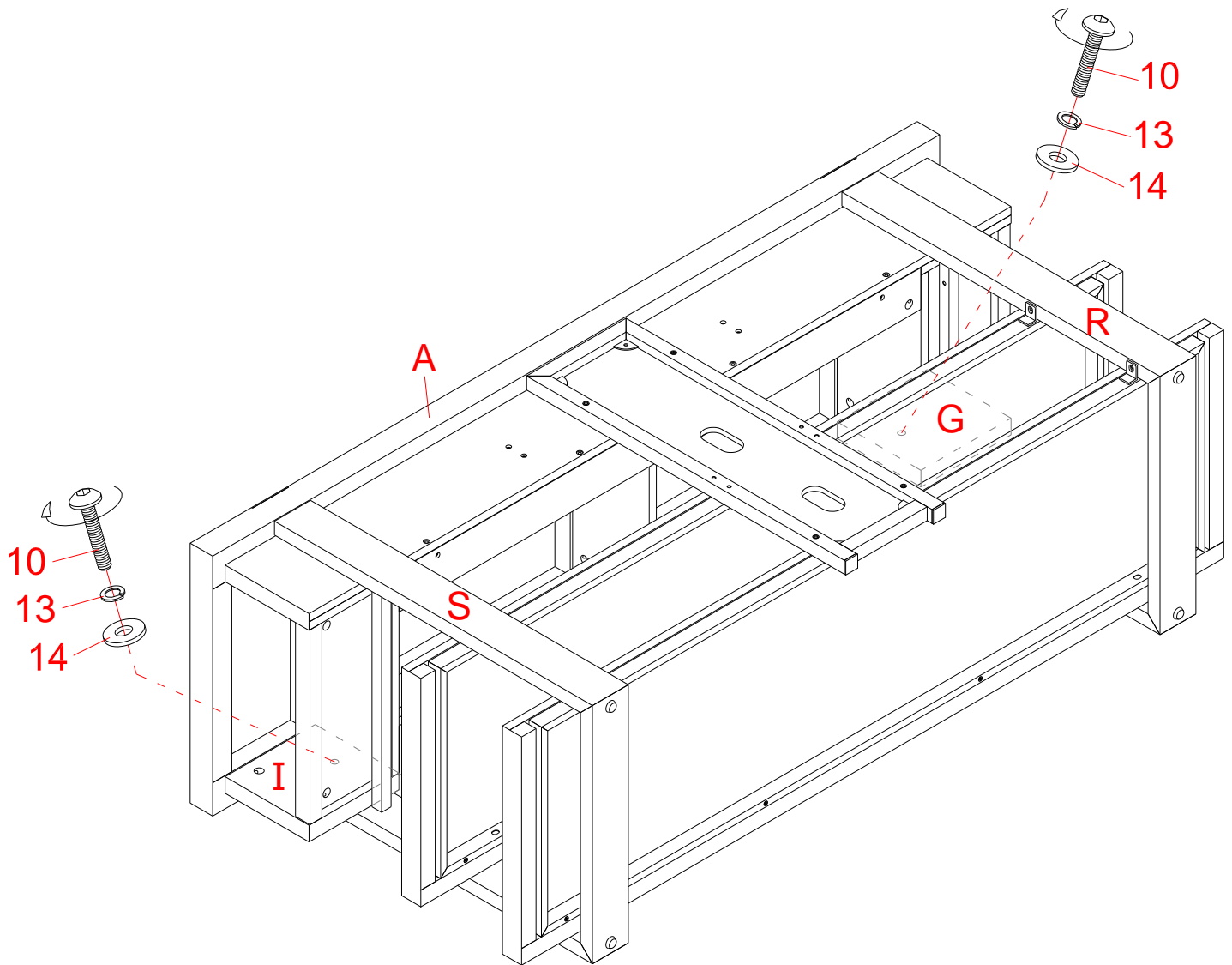

26. Lay the assembled unit at its front edge carefully. Fasten the Drawer Box Front Panels (G and I) to the Legs (R and S) with two 1-3/4" Bolts (10) and two Washers (13 and 14). Tighten all bolts with the provided 4 mm hex wrench.

Assembly Instructions

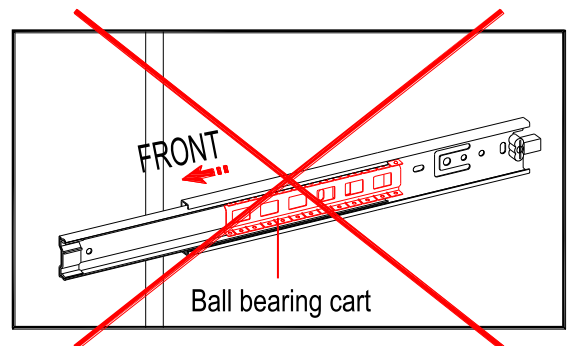
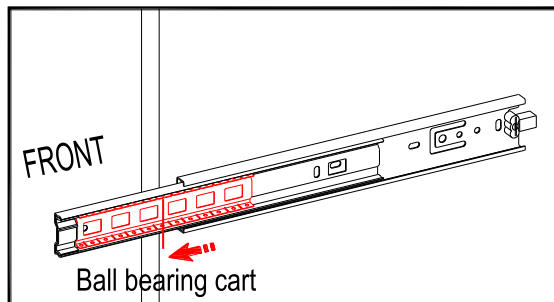
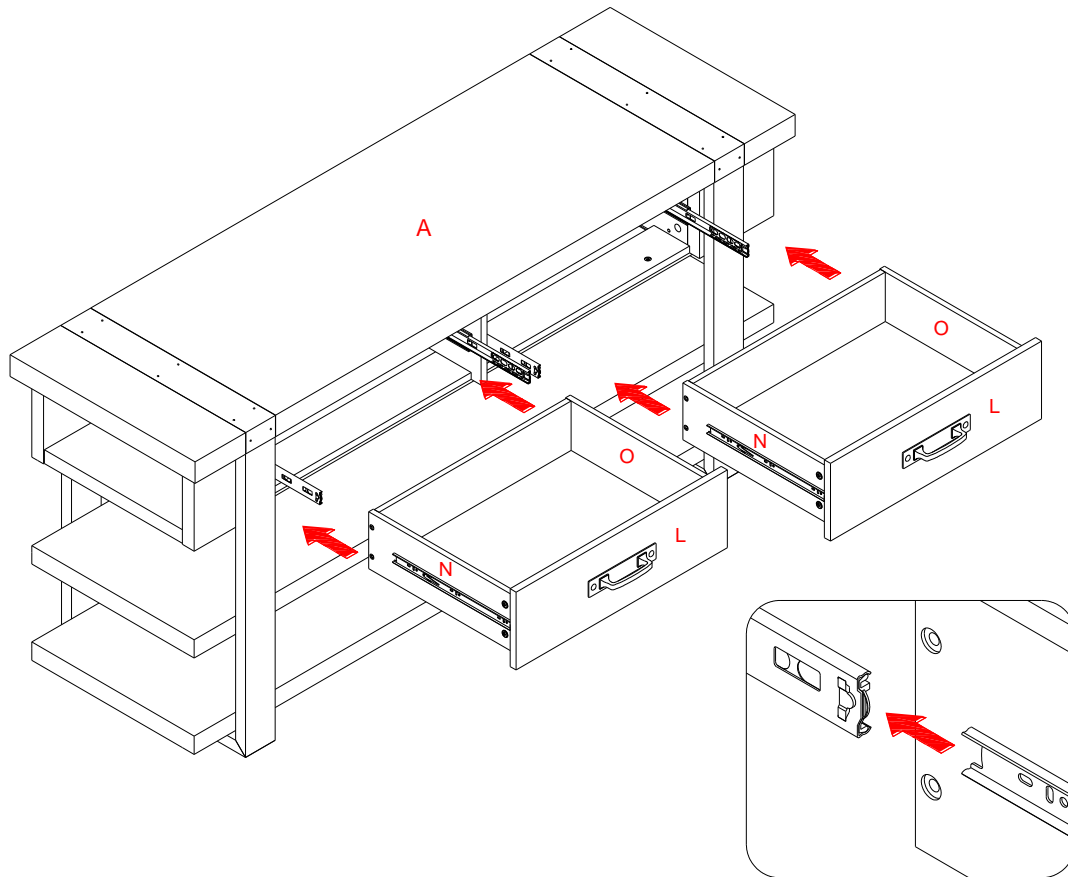

27. Turn the previous assembly upright and insert the assembled drawers into the frame. Extend the Ball Bearing Slide Tracks on the Panels all the way forward (including ball bearing cart). Then align the Slide Runners on the assembled drawers with the Slide Tracks and push the drawers carefully inside until it stops.

NOTE: If the drawer does not go in smoothly, please take it out and repeat the step. If you need to remove the drawer, please pull the drawer all the way out, then simultaneously push the plastic release lever of the ball bearing slides up on one side and down on the other side, and then pull it completely out.



If you choose table-top console configuration, continue to the next step.
If mounting TV with the floating swivel mount, skip ahead to PAGE 29.

Assembly Instructions for Table-top Stand

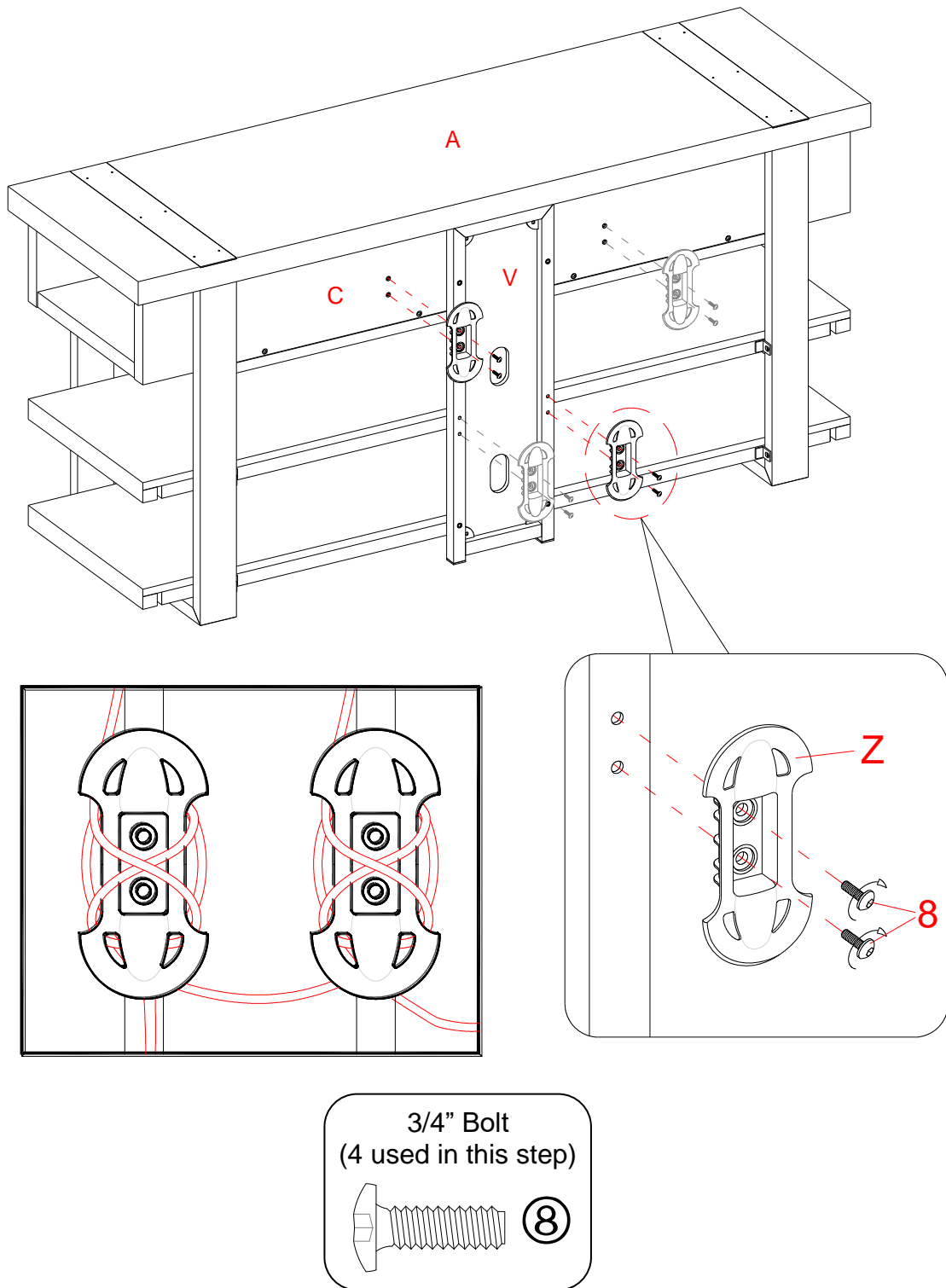

28. Attach 2 Cable Wheels (Z) to the backside of the Drawer Box Back Panel (C) or Back Frame (V) with four 3/4" Bolts (8). Tighten the bolts with the enclosed hex wrench.

NOTE: You can use the cable wheels to help keep your entertainment center's cables and cords organized.

Assembly Instructions for Table-top Stand

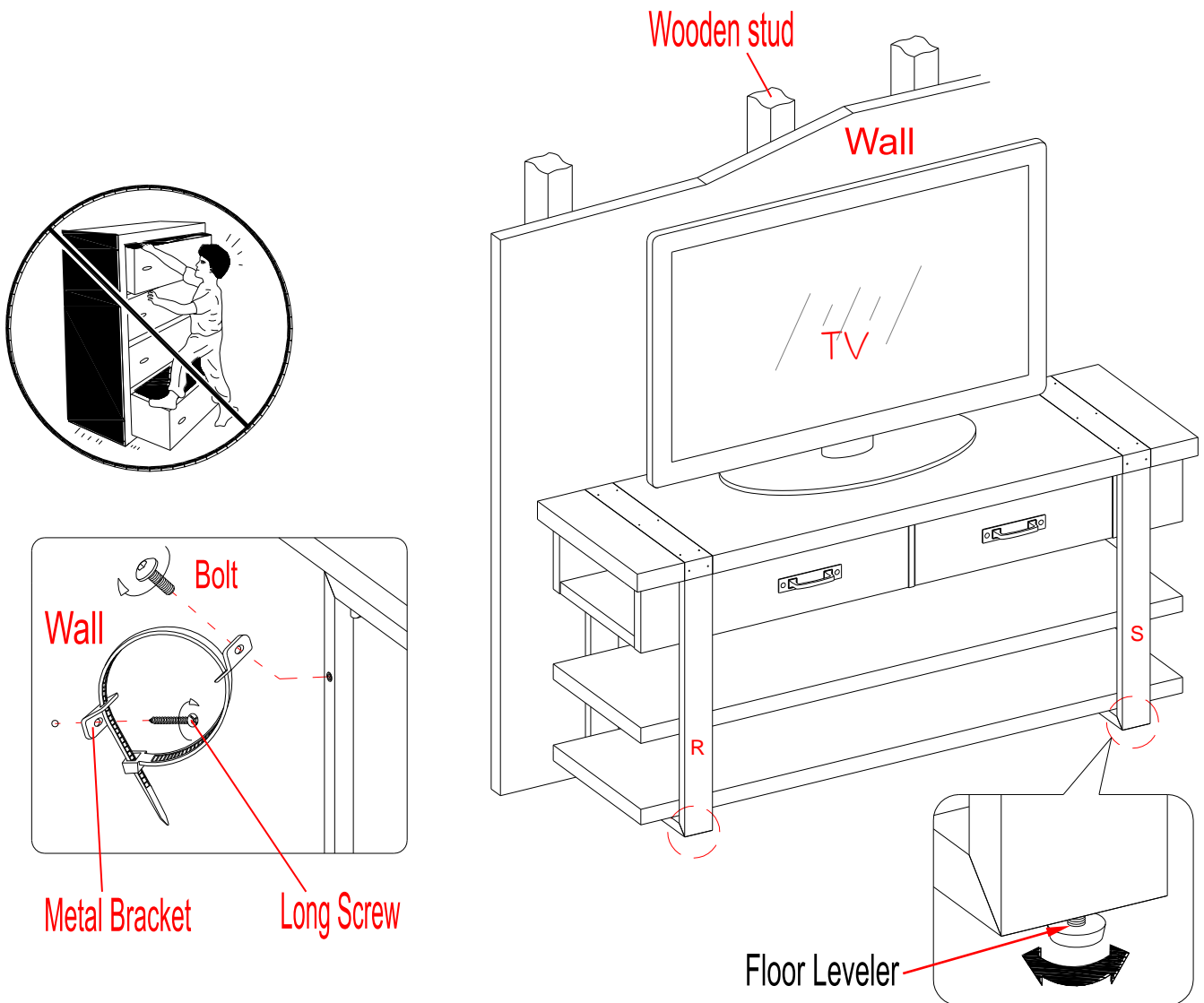

Tools required (not provided): Phillips screwdriver, stud finder, power drill and 3 mm/0.1 in drill bit.

29. Position the assembled stand at the desired location against a wall. If necessary, adjust the pre-attached Floor Levelers at the bottom of Legs (R and S) to level the unit. Now, follow the instructions printed on the plastic bag containing the Tipping Restraint Hardware to attach the tip-over restraint to the Back Frame and the wall.

NOTE: The tipping restraint hardware included is for wooden stud wall construction. It must be attached to a wall stud. Depending upon your wall construction, different anchor hardware maybe required. Please contact your local hardware store for assistance. Young children can be seriously injured by tipping furniture. You must install the Tipping Restraint Hardware with the unit to prevent the unit from tipping, causing any accidents or damage. The tipping restraints are intended only as a deterrent, they are not a substitute for proper adult supervision. The tipping restraints are not earthquake restraints. If you wish to add the extra security of earthquake restraints, they must be purchased and installed separately.

30. The stand is now ready for use. Be sure to position your Flat Panel TV in the center of the stand.

NOTE: If you choose the Tilting Wall Mount, proceed to PAGE 37.

Assembly Instructions for: Floating Swivel Mount

The threaded sockets for cable wheels face backward

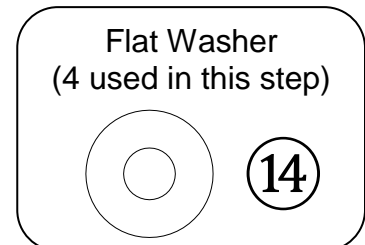
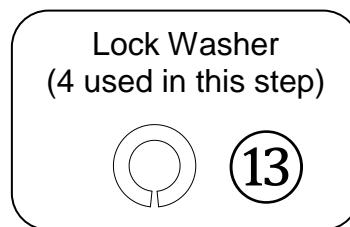
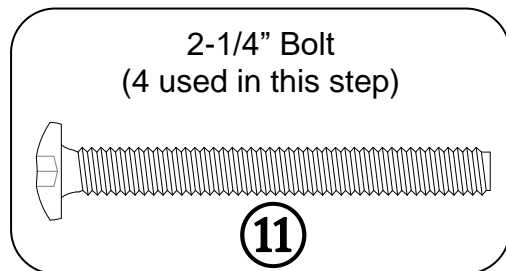
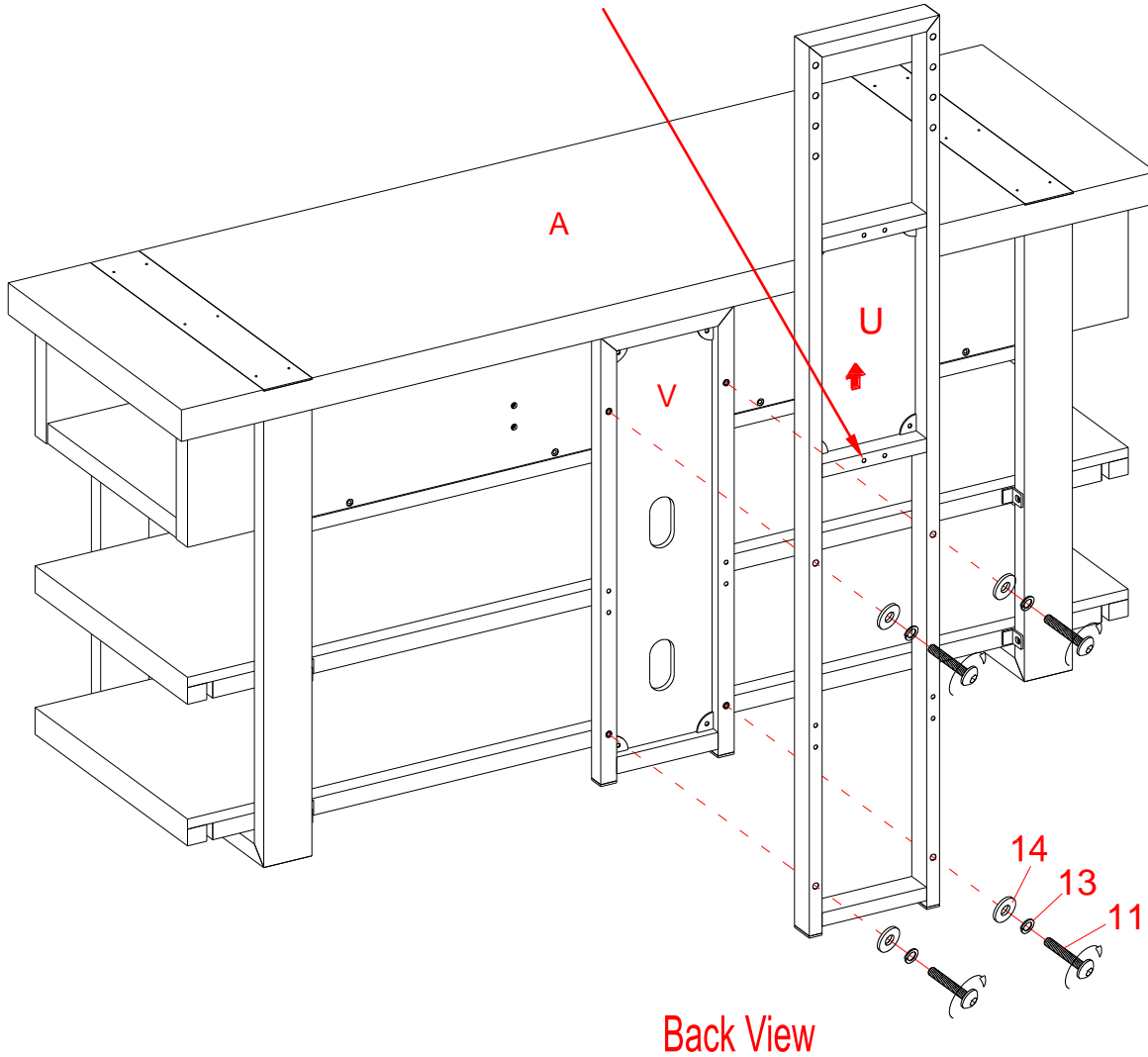

31. Attach the Floater Post (U) to the back of the Back Frame (V) with four 2-1/4" Bolts (11) and four Washers (13 and 14). Tighten all bolts with the provided 4 mm hex wrench

Assembly Instructions for Floating Swivel Mount

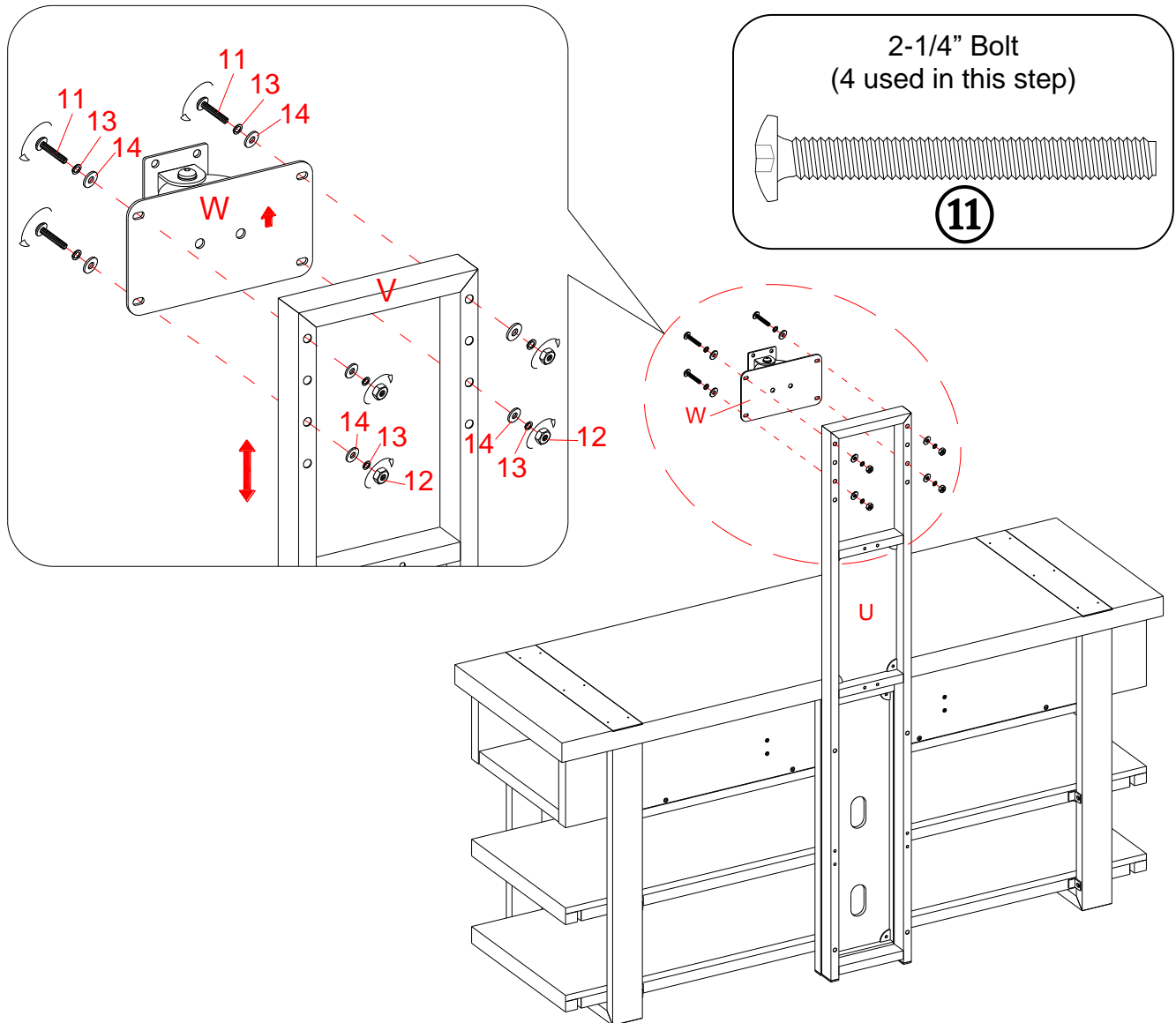

Hex Nut
(4 used in this step)

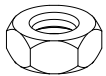

12

Lock Washer
(8 used in this step)



13

Flat Washer
(8 used in this step)

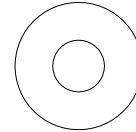

14

32. Attach the Swiveling Bracket (W) to the top of Floater Post (U) with the pivoting bolt head up. Securely tighten with the provided open wrench and 4 mm hex wrench.

NOTE: The Floater Post can provide two height options for your TV set. Refer to your TV size and adjust the Swiveling Bracket at your desired height to offer optimum viewing.

Assembly Instructions for Floating Swivel Mount

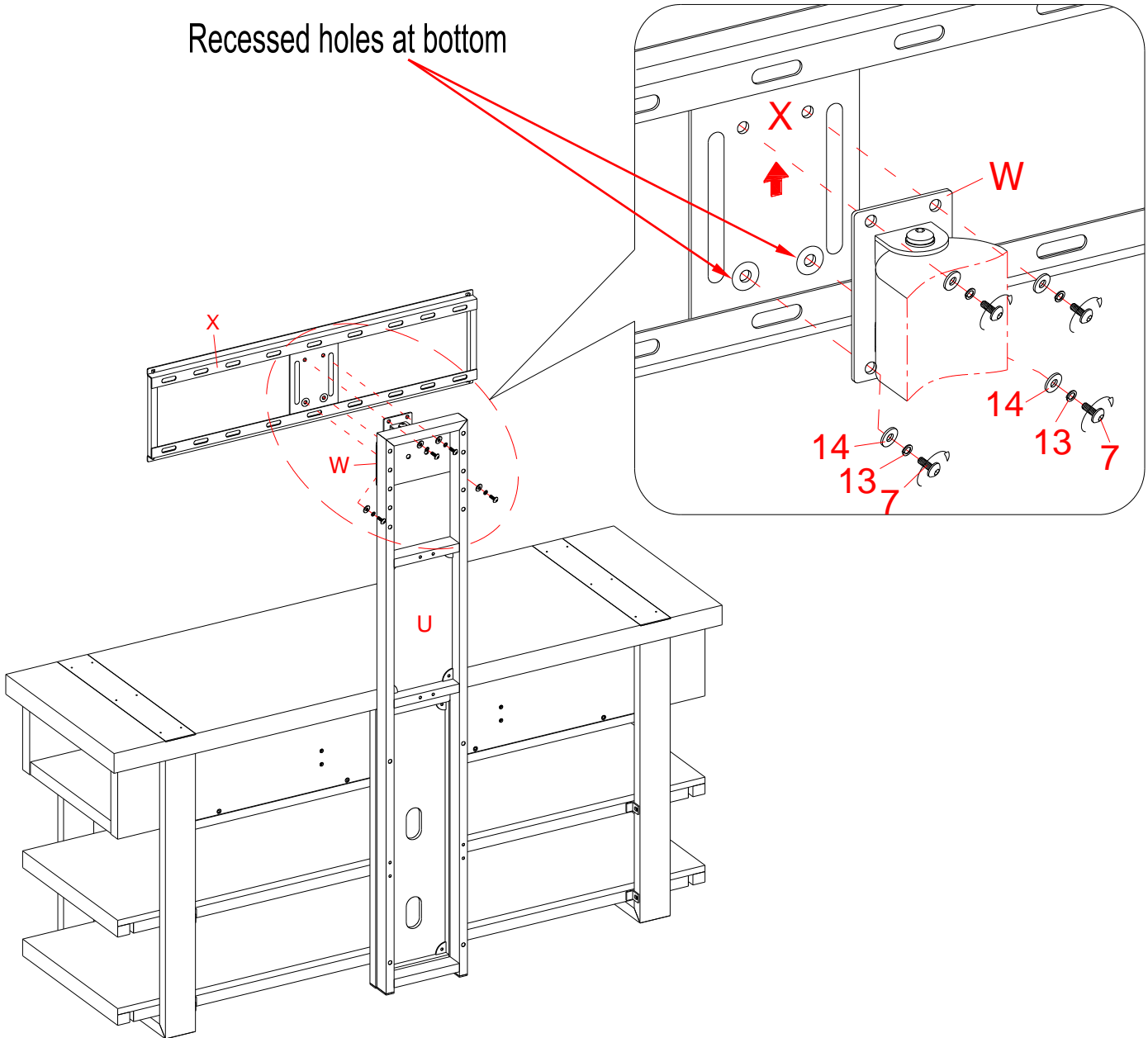

1/2" Bolt
(4 used in this step)

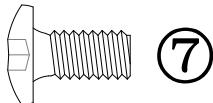

Lock Washer
(4 used in this step)



Flat Washer
(4 used in this step)

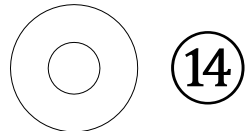

33. Hold and attach the flat side of the Mounting Frame (X) to the Swiveling Bracket (W) using four 1/2" Bolts (7) and four Washers (13 and 14). Make sure the recess holes on the Mounting Frame are at the bottom. Tighten all bolts with the provided 4 mm hex wrench

Mounting the Monitor Brackets to a television with a Flat Back

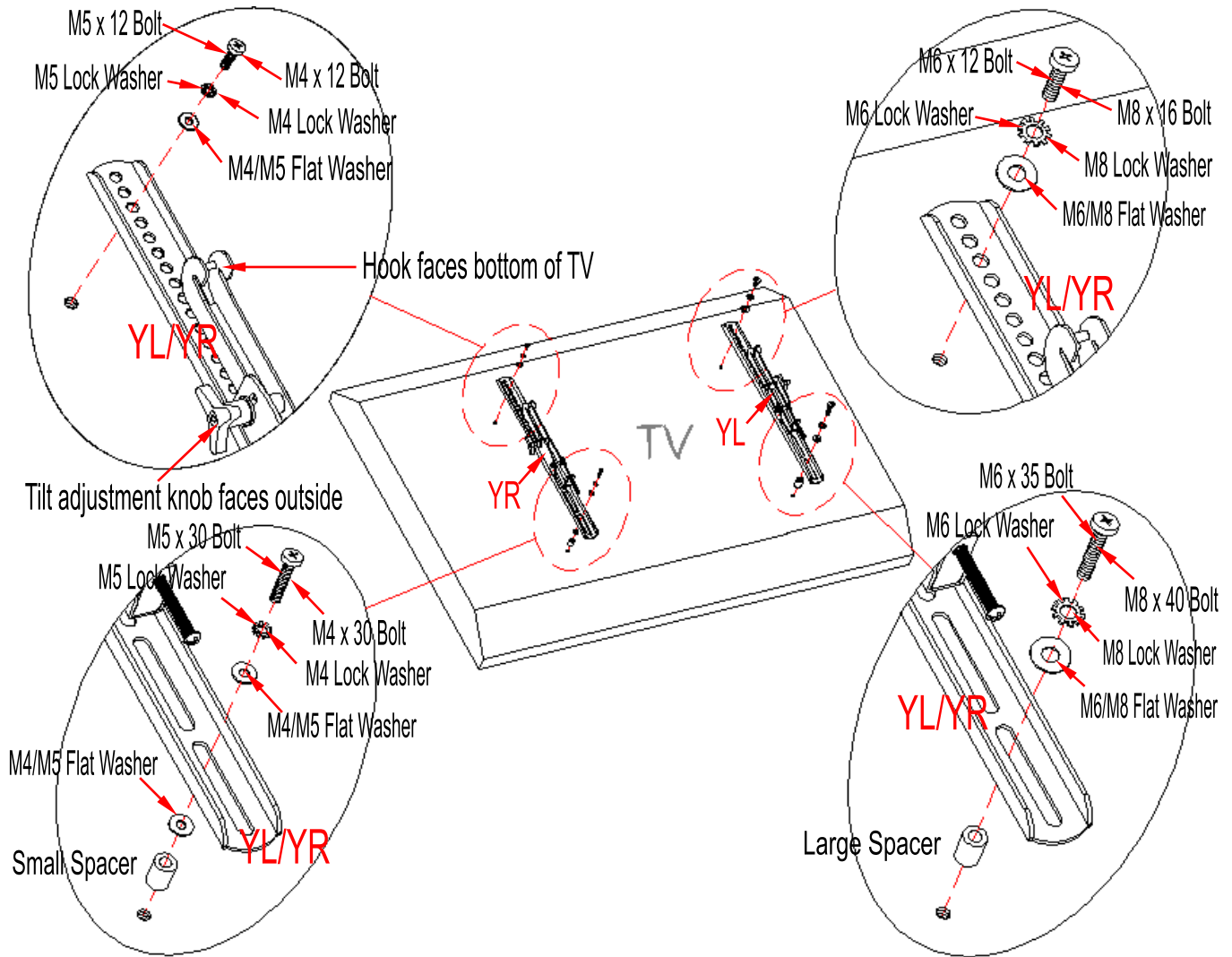

NOTE: For televisions with a curved or recessed back, proceed directly to next page.

34. Determine the correct diameter of the bolt the TV requires by hand threading them into the threaded insert on the back of the TV. If you encounter any resistance, stop immediately. If you are unable to find the correct bolt, consult a local hardware store.
35. Follow the appropriate diagram above to attach the Monitor Brackets (YL/YR) to the back of the TV with the selected fasteners. Make sure the Monitor Brackets are centered and level with each other. Secure the bolts with a Phillips screwdriver. DO NOT over tighten the bolts.

NOTE: Lean the TV up against a wall, or other solid surface, when attaching the Monitor Brackets. DO NOT place the TV face down on the glass as this may cause permanent damage.

NOTE: If mounting your TV in the Wall Mount configuration, once you have completed the installation of the monitor brackets, proceed to PAGE 37.

Mounting the Monitor Brackets to a television with a Curved/Recess Back

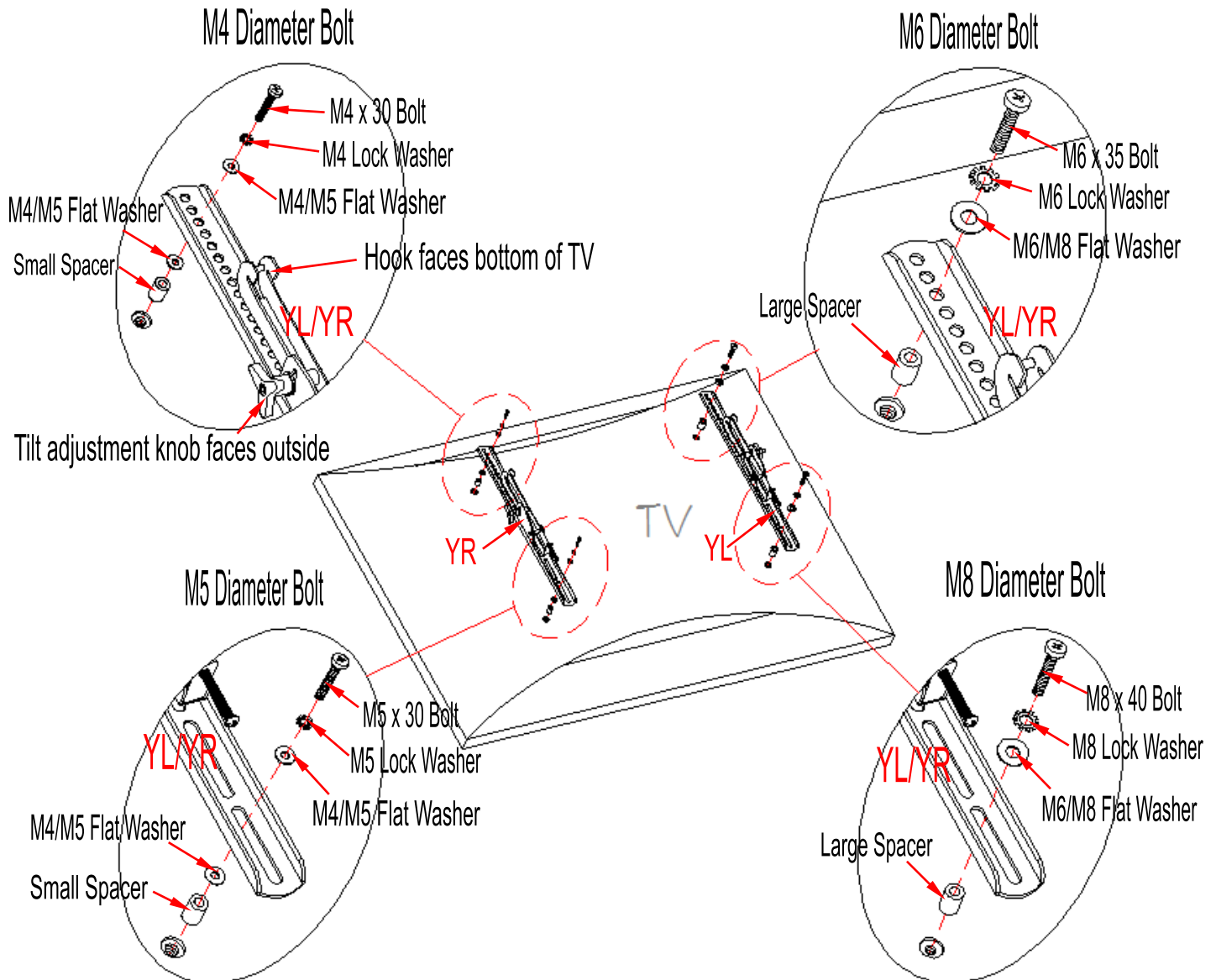

36. Determine the correct diameter of the bolt the TV requires by hand threading them into the threaded insert on the back of the TV. If you encounter any resistance, stop immediately. If you are unable to find the correct bolt consult a local hardware store.

37. Follow the appropriate diagram above to attach the Monitor Brackets (YL/YR) to the back of the TV with the selected fasteners. Make sure the Monitor Brackets are vertically centered and level with each other. Secure the bolts with a Phillips screwdriver. DO NOT over tighten the bolts.

NOTE: Lean the TV up against a wall, or other solid surface, when attaching the Monitor Brackets. DO NOT place the TV face down on the glass as this may cause permanent damage.

NOTE: If mounting your TV in the Wall Mount configuration, once you have completed the installation of the monitor brackets, proceed to PAGE 37.

Assembly Instructions for Floating Swivel Mount

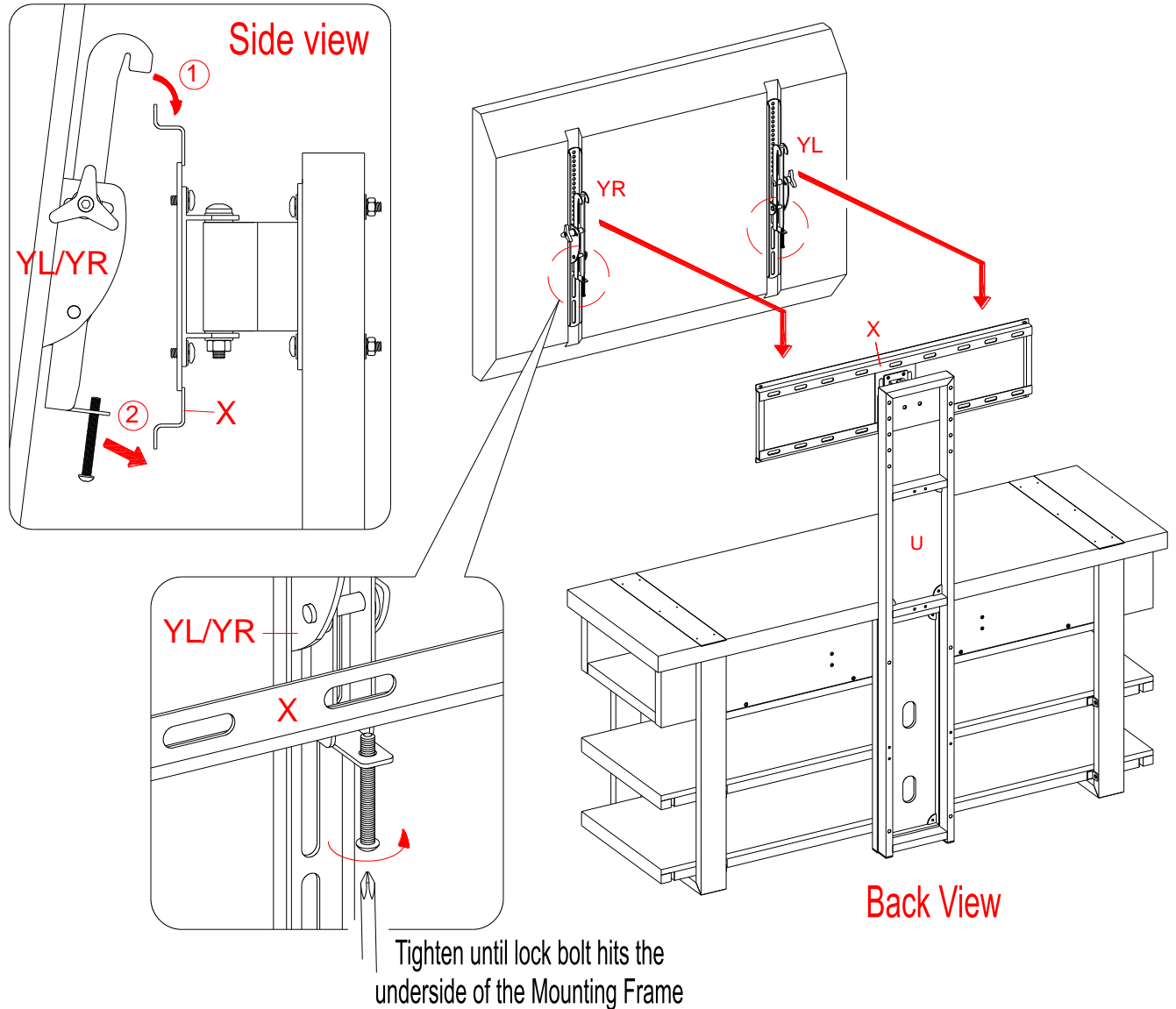

MAKE SURE ALL BOLTS ARE TIGHT AND THE SPINE IS AT A 90 DEGREE ANGLE. USE A QUALITY LEVEL TO VERIFY THE MOUNTING FRAME IS LEVEL PRIOR TO INSTALLATION OF TV.

38. Ask for assistance to lift the television up to hang the Monitor Brackets (YL/YR) onto the Mounting Frame (X). Set the hooks on the Monitor Brackets (YL/YR) over the Mounting Frame (X) and then lower them onto the bars of the Mounting Frame.

NOTE: Loosen the Lock Bolt that is pre-attached to each Monitor Bracket to ensure an easy fit at the bottom hook.

39. Center the television and tighten both Lock Bolts with a long Phillips screwdriver until they hit the underside of the Mounting Frame (X) to secure it in place.

Assembly Instructions for Floating Swivel Mount

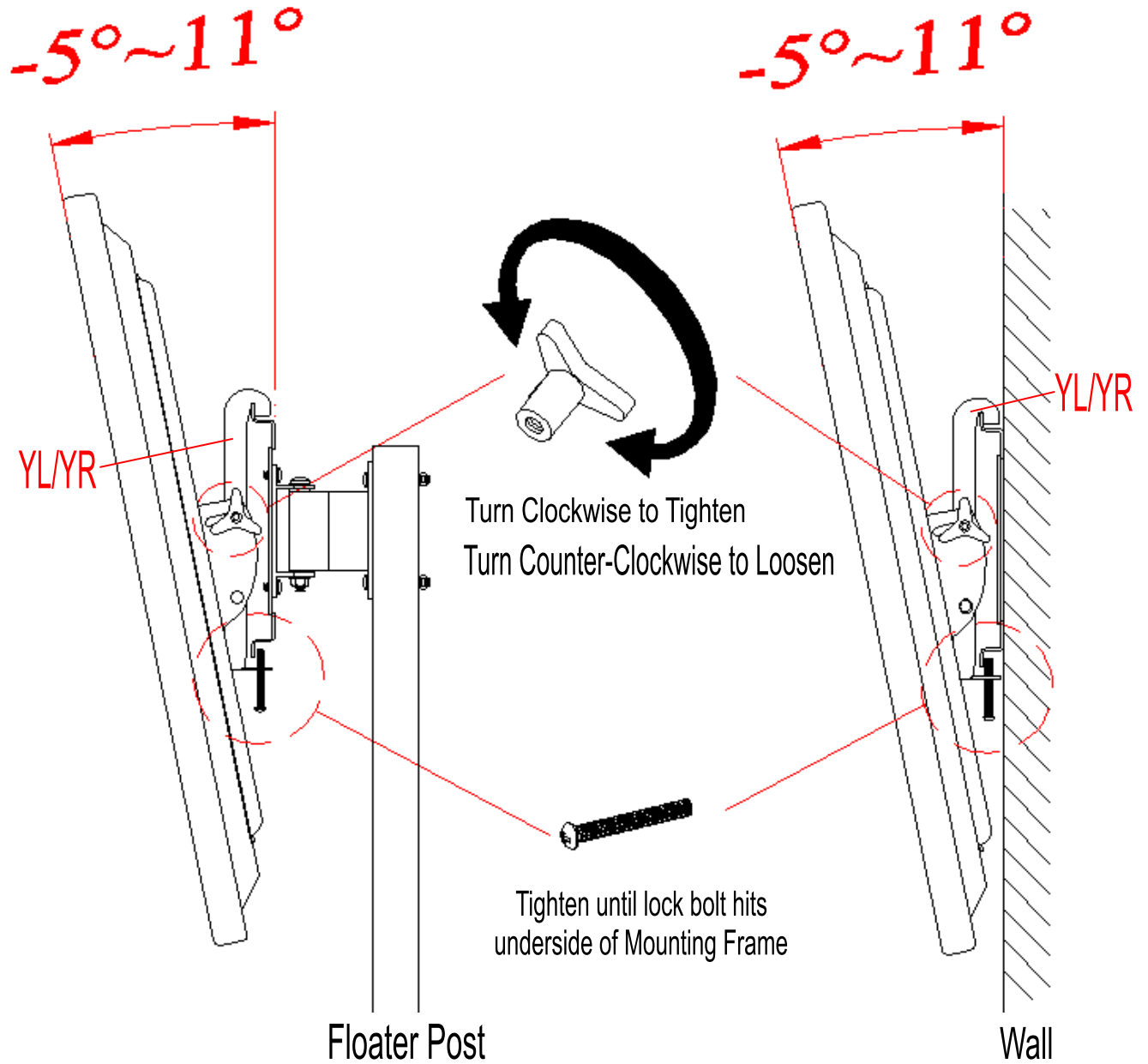

40. The Monitor Brackets (YL/YR) can tilt up to 11° downward and 5° upward, depending on your optimum viewing position. Keep the enclosed $3/16$ " Hex Wrench to ensure the Tilt Adjustment Knobs remain tightly fastened.

Assembly Instructions for Floating Swivel Mount

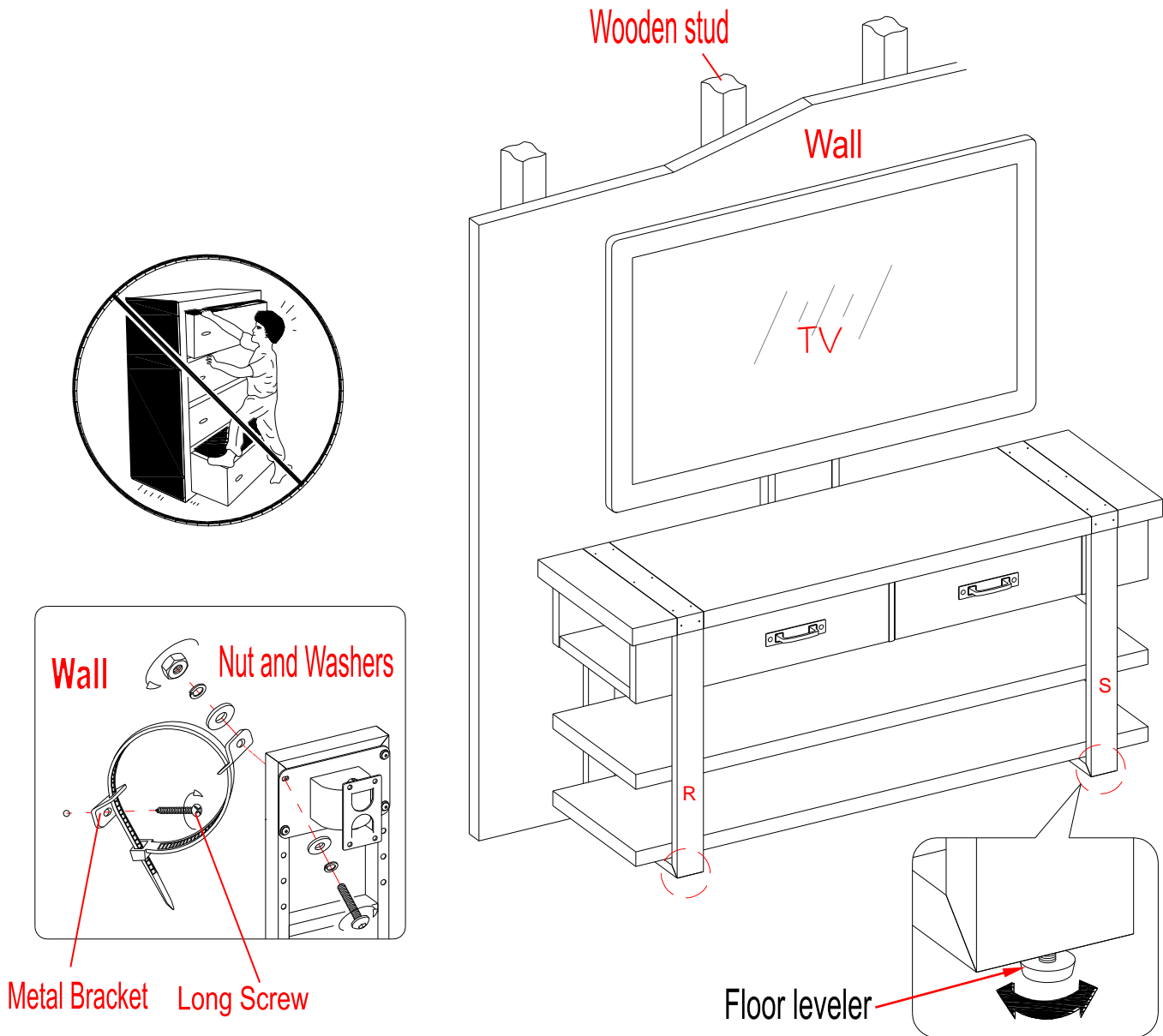

41. Attach two Cable Wheels (Z) to the back side of Floater Post (U) with four 3/4" Bolts (8).

42. Carefully move the stand and position it at the desired location against a wall. If necessary, adjust the pre-attached Floor Levelers at the bottom of Legs (R and S) to level the unit. Now, follow the instructions printed on the plastic bag containing Tipping Restraint Hardware Kit to attach the tip-over restraint to the Floater Post and the wall.

NOTE: The tipping restraint hardware included is for wooden stud wall construction. It must be attached to a wall stud. Depending upon your wall construction, different anchor hardware may be required. Please contact your local hardware store for assistance. Young children can be seriously injured by tipping furniture. You must install the Tipping Restraint Hardware with the unit to prevent the unit from tipping, causing any accidents or damage. The tipping restraints are intended only as a deterrent, they are not a substitute for proper adult supervision. The tipping restraints are not earthquake restraints. If you wish to add the extra security of earthquake restraints, they must be purchased and installed separately.

43. The stand is now ready for use. Swivel the TV left-or-right for optimum viewing control.



The following steps are only for those who wish to mount their TV directly to the wall. If you have already mounted your TV to the Swinging Floater or plan to display your TV on the top surface of the Stand, disregard the following steps.

Assembly Instructions for Universal Wall Mount Installing the Mounting Frame onto a WOODEN STUD WALL

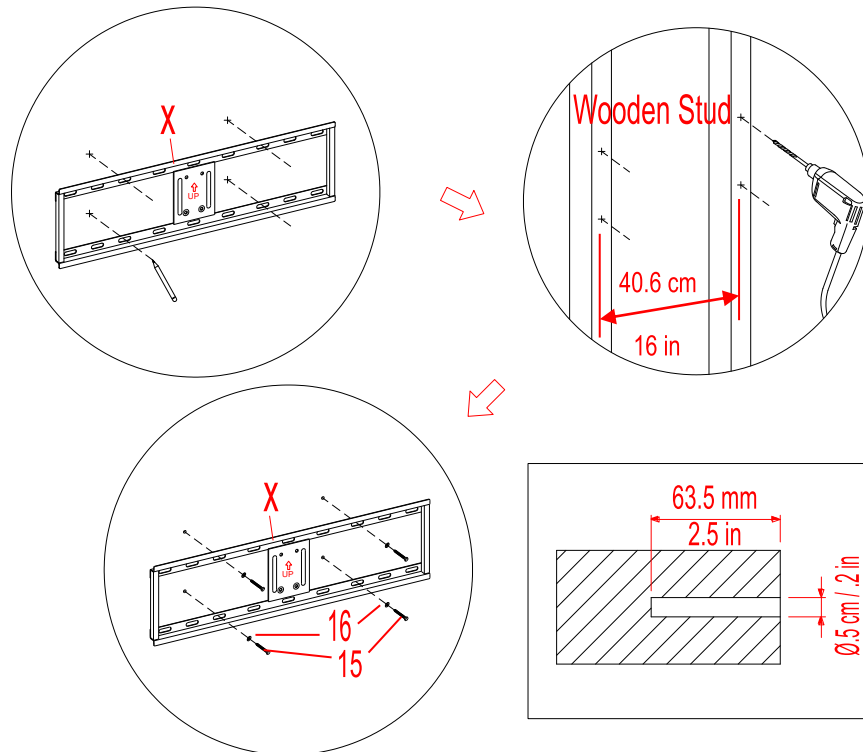

NOTE: If you are mounting your TV onto brick, solid concrete or concrete block walls, skip this section. This assembly requires an electric drill, level and stud finder (not included).

44. Using a stud finder, locate the edges of the wood studs. Find the center line of each stud and draw a vertical reference line on the wall over each one. Place the Mounting Frame (X) level against the wall where you intend to mount the TV. Using the Mounting Frame (X) as a template, mark 4 drill points (2 on top, 2 on bottom) with a pencil on the vertical reference lines you just drew.
45. With an electric drill (not included), drill 3/16 inch diameter holes to at least 2½ inch deep on the 4 drill points. While holding the Bracket Plate in place, loosely screw in the Lag Bolts (15).
46. Secure the Mounting Frame (X) to wall with Lag Bolts (15) and the Large Flat Washers (16) at the drill points. Tighten the bolts firmly, but be careful not to over-tighten.

⚠ WARNING Do not over-tighten the Lag Bolts. Tighten the Lag Bolts only until the Lag Bolt Washer is pulled firmly against the metal plate of the Mounting Frame. If there is a layer of drywall or other material, this drywall or other material may not exceed 5/8 inch in thickness. Failure to heed this caution may result property damage and/or personal injury.

Assembly Instruction for installing the Mounting Frame onto BRICK, SOLID CONCRETE OR CONCRETE BLOCK WALLS

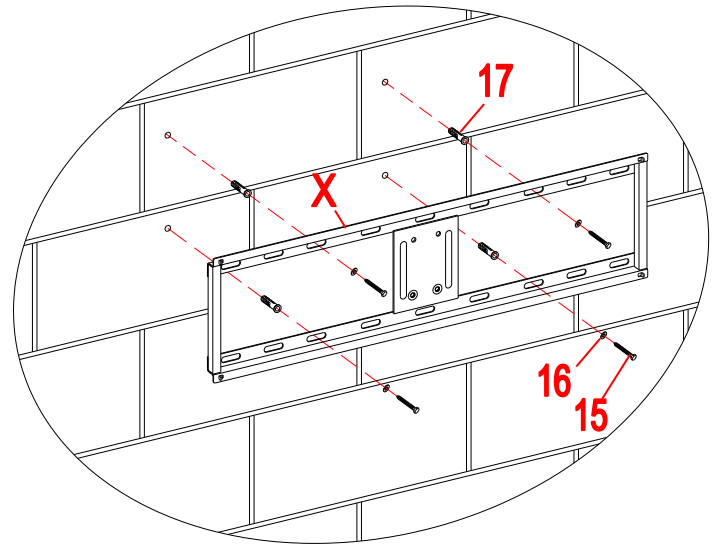
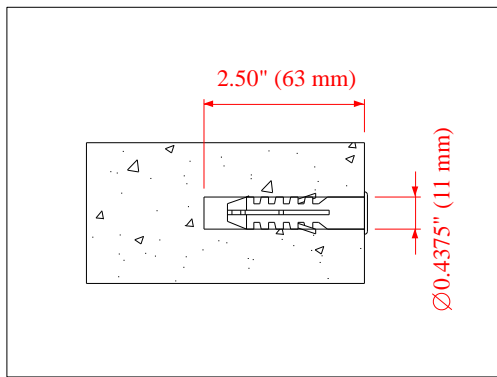
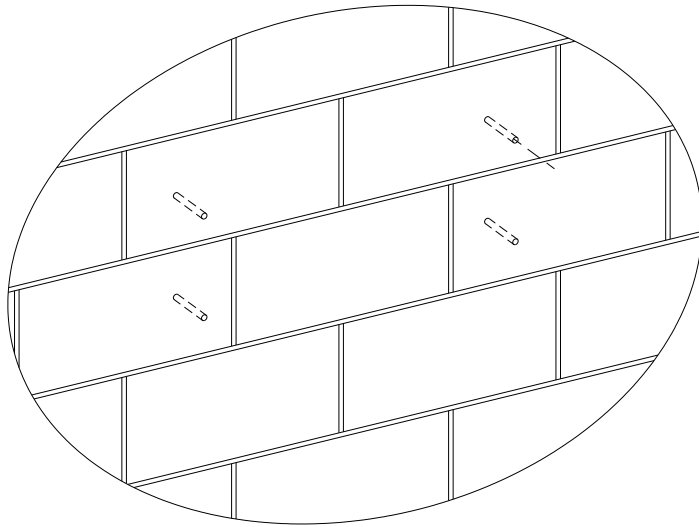

⚠ WARNING Maximum weight 135 lb. (61.3 kg)

⚠ WARNING Concrete Anchors should only be used for masonry mounting. NEVER use the wall anchors to mount the unit to drywall.

NOTE: If you are mounting your TV to a wall with wooden studs, skip this section. This assembly requires an electric drill and level (not included).

47. Begin by placing the Mounting Frame (X) level against the wall where you intend to mount the TV. Using the Mounting Frame (X) as a template, mark 4 drill points with a pencil.
48. With an electric drill (not included) on its low setting, drill 7/16 inch diameter holes to at least 2½ inch deep. Insert the Concrete Anchors (17) into the pre-drilled holes so that they are flush with the wall.
49. Place the Mounting Frame (X) level in the desired position against the wall. Secure the Mounting Frame (X) to the wall with the Lag Bolts (15) and the Large Flat Washers (16) at the drill points. Tighten the bolts firmly, but be careful not to over-tighten.

Assembly Instructions

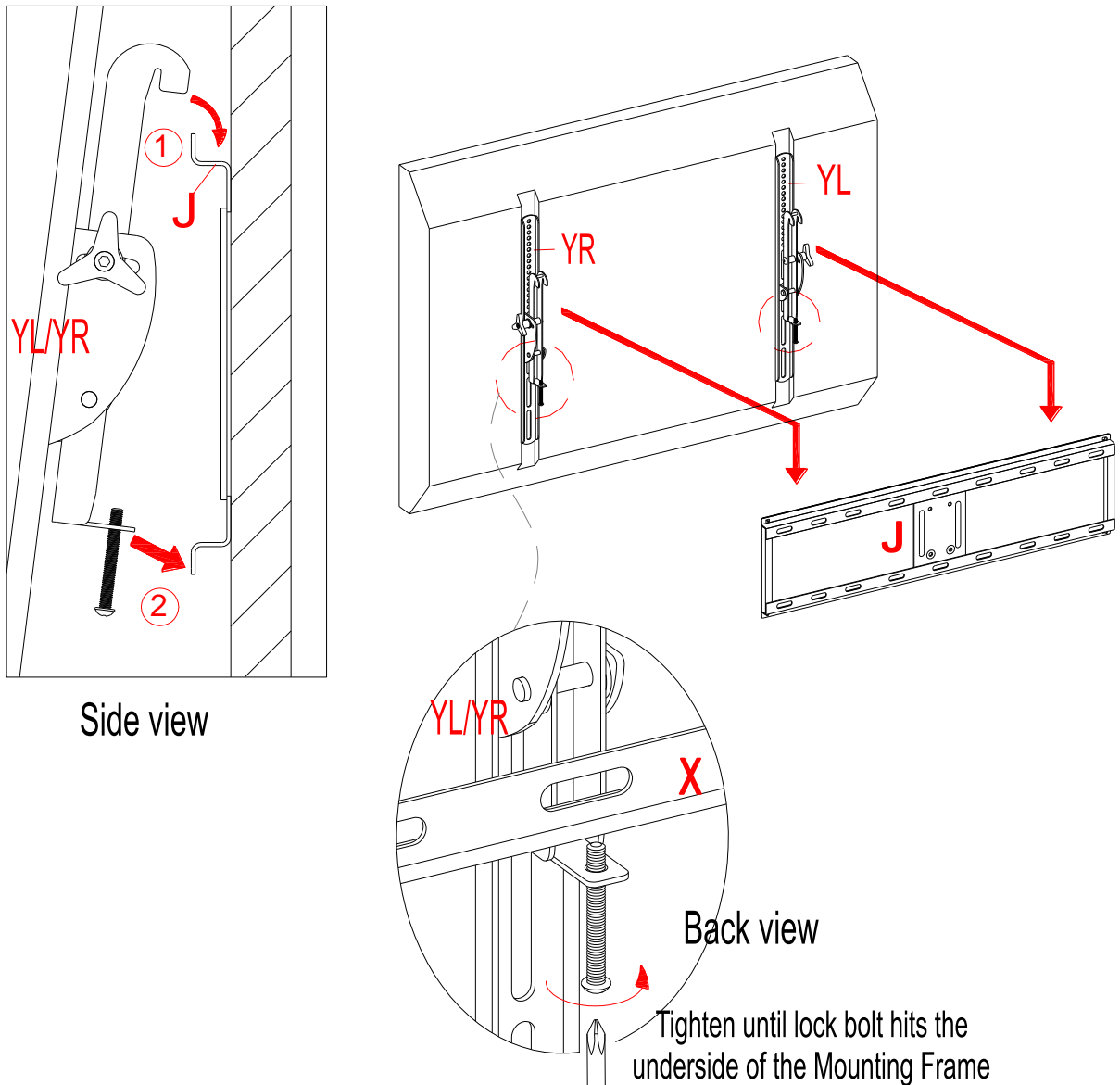

50. Attach the Monitor Brackets (YL/YR) to the back of the television following steps 34 and 35, or 36 and 37, depending on the type of TV that you own.
51. Ask for assistance to lift the television up to attach the Monitor Brackets onto the Mounting Frame (X). Set the hooks on Monitor Brackets over the Mounting Frame and then lower them onto the bars of the Mounting Frame. Proceed to center the television.
52. When the TV is in its intended position, tighten both Lock Bolts with a long Phillips screwdriver until they hit the underside of the Mounting Frame to ensure your TV is safe and secure.
53. Place the assembled Stand under your TV. Finally, connect the A/V and power cables to your TV. You are now ready to enjoy your wall-mounted Flat Panel TV.

Care and Maintenance

- Use a soft, clean cloth that will not scratch the surface when dusting.
- Use of furniture polish is not necessary. Should you choose to use polish, test first in an inconspicuous area.
- Using solvents of any kind on your furniture may damage the finish.
- Never use water to clean your furniture as it may cause damage to the finish.
- Always use coasters under beverage glasses and flowerpots.
- Liquid spills should be removed immediately. Using a soft, clean cloth, blot the spill gently. Avoid rubbing.
- Always use protective pads under hot dishes and plates. Heat can cause chemical changes that may create spotting within the furniture finish.
- In the event that your furniture is stained or otherwise damaged during use, we recommend that you call a professional to repair your furniture.
- Check bolts/screws periodically and tighten them if necessary.

Further Advice about Furniture Care

It is best to keep your furniture in a climate-controlled environment. Extreme temperature and humidity changes can cause fading, warping, shrinking and splitting of wood. It is advised to keep furniture away from direct sunlight as sun may damage the finish.

Proper care and cleaning at home will extend the life of your purchase. Follow these important and helpful tips that will enhance your furniture as it ages.

A touch-up pen has been provided to minimize the small nicks or scratches that may occur during assembly or shipping.

We hope you enjoy your purchase for many years.

Thank you for your purchase!

QUALITY GUARANTEE

We are confident that you will be delighted with your Whalen Furniture purchase.

Should this product be defective in workmanship or materials or fail under normal use, we will repair or replace it for up to one (1) year from date of purchase. Every Whalen Furniture product is designed to meet your highest expectations. We guarantee that you will immediately see the value of our fine furniture.

This warranty gives you specific legal rights and you may also have other rights which vary from State to State.

Customer Service: 866-942-5362

8:30 a.m. - 4:30 p.m., PST, Monday to Friday

www.whalenstyle.com

Estante moderno para televisor 3 en 1 Lana

Serie # BH47-084-899-01

Patente de U.S. 9,215,927

Esté producto está diseñado para ser una configuración 3-en-1. Por favor escoja la opción que mejor sirva a sus necesidades. NO tire el material de ferretería o partes que no usara para la opción escogida. Esto permitirá que usted use esta consola de TV en diferentes configuraciones después, si lo desea.

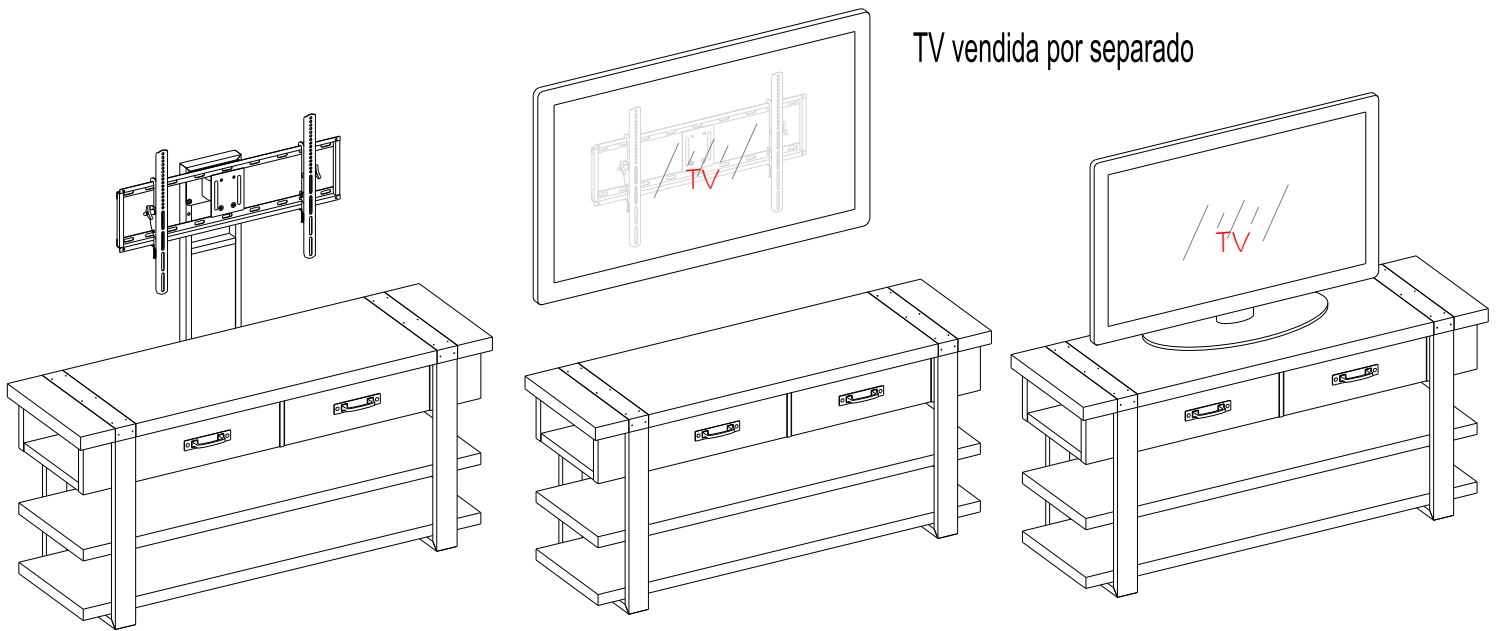

Marco flotador

Montaje en pared

Consola tipo mesa

ENSAMBLE REQUERIDO POR ADULTO

Si tiene alguna pregunta acerca del ensamble o si alguna parte está faltante, no retorne este producto a la tienda donde lo compró. Por favor llame a nuestro departamento de ayuda al cliente teniendo su instructivo y lista de partes para proveer el modelo, nombre de parte o el número de fábrica:

866-942-5362

Hora estándar del Pacífico: 8:30 a.m. - 4:30 p.m., de Lunes a Viernes

O visite nuestra página de Internet 24 horas al día, 7 días a la semana para asistencia

www.whalenstyle.com

O mande un correo electrónico a parts@whalenfurniture.com

**ESTE INSTRUCTIVO CONTIENE INFORMACION IMPORTANTE DE SEGURIDAD.
POR FAVOR LEA Y MANTENGA PARA USO FUTURO.**

Fecha 2018-08-20

Rev. 0001-B

MÁXIMOS PESOS RECOMENDADOS

FABRICANTE: Whalen Furniture Manufacturing
CATALOGO: Estante moderno para televisor 3 en 1 Lana
MODELO # BH47-084-899-01
HECHO EN CHINA

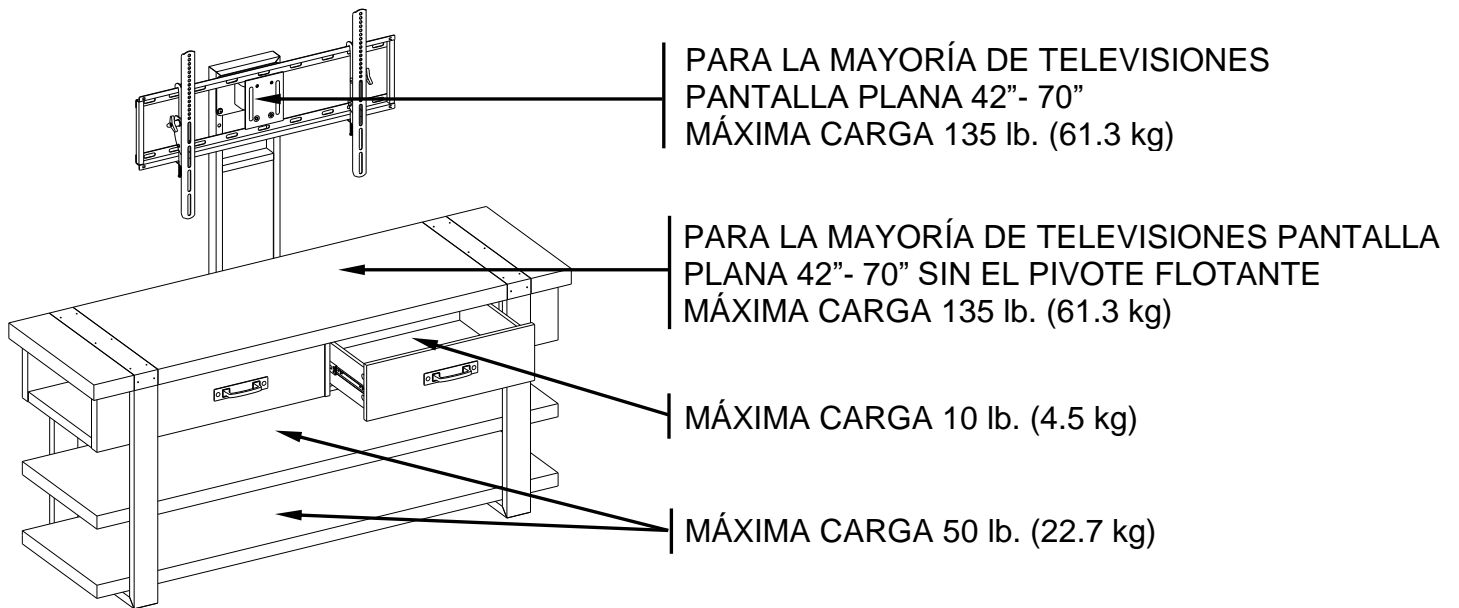

ADVERTENCIA

ESTA UNIDAD NO DEBE UTILIZARSE CON TELEVISIONES CRT O DE TUBO. UTILIZARSE ÚNICAMENTE CON TELEVISIONES DE PANTALLA PLANA Y EQUIPO DE AUDIO/VIDEO QUE TENGA LA MEDIDA/PESO RECOMENDADO. NUNCA UTILIZAR CON TELEVISIONES MÁS GRANDES/PESADAS DE LAS RECOMENDADAS. PARA EVITAR INESTABILIDAD COLÓQUELA EN EL CENTRO DE LA UNIDAD; LA BASE DE LA TELEVISIÓN DEBE DE REPOSAR SOBRE LA SUPERFICIE DE SOPORTE DE LA UNIDAD SIN REBASAR LAS ORILLAS. LAS TELEVISIONES DE PANTALLA PLANA COLOCADAS INAPROPIADAMENTE, O LAS TELEVISIONES DE PANTALLA PLANA INCLUYENDO EQUIPO QUE SOBREPASA LAS MEDIDAS Y PESOS RECOMENDADOS PUEDEN CAERSE Y/O ROMPER LA UNIDAD, CAUSANDO POSIBLES DAÑOS O LESIONES.

INFORMACION GENERAL, RECOMENDACIONES Y TRUCOS

1. Por favor lea el instructivo antes de comenzar el ensamble.
2. Retirar todo el material de ferretería de la caja y acomodar por medida.
3. Revisar que todo el material de ferretería y partes estén completos ANTES de comenzar el ensamble.
4. Pida ayuda a un amigo para ensamblar esta unidad.
5. Para evitar daños, ensamble esta unidad en un área fuerte, nivelada y protegida.
6. Espere que todos los pasos se terminen antes de apretar todos los pernos por completo.
7. Asegúrese que todos los pernos estén bien apretados antes de utilizar la unidad.

Este producto se vende con un juego de restricción de movimiento. Usted debe instalar este juego entre su pared y la consola para prevenir accidentes o daños. Cuando se instala apropiadamente, este puede proteger contra caída inesperadas de la consola debido a temblores, golpes o en caso de subirse en ella. Este juego sirve solo como un impedimento y no sustituye la supervisión por parte de un adulto. El uso de este tipo de topes puede prevenir, pero no eliminar, la posibilidad de que la unidad se caiga o se incline.

IMPORTANTE

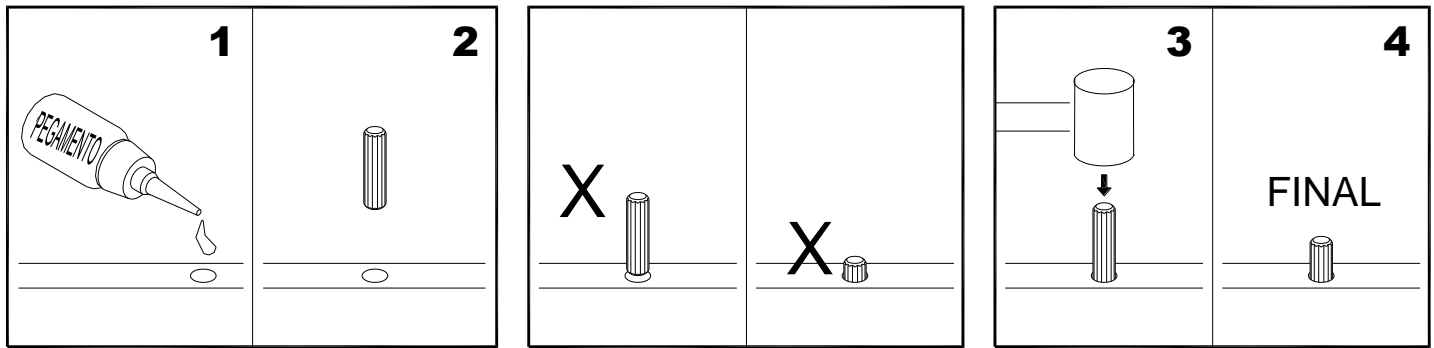

Antes de comenzar: Abra, identifique y cuente todas las partes antes del ensamble. Coloque las piezas sobre una superficie plana y no abrasiva. Tendrá las partes identificadas en la página 4 de este manual de instrucciones.

NOTA: ES MUY IMPORTANTE EL USO DE GOMA CON LAS CLAVIJAS DE MADERA. EL EXCESO DE PEGAMENTO SE PUEDE LIMPIAR CON UN PAÑO HÚMEDO.

Inserte la clavija por lo menos a la mitad del camino golpeando ligeramente con un mazo de goma, SI ES NECESARIO.

SISTEMA DE OPERACIÓN DE TUERCA DE FIJACIÓN

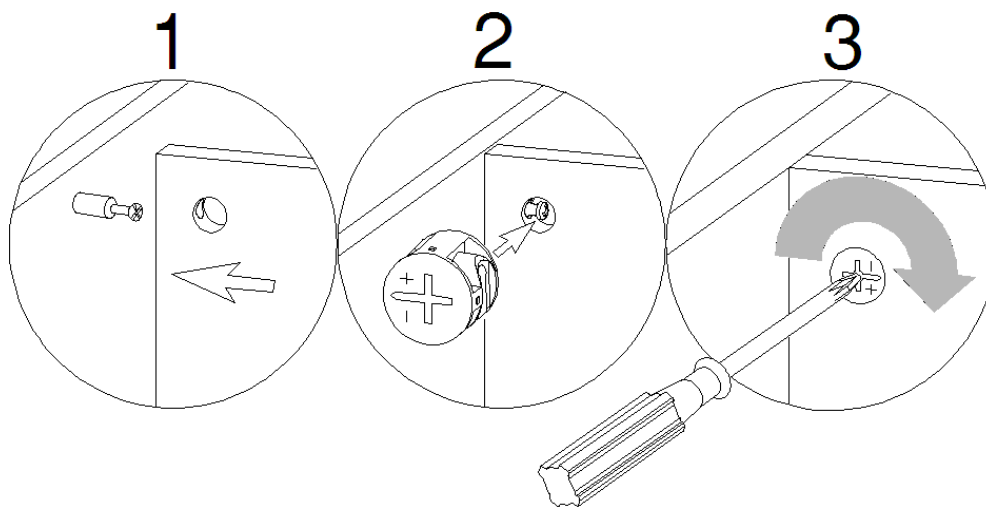

CÓMO FUNCIONA LA INSTALACIÓN DE MONTAJE (KD)

1. Fijar los pernos de fijación en los orificios pequeños. Conectar ambos paneles, cerciorándose que los pernos de fijación entren bien y que estos queden en los orificios al final del panel con tuercas de fijación.
2. Inserte las tuercas de fijación en los orificios grandes del panel. Hacer que la flecha en la tuerca este apuntando hacia la entrada del perno de fijación.
3. Una vez que el perno esté conectado dentro, tome un destornillador de cruz y apriete la tuerca en dirección de las manecillas del reloj.

Está listo para el ensamble KD de esta unidad.

Lista de partes y material de ferretería

Por favor lea completamente las instrucciones y verifique que estén todas las partes antes de iniciar el ensamblado.

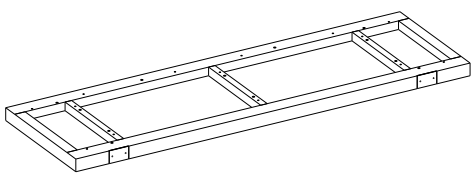

A- Panel superior
(Cant. 1)

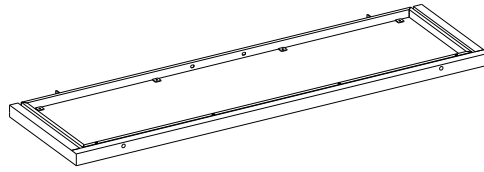

B- Repisa inferior con marco de metal
(Cant. 2)

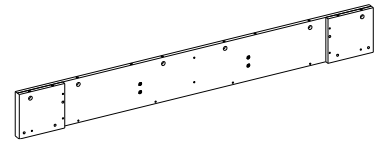

C- Panel posterior de la caja cajón
(Cant. 1)

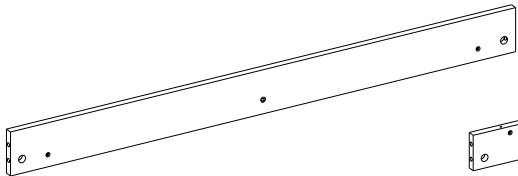

D- Soporte frontal (Cant. 1)

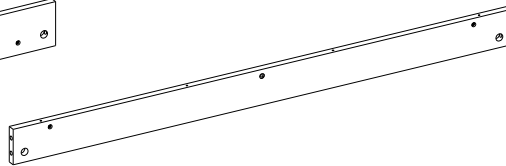

E- Soporte posterior (Cant. 1)

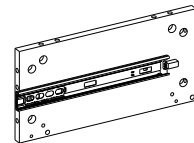

F- Lado izquierdo de la caja cajón (Cant. 1)

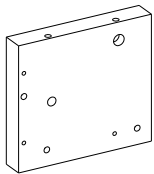

G- Frente izquierdo de la caja cajón
(Cant. 1)

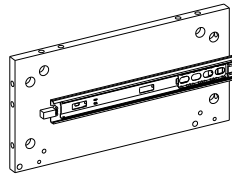

H- Lado derecho de la caja cajón
(Cant. 1)

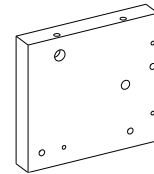

I- Frente derecho de la caja cajón
(Cant. 1)

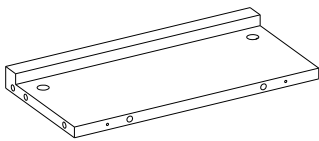

J- Repisa fija (Cant. 2)

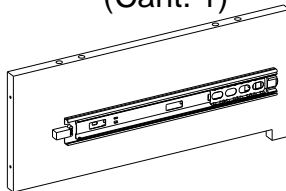

K- Panel divisor (Cant. 1)

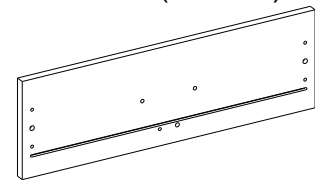

L- Frente del cajón (Cant. 2)

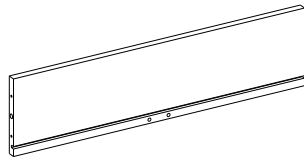

M- Panel posterior del cajón
(Cant. 2)

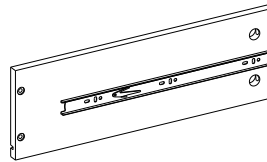

N- Lado izquierdo del cajón
(Cant. 2)

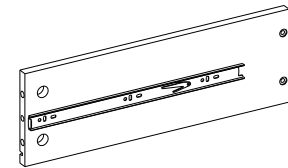

O- Lado derecho del cajón
(Cant. 2)

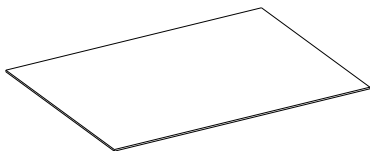

P- Panel inferior del cajón (Cant. 2)

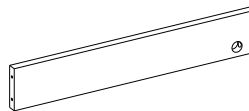

Q- Soporte inferior del cajón (Cant. 2)

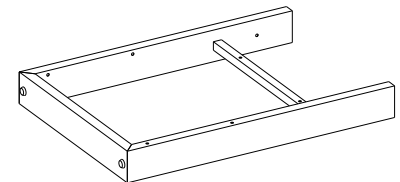

R- Pata izquierda (Cant. 1)

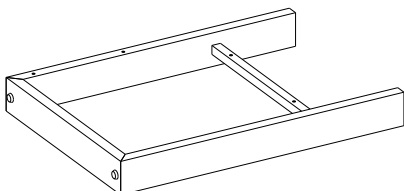

S- Pata derecha (Cant. 1)

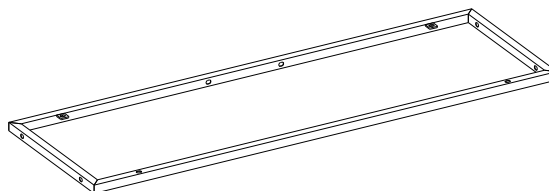

T- Marco de metal superior (Cant. 1)

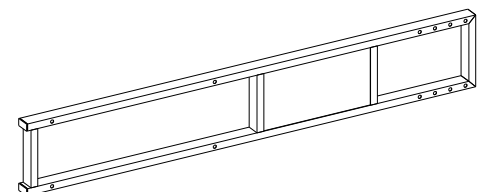

U- Poste largo (Cant. 1)

Lista de partes y material de ferretería

Por favor lea completamente las instrucciones y verifique que estén todas las partes antes de iniciar el ensamblado.

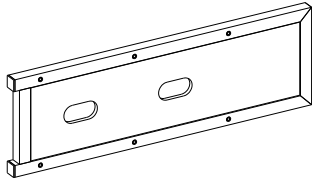

V- Marco posterior (Cant. 1)

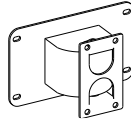

W- Soporte del pivote (Cant. 1)

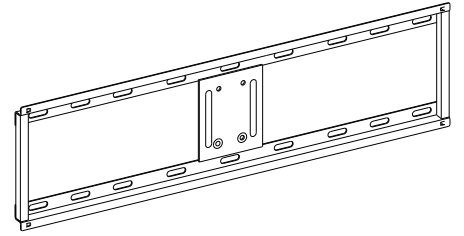

X- Marco de montaje (Cant. 1)

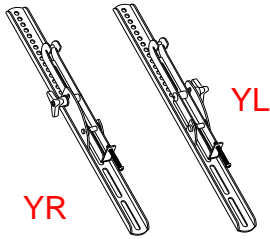

Y- Soporte de monitor (Cant. 2)

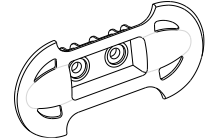

Z- Guía de cable (Cant. 2)



(1) Tuerca de fijación chica
(Cant. 10+1 extra)



(2) Tuerca de fijación grande
(Cant. 30+1 extra)

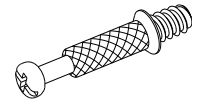

(3) Perno de fijación
(Cant. 40+2 extra)

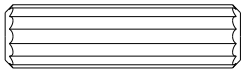

(4) Clavija de madera de M8 x 30 mm
(Cant. 34+1 extra)

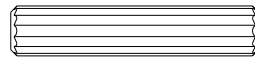

(5) Clavija de madera de M6 x 30 mm
(Cant. 10+1 extra)

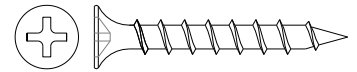

(6) Perno de M4 x 32 mm
(Cant. 24+1 extra)

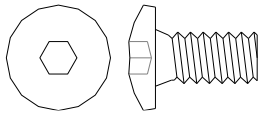

(7) Perno de 1/2" (4+1 extra)

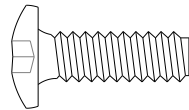

(8) Perno de 3/4" (10+1 extra)

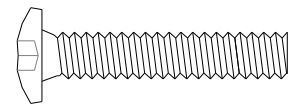

(9) Perno de 1-1/4" (12+1 extra)

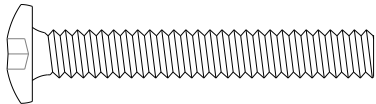

(10) Perno de 1-3/4"
(Cant. 2+1 extra)

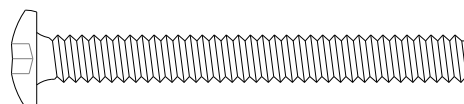

(11) Perno de 2-1/4"
(Cant. 8+1 extra)

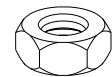

(12) Tuerca hexagonal
(Cant. 4+1 extra)



(13) Arandela de presión
(Cant. 40+2 extra)

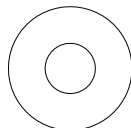

(14) Arandela plana
(Cant. 40+2 extra)

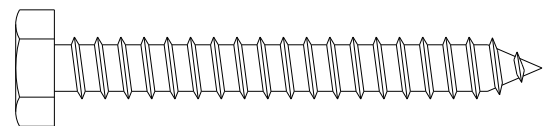

(15) Perno especial de 2-1/2"
(Cant. 4)

Lista de partes y material de ferretería

Por favor lea completamente las instrucciones y verifique que estén todas las partes antes de iniciar el ensamblado.

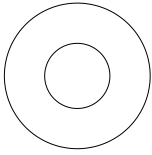

(16) Arandela plana grande
(Cant. 4+1 extra)

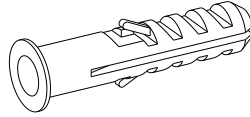

(17) Ancla para concreto
(Cant. 4)

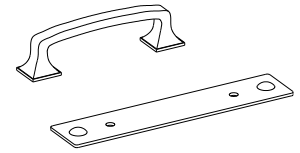

(18) Manija y placa posterior
(Cant. 2)

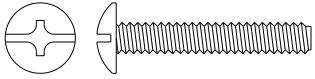

(19) Perno de manija
(Cant. 4)

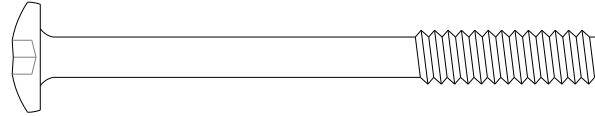

(20) Perno de 2-5/8"
(Cant. 4+1 extra)

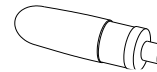

Pegamento
(Cant. 1)

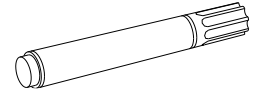

Plumón de retoque
(Cant. 1)



Llave española
(Cant. 1)

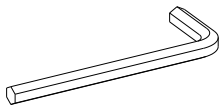

Llave hexagonal de 4 mm
(Cant. 1)

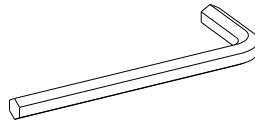

Llave hexagonal de 3/16"
(Cant. 1)

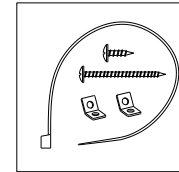

Juego de restricción de movimiento (Cant. 1)
(Incluido en bolsa de plástico)

Juego de montaje

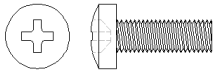

Perno de M4 x 12mm
(Cant. 4)



Perno de M4 x 30mm
(Cant. 4)

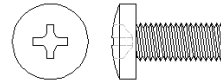

Perno de M5 x 12mm
(Cant. 4)

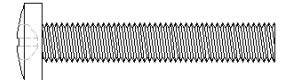

Perno de M5 x 30mm
(Cant. 4)

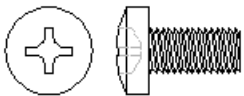

Perno de M6 x 12 (Cant. 4)

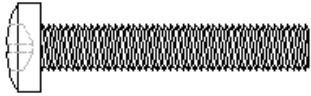

Perno de M6 x 35 (Cant. 4)

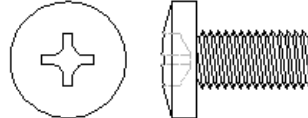

Perno de M8 x 16 (Cant. 4)

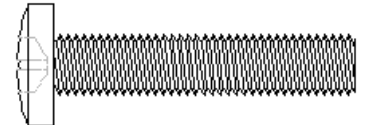

Perno de M8 x 40 (Cant. 4)



Arandela estrella M4
(Cant. 4)



Arandela estrella M5
(Cant. 4)

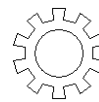

Arandela estrella M6
(Cant. 4)

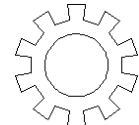

Arandela estrella M8
(Cant. 4)



Espaciador largo
(Cant. 4)



Espaciador corto
(Cant. 4)

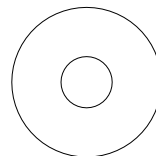

Arandela plana de M4/M5
(Cant. 8)

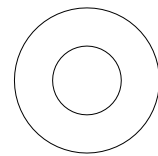

Arandela plana de M6/M8
(Cant. 4)

Herramientas Requeridas: Llave hexagonal, llave española (proveida) y desarmador estrella (no proveido).

Ensamble del cajón

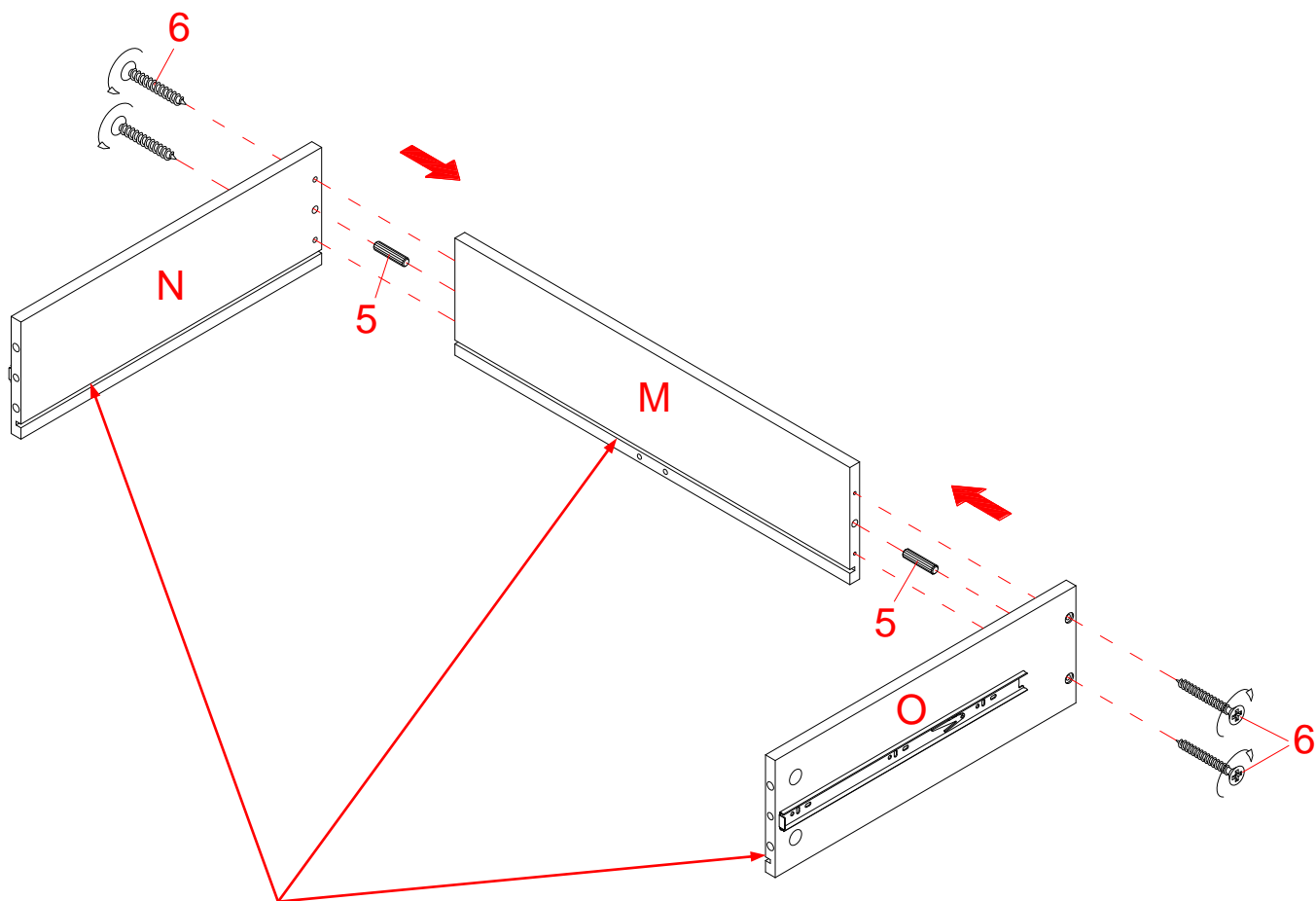

Las ranuras se alinean la una con la otra y apuntan hacia adentro

Clavija de madera de
M6 x 30 mm
(2 usados en este paso)

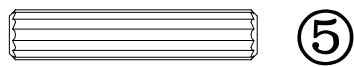

Perno de M4 x 32 mm
(4 usados en este paso)

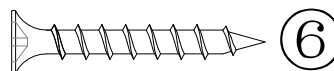

1. Desempacar la unidad y confirmar que se tiene todo el material de ferretería y partes requeridas.
2. Sujetar un panel posterior del cajón (M) entre los paneles izquierdo y derecho del cajón (N y O) con 4 pernos de 32 mm (6) y 2 clavijas de madera de M6 x 30 mm (5).

NOTA: Es muy importante usar una cantidad pequeña de goma en ambos lados de la clavija.

Ensamble del cajón

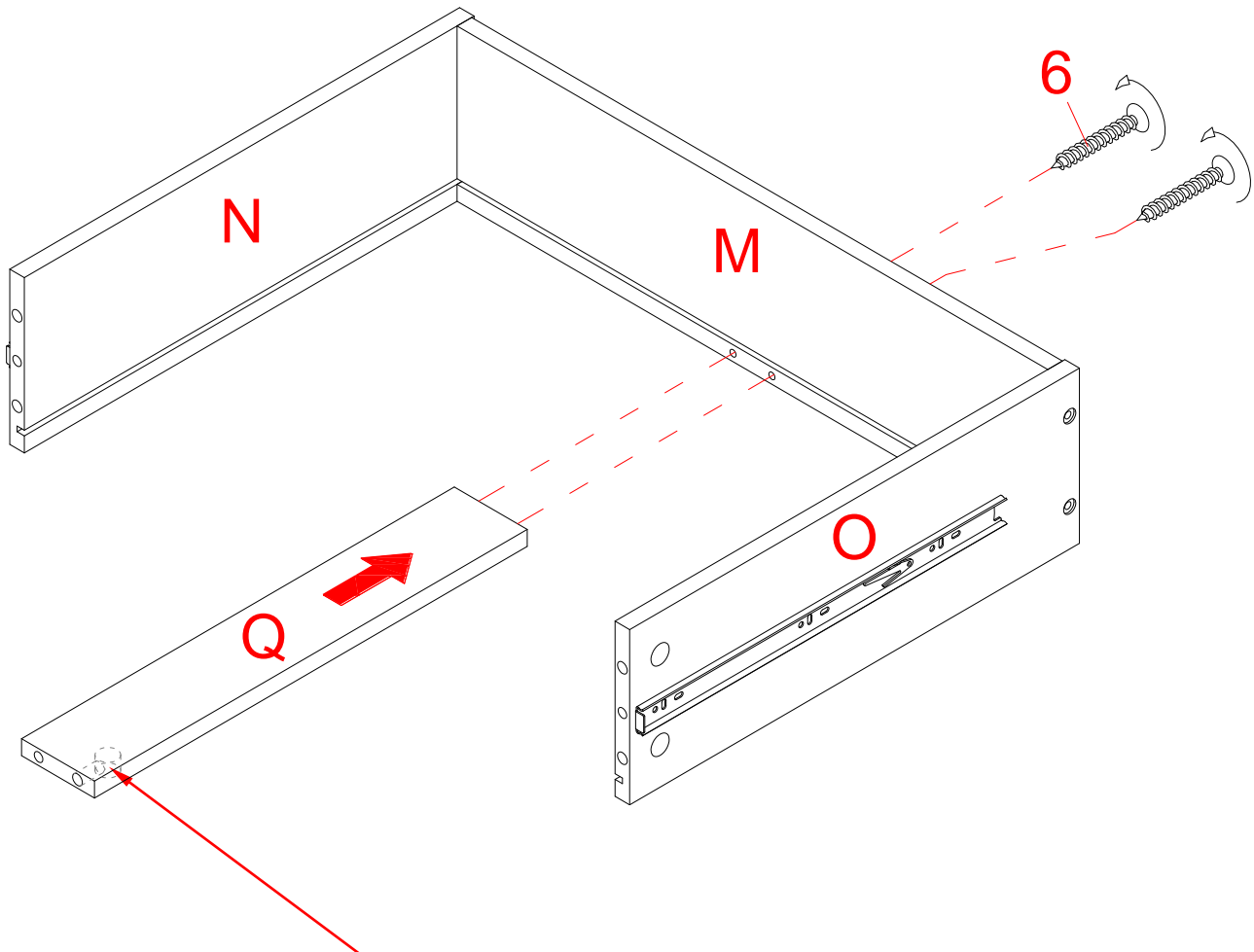

El agujero de la tuerca de fijación en el lado opuesto

Perno de M4 x 32 mm
(2 usados en este paso)

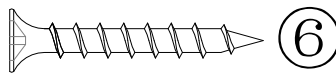

3. Sujetar un soporte inferior del cajón (Q) al panel posterior del cajón (M) con 2 pernos de 32 mm (6).

Ensamble del cajón

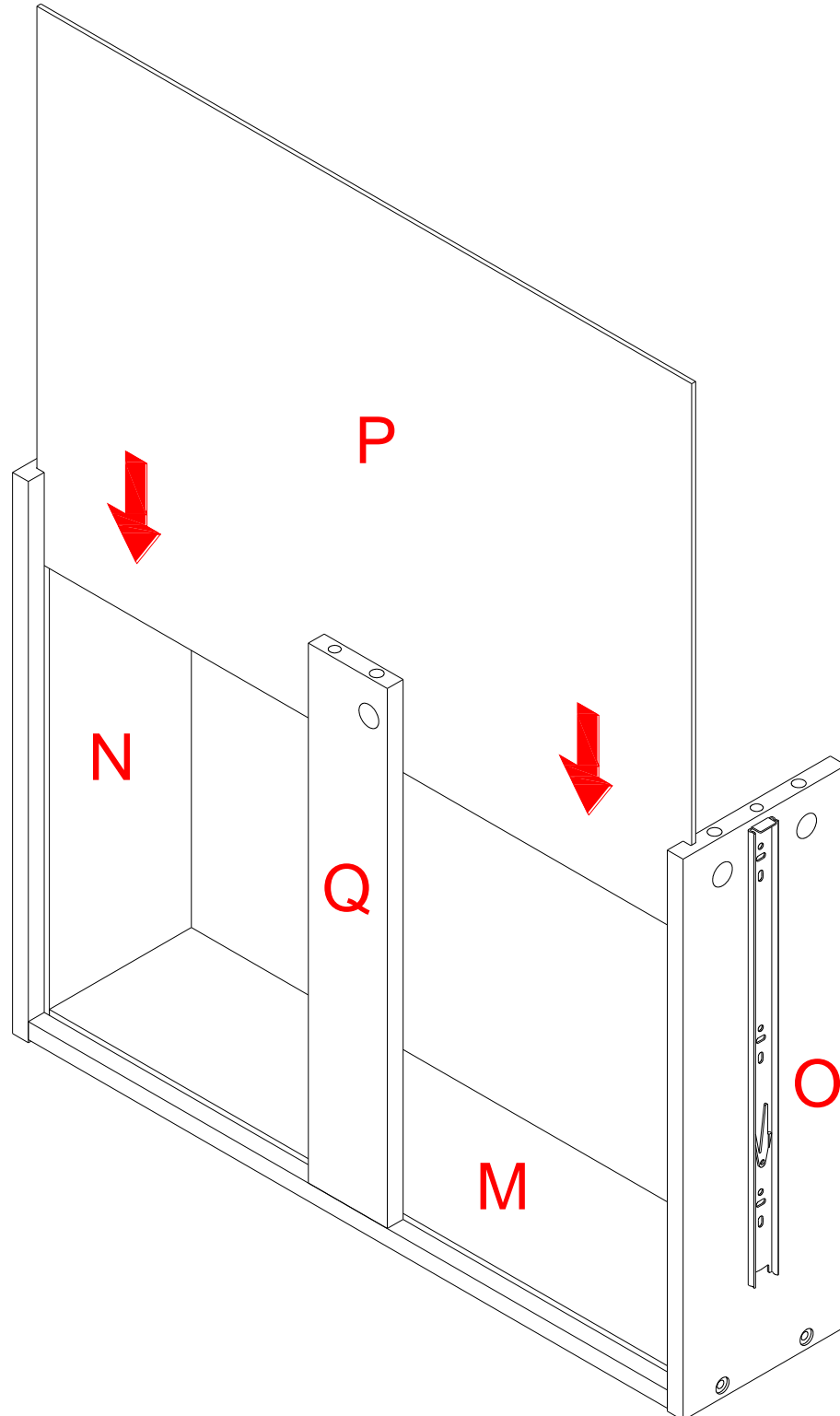

4. Deslizar un panel inferior del cajón (P) en las ranuras entre los paneles izquierdo y derecho del cajón (N y O) hasta que esté completamente insertado en la ranura del panel inferior del cajón (M).

Ensamble del cajón

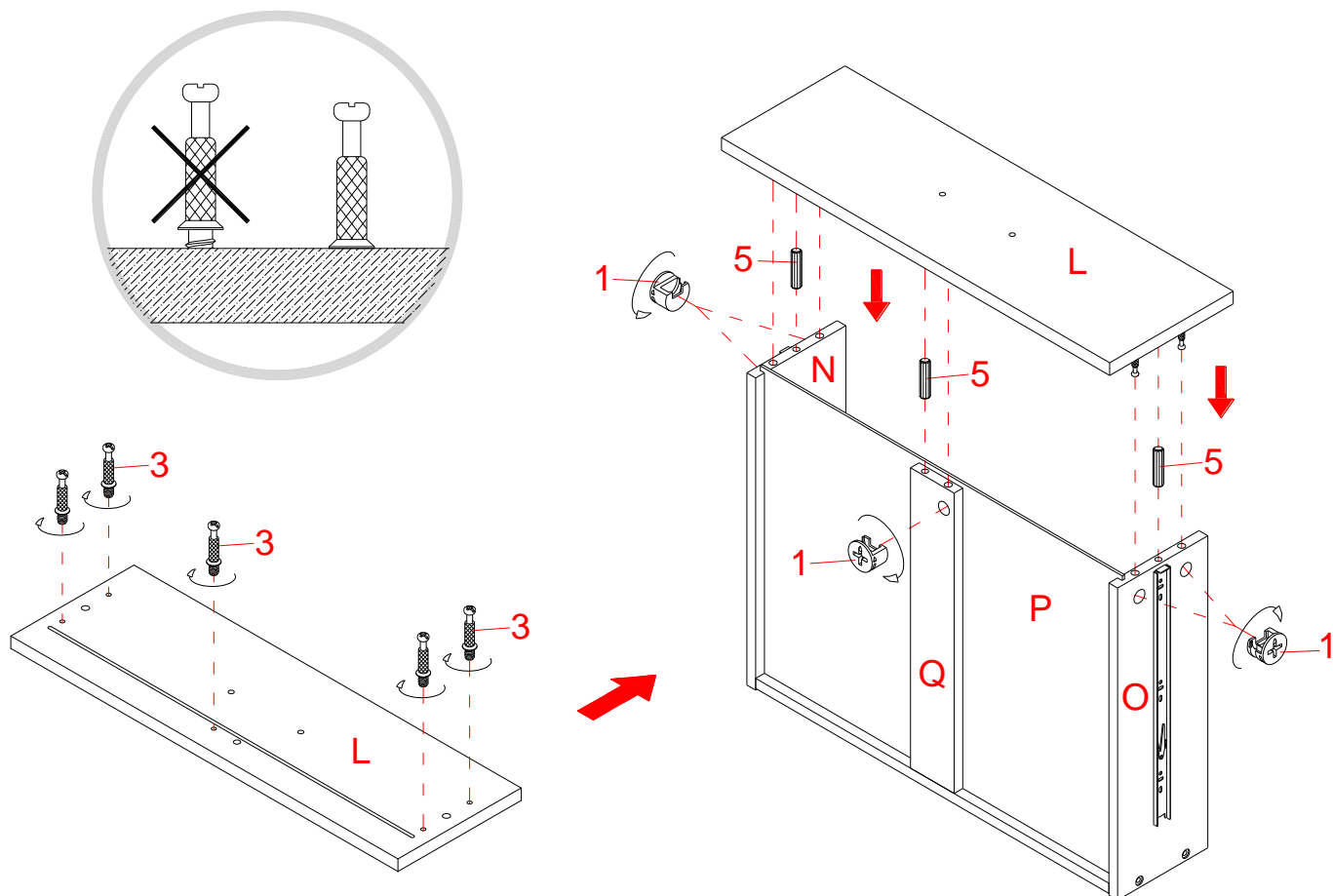

Tuerca de fijación chica
(5 usados en este paso)



①

Perno de fijación
(5 usados en este paso)

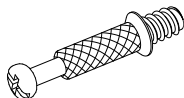

③

Clavija de madera de
M6 x 30 mm
(3 usados en este paso)

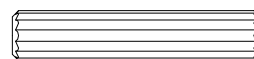

⑤

5. Atornillar 5 pernos de fijación (3) en los agujeros chicos designados en un frente del cajón (L).
6. Sujetar el frente del cajón (L) a los paneles izquierdo y derecho del cajón (N y O) y el soporte inferior del cajón (Q) con 3 clavijas de madera de M6 x 30 mm (5) y 5 tuercas de fijación chica (1) (Consulte la página 3 del sistema de tuerca de fijación). Asegurar de que el panel inferior del cajón (P) encaje en la ranura del frente del cajón (L).

Ensamble del cajón

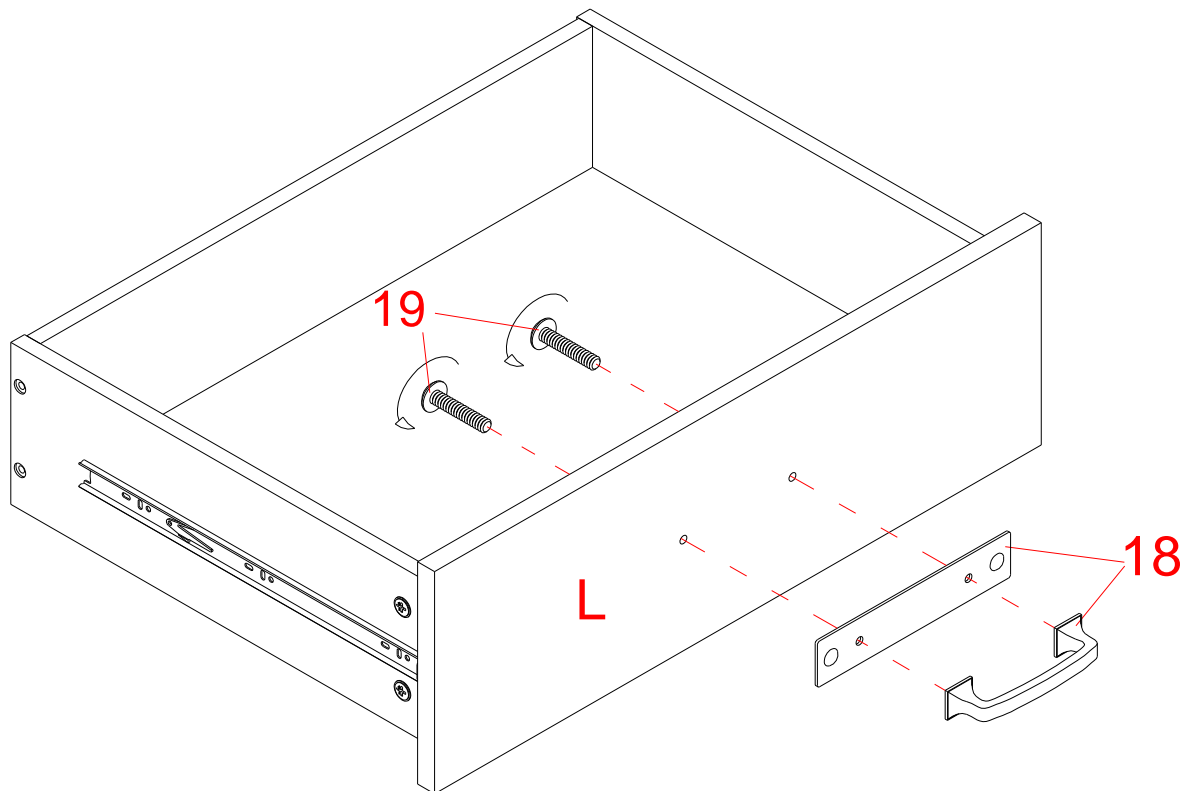

Manija y placa posterior
(1 usado en este paso)

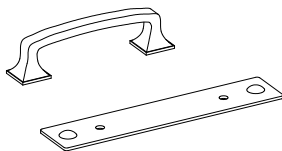

18

Perno de manija
(2 usados en este paso)

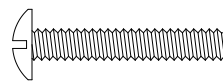

19

7. Voltar el cajón ensamblado en posición vertical. Adjuntar la manija y una placa posterior (18) a lado frontal del frente del cajón (L) con los pernos de manija (19).
8. Repetir el mismo proceso para ensamblar el otro cajón.

Ensamble del cajón

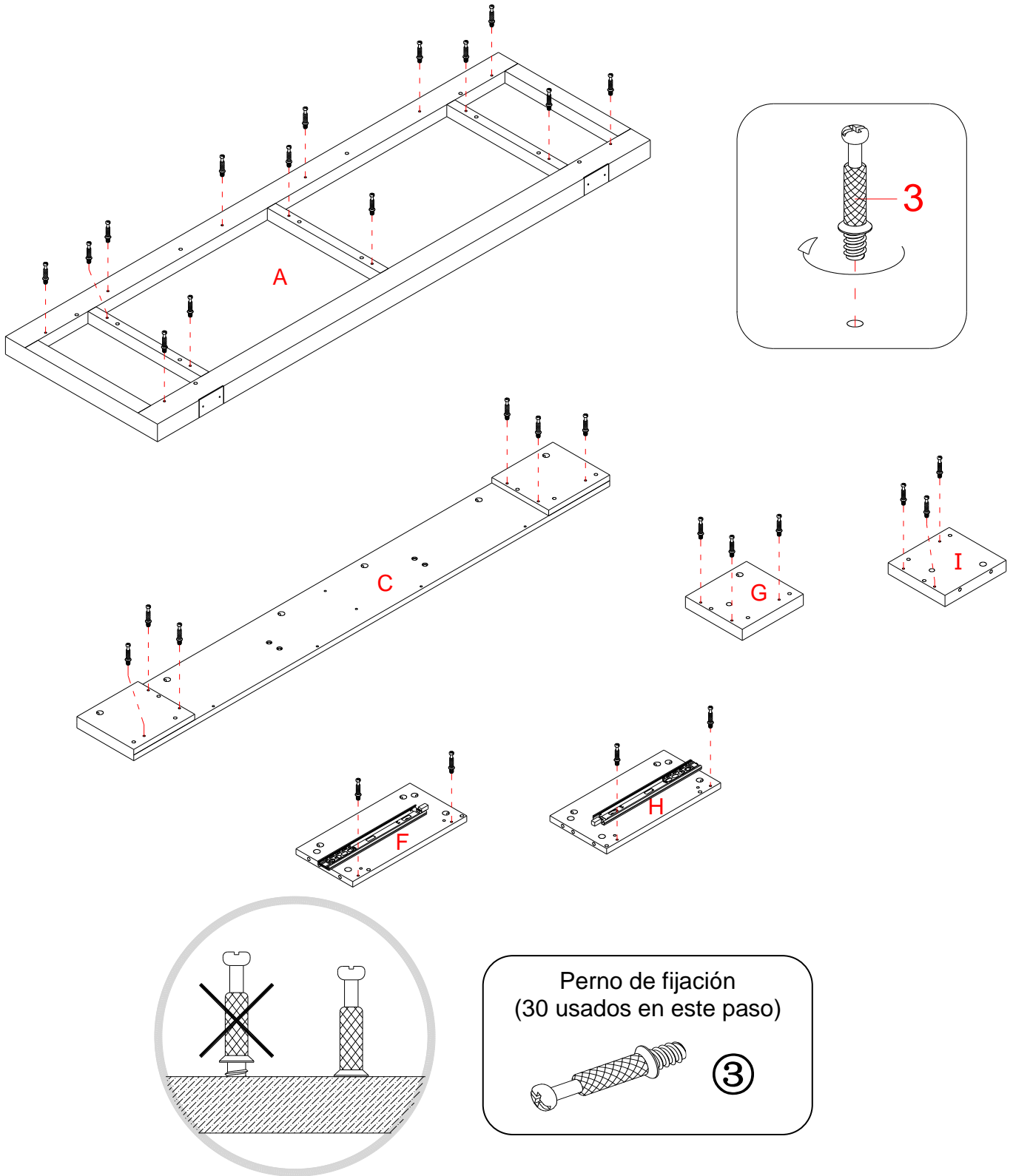

9. Atornillar los pernos de fijación (3) en los agujeros chicos designados en el panel superior (A), en el panel posterior (C), en los paneles laterales de la caja cajón (F y H) y en los paneles frontales de la caja cajón (G y I) usando el desarmador estrella.

Instructivo de ensamble

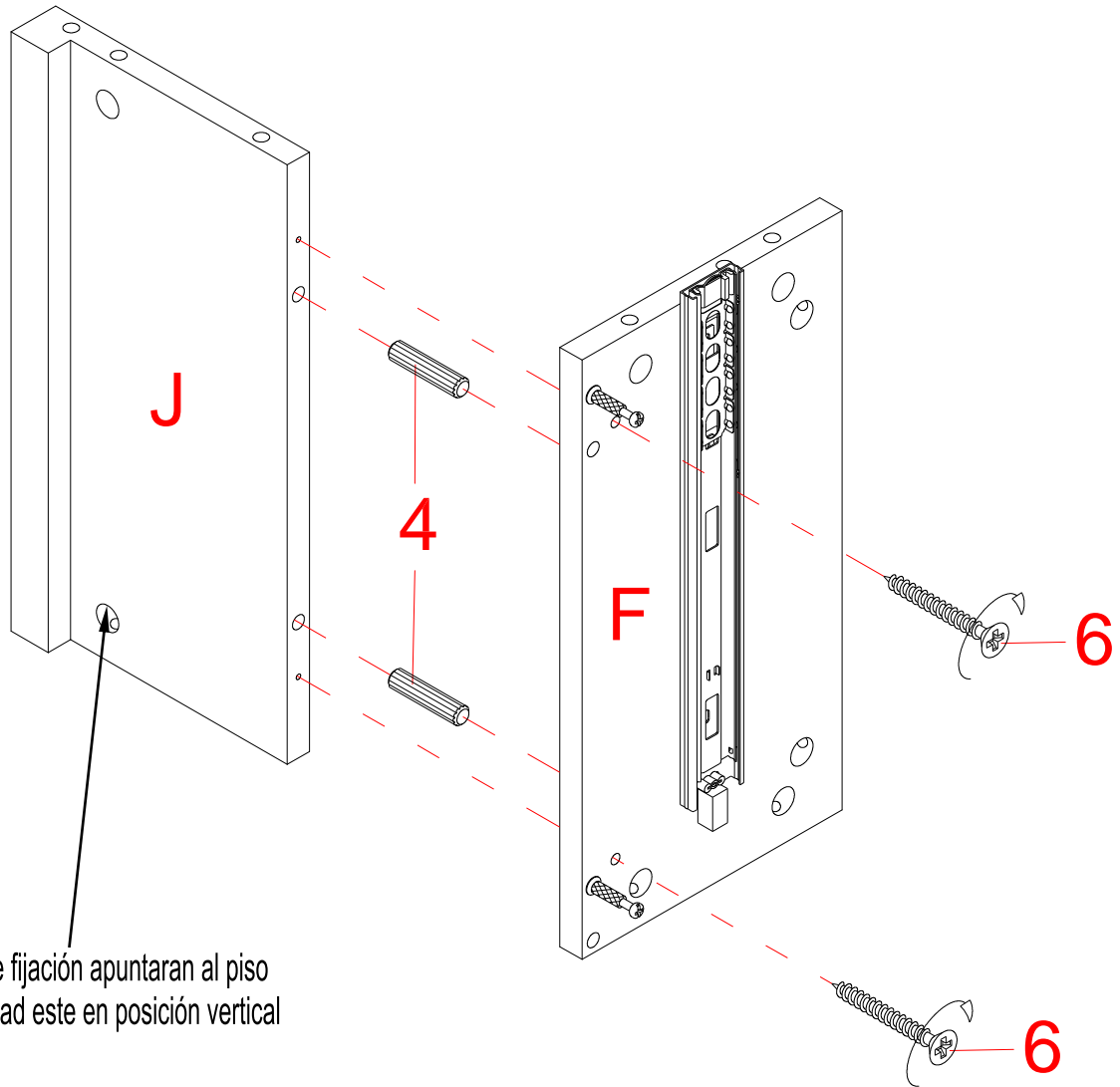

Clavija de madera de
M8 x 30 mm
(2 usados en este paso)

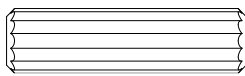

④

Perno de M4 x 32 mm
(2 usados en este paso)

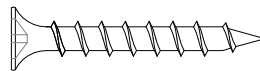

⑥

10. Adjuntar una repisa fija (J) al panel izquierdo de la caja cajón (F) con 2 clavijas de madera de M8 x 30 mm (4) y 2 pernos de 32 mm (6).

Instructivo de ensamble

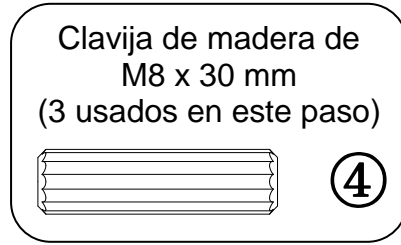
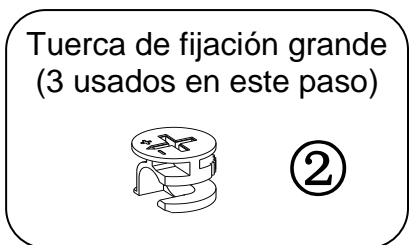
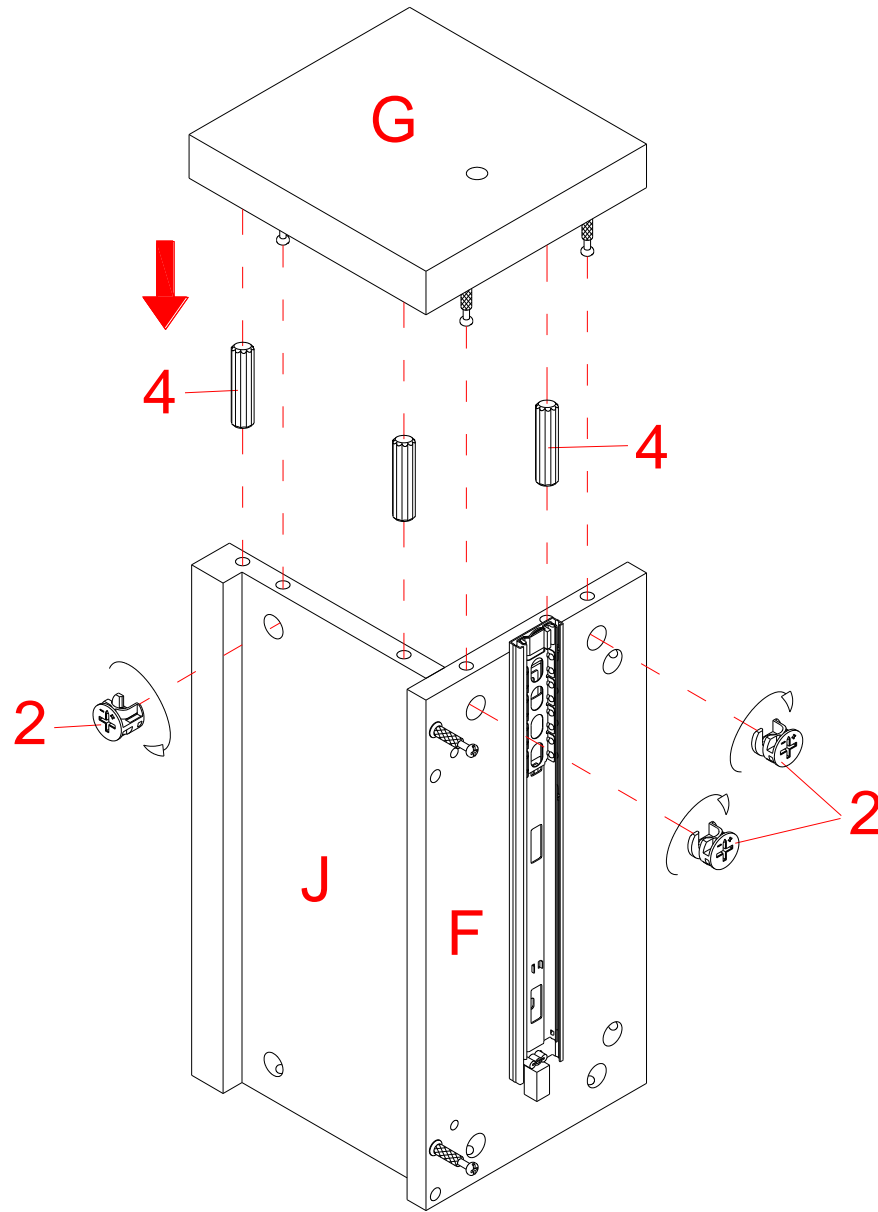

11. Adjuntar el frente izquierdo de la caja cajón (G) a la repisa fija (J) y al panel izquierdo de la caja cajón (F) con 3 tuercas de fijación grandes (2) y 3 clavijas de madera de M8 x 30 mm (4).

Instructivo de ensamble

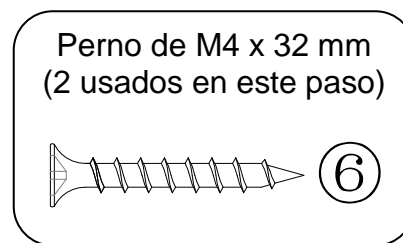
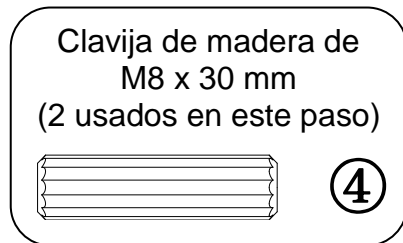
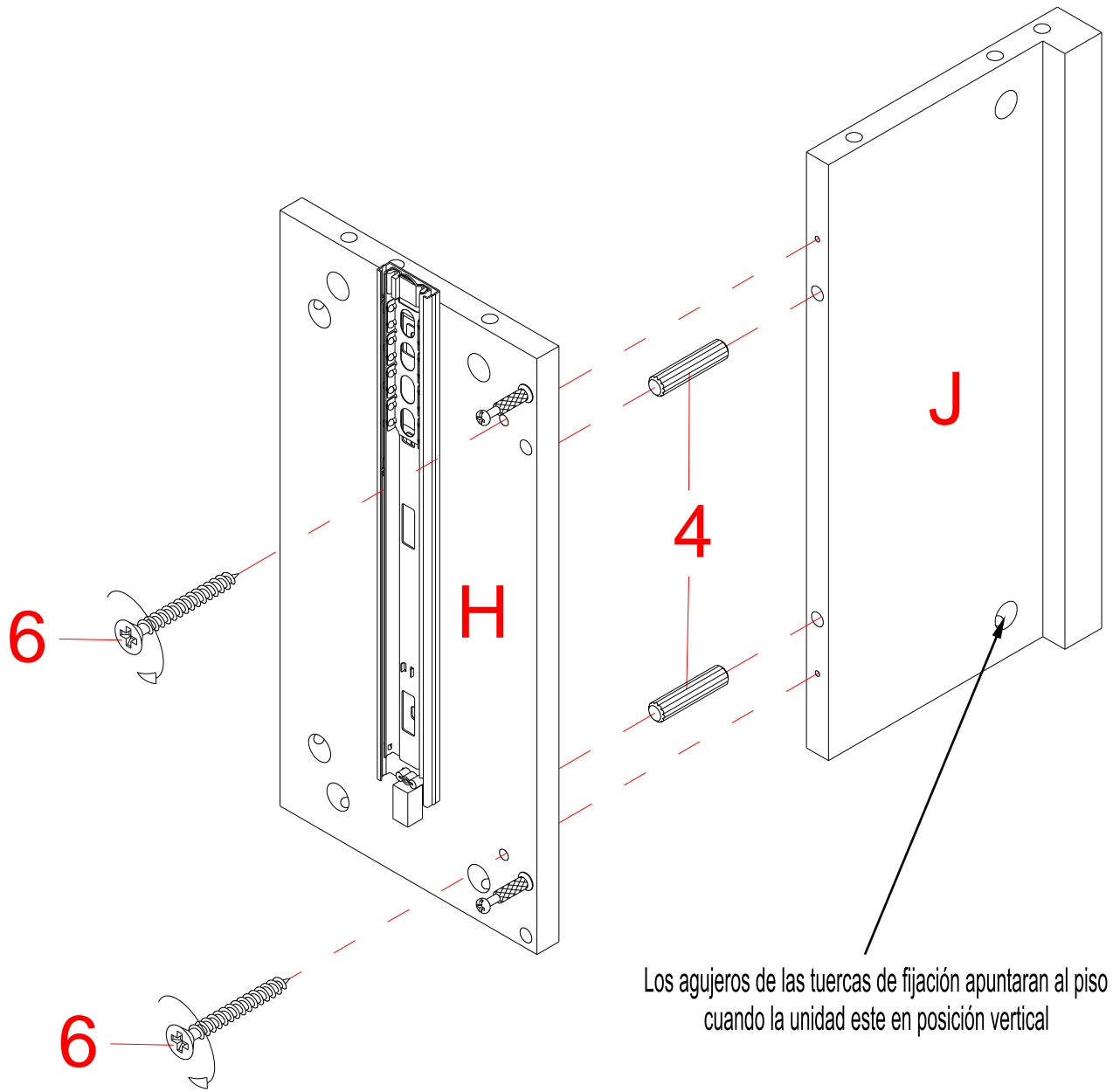

12. Adjuntar la repisa fija (J) al panel derecho de la caja cajón (H) con 2 clavijas de madera de M8 x 30 mm (4) y 2 pernos de 32 mm (6).

Instructivo de ensamble

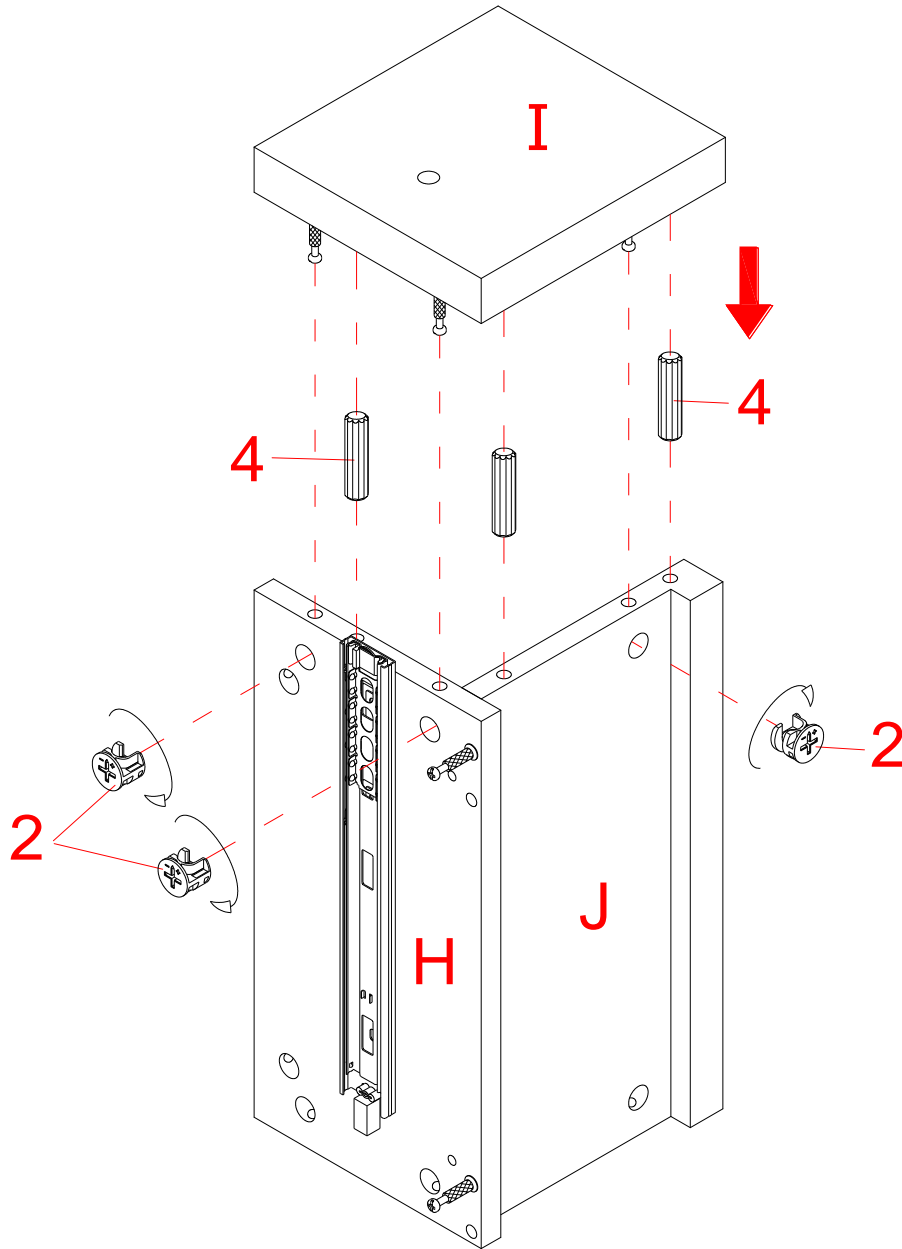

Tuerca de fijación grande
(3 usados en este paso)



②

Clavija de madera de
M8 x 30 mm
(3 usados en este paso)

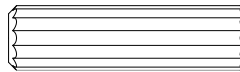

④

13. Adjuntar el frente derecho de la caja cajón (I) a la repisa fija (J) y al panel derecho de la caja cajón (H) con 3 tuercas de fijación grandes (2) y 3 clavijas de madera de M8 x 30 mm (4).

Instructivo de ensamble

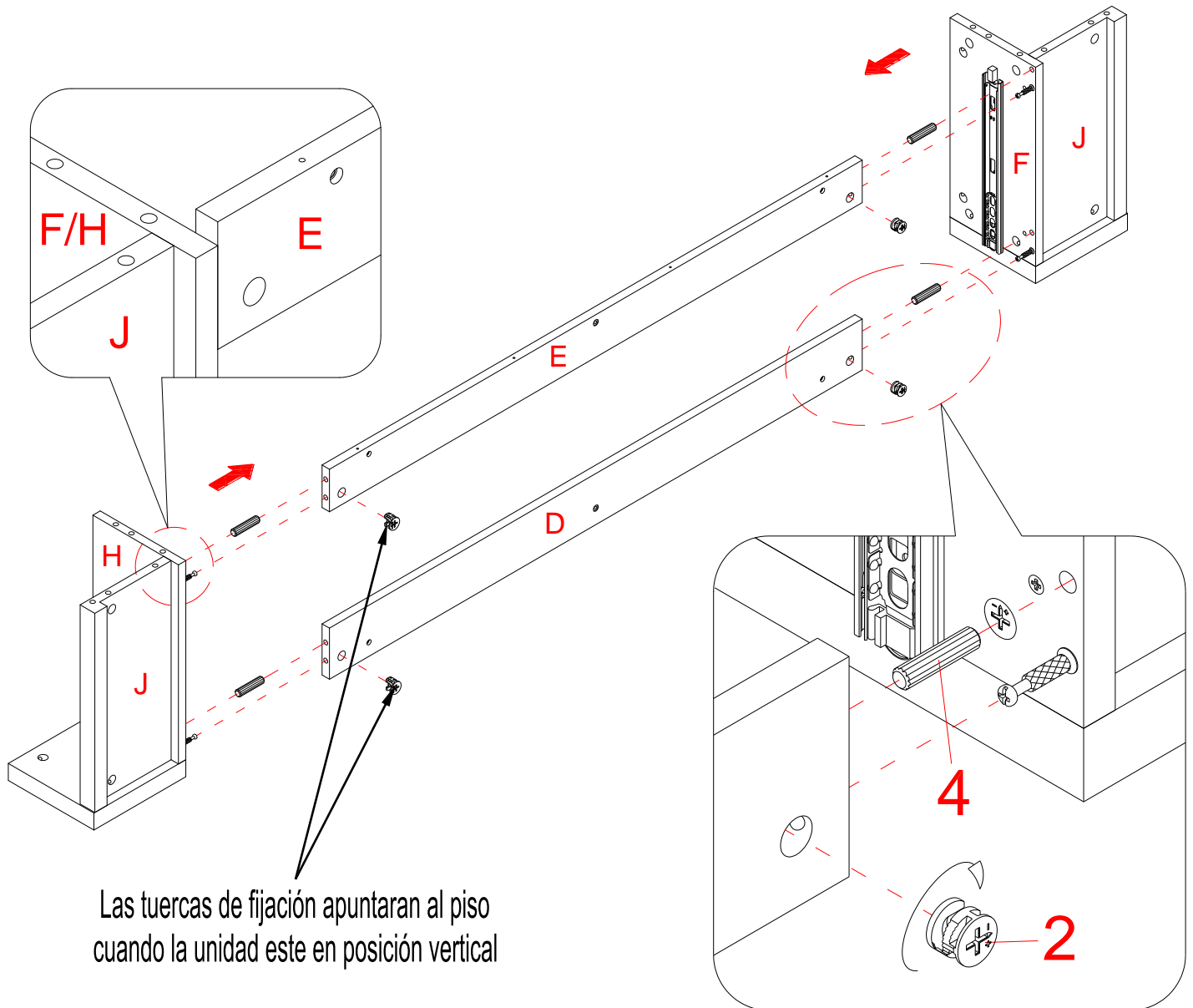

Tuerca de fijación grande
(4 usados en este paso)



②

Clavija de madera de
M8 x 30 mm
(4 usados en este paso)

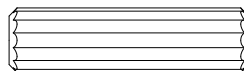

④

14. Adjuntar los soportes frontal y posterior (D y E) entre los paneles laterales de la caja cajón (F y H) con 4 tuercas de fijación grandes (2) y 4 clavijas de madera de M8 x 30 mm (4).

Instructivo de ensamble

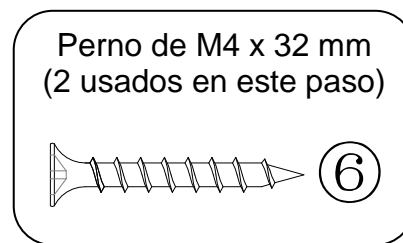
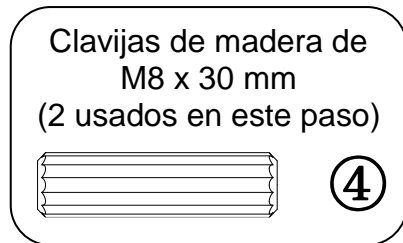
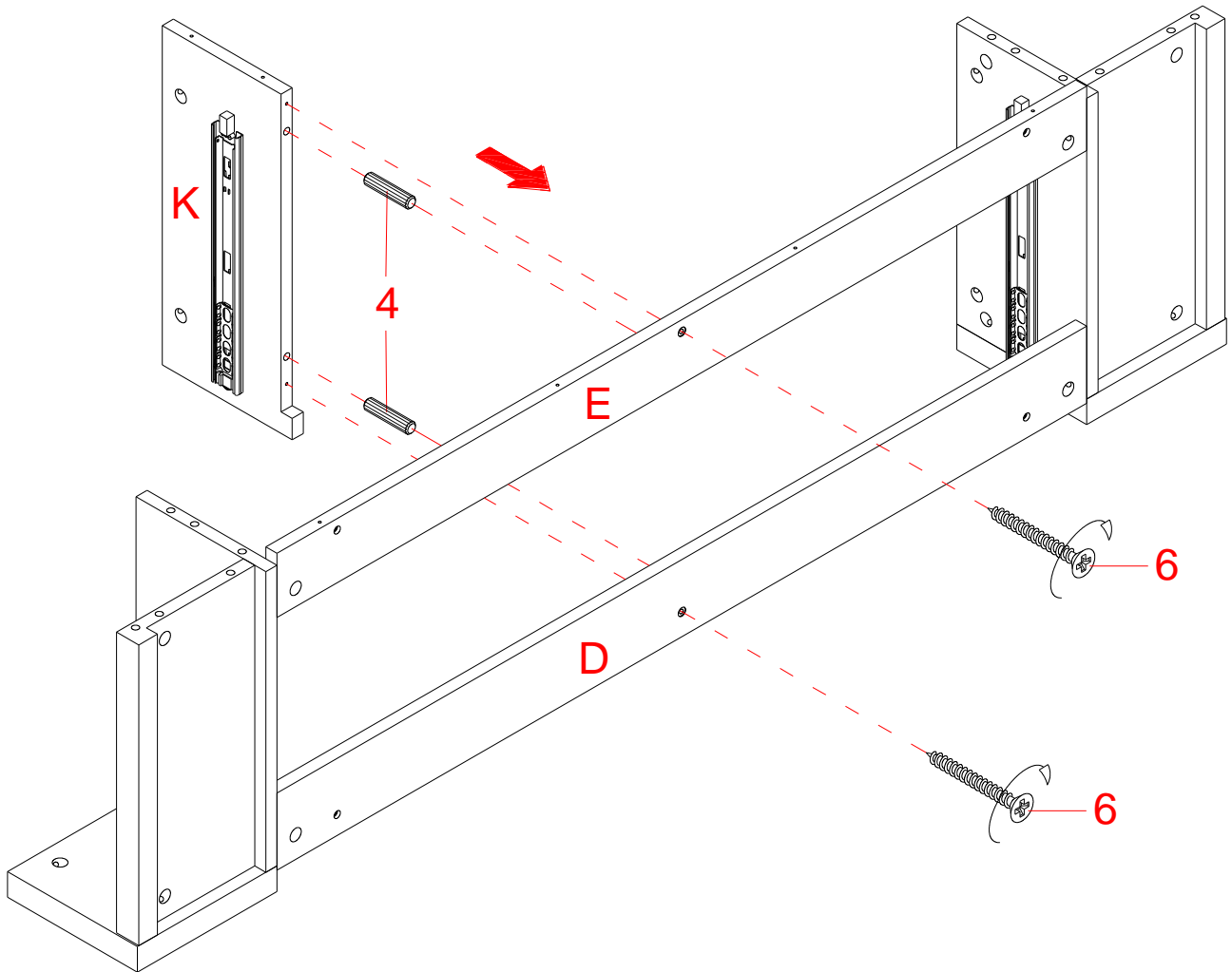

15. Adjuntar el panel divisor (K) a los soportes frontal y posterior (D y E) con 2 clavijas de madera de M8 x 30 mm (4) y 2 pernos de 32 mm (6).

Instructivo de ensamble

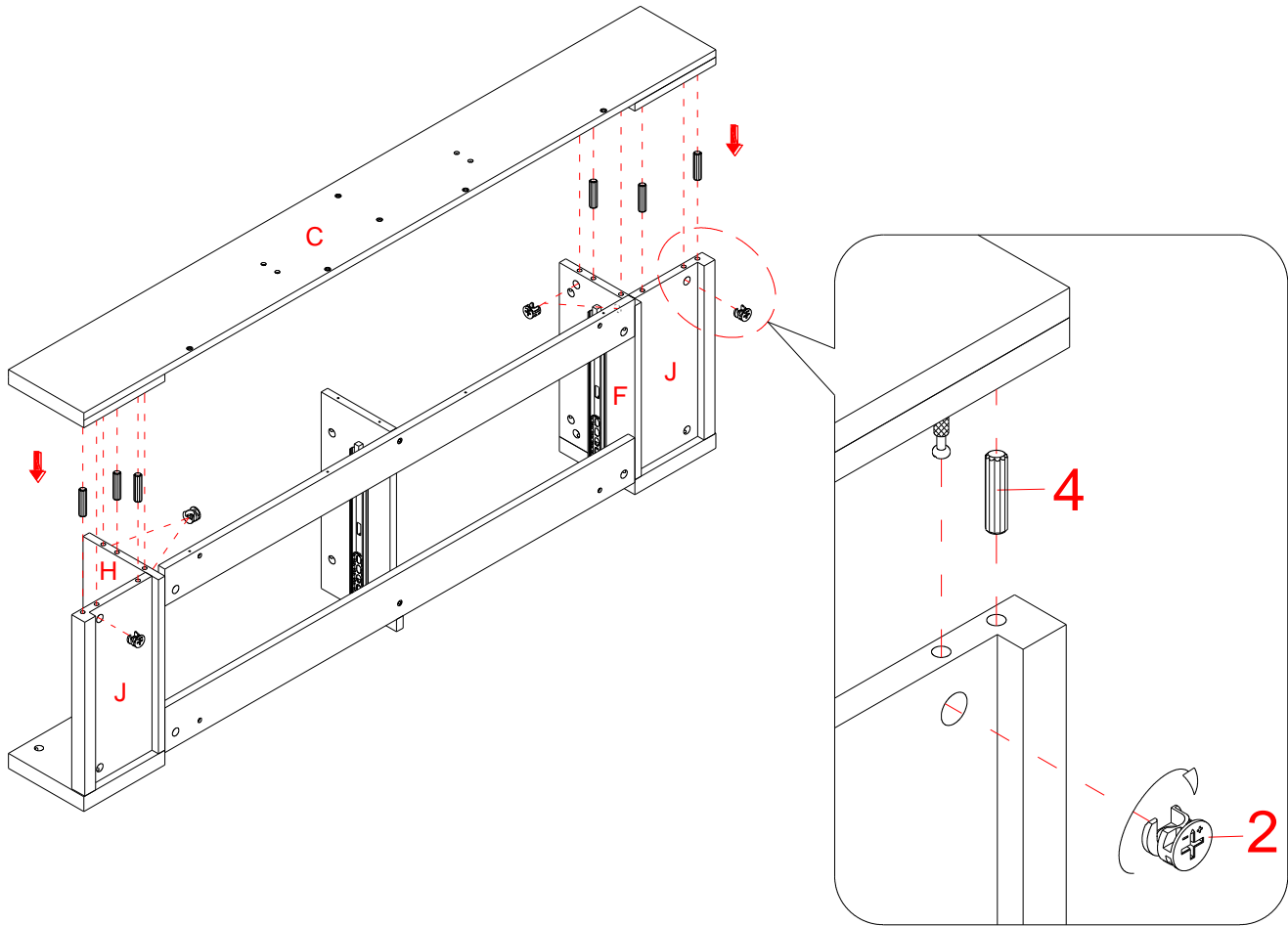

Tuerca de fijación grande
(6 usados en este paso)



②

Clavija de madera de
M8 x 30 mm
(6 usados en este paso)

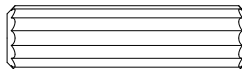

④

16. Adjuntar el panel posterior de la caja cajón (C) a los paneles laterales de la caja cajón (F y H) y a las repisas fijas (J) con 6 tuercas de fijación grandes (2) y 6 clavijas de madera de M8 x 30 mm (4).

Instructivo de ensamble

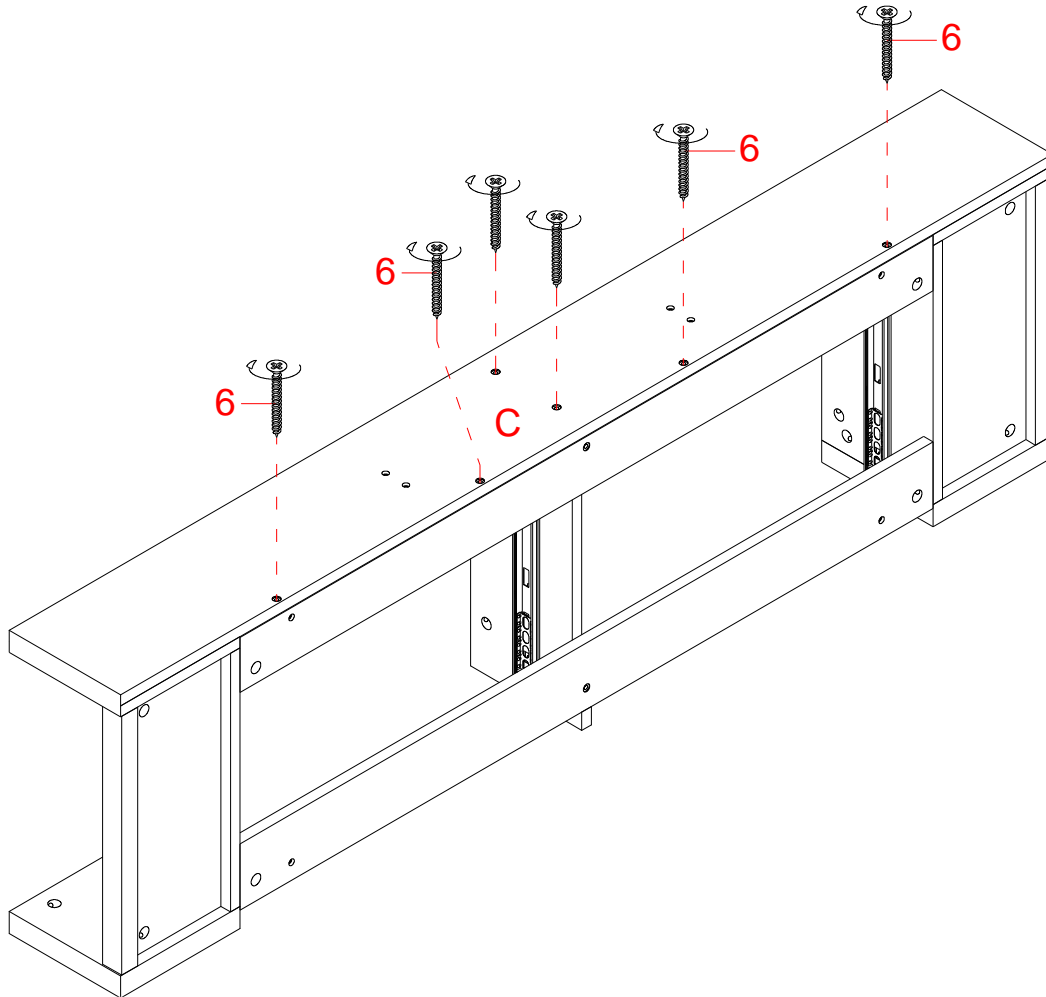

Perno de M4 x 32 mm
(6 usados en este paso)

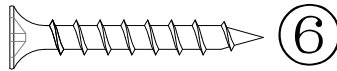

17. Sujetar el panel posterior de la caja cajón (C) al soporte posterior (E) y al panel posterior (K) con 6 pernos de 32 mm (6).

Instructivo de ensamble

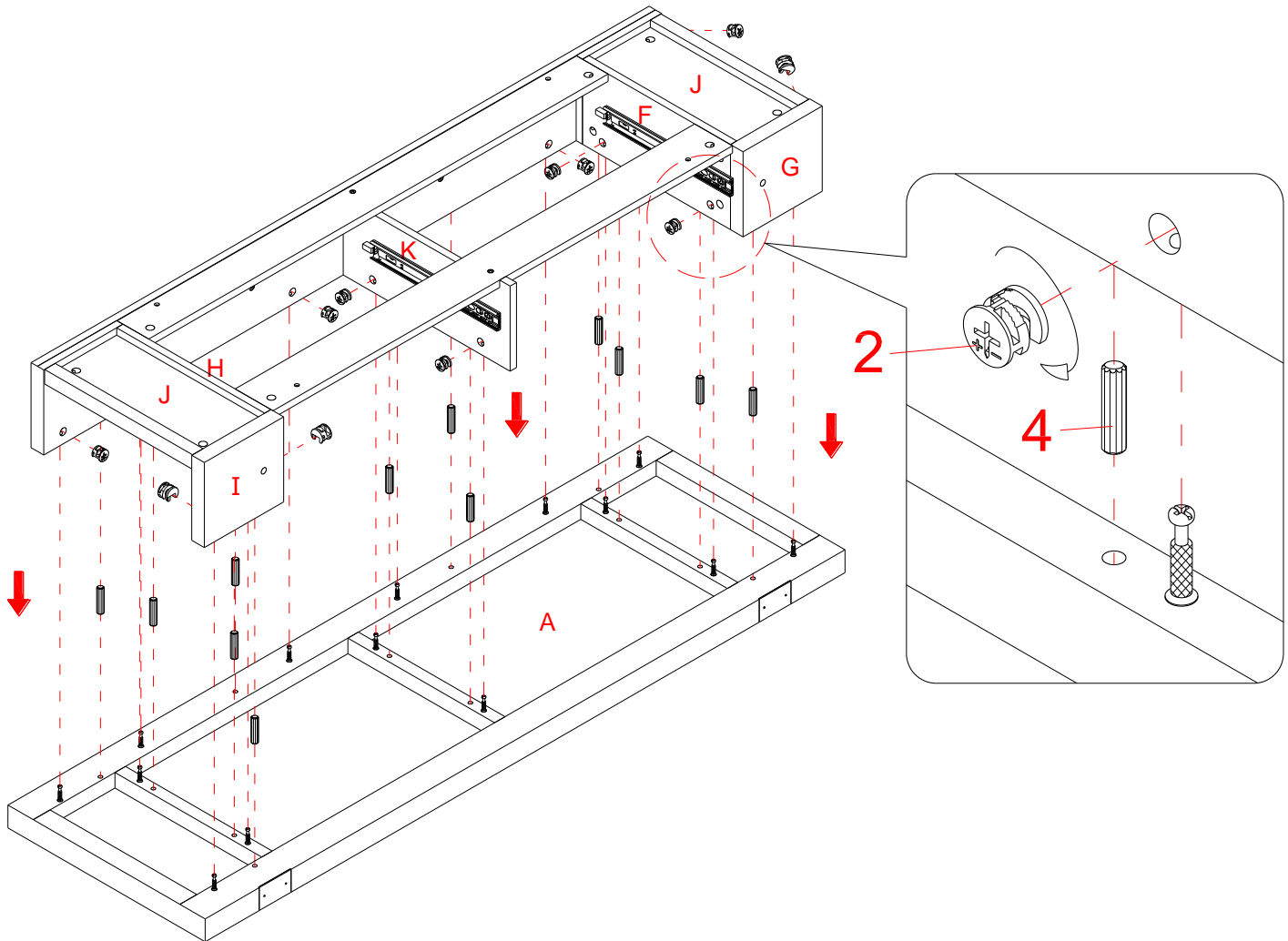

Tuerca de fijación grande
(14 usados en este paso)



②

Clavija de madera de
M8 x 30 mm
(12 usados en este paso)

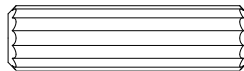

④

18. Posicionar el panel superior (A) boca abajo en una superficie suave y protegida.

19. Alinear y adjuntar el ensamble previo al panel superior (A) con las clavijas de madera de M8 x 30 mm (4) y con las tuercas de fijación grandes (2).

Instructivo de ensamble

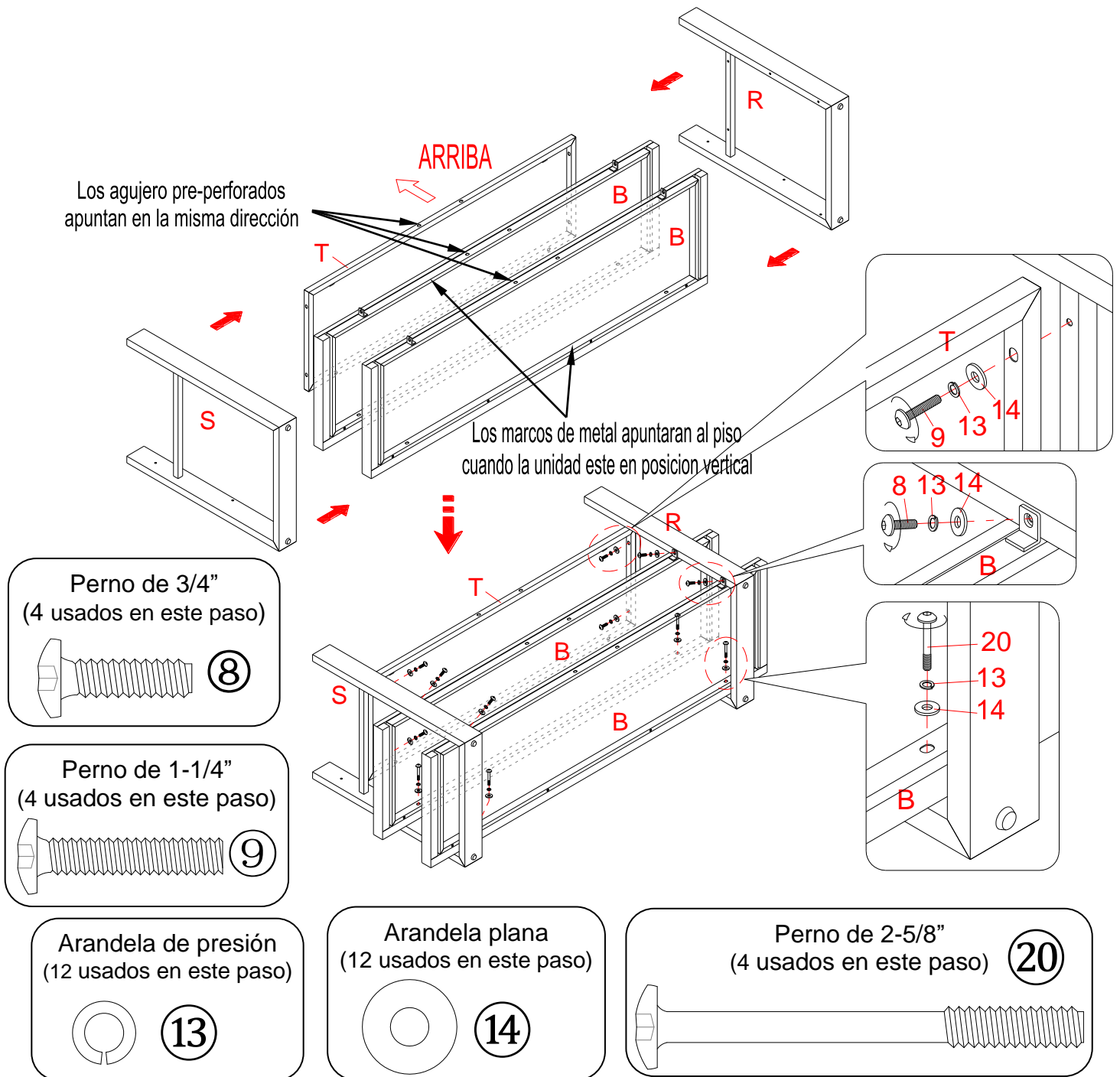

AVISO

NO apriete los pernos hasta que todos los pernos esten listo para el ensamble. Para evitar daños al la rosca, NO sobre apriete los pernos.

20. Meter las 2 repisas inferiores (B) y el marco de metal superior (T) entre las patas (R y S).
21. Adjuntar el marco de metal superior (T) a los rieles superiores de las patas (R y S) con 4 pernos de 1-1/4" (9) y 4 arandelas (13 y 14). Ser seguro que el soporte de metal apuntaran al piso cuando la unidad este en posicion vertical.
22. Sujetar las repisas inferiores (B) entre los postes posteriores de las patas (R y S) con 4 pernos de 3/4" (8) y 4 arandelas (13 y 14) y asegurar los postes frontales con 4 pernos de 2-5/8" (20) y 4 arandelas (13 y 14). **NO apriete los pernos.**

Instructivo de ensamble

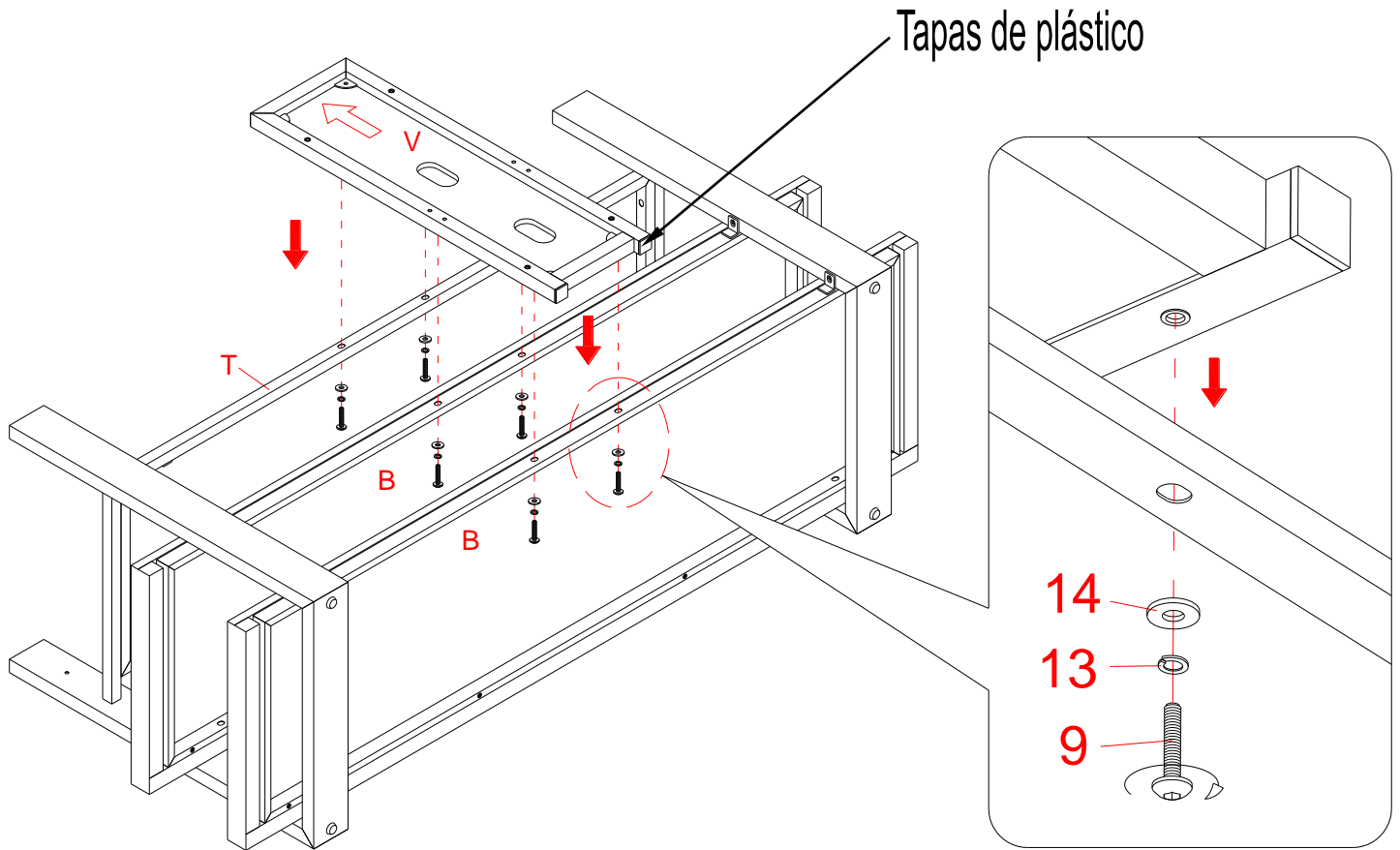

Perno de 1-1/4"
(6 usados en este paso)

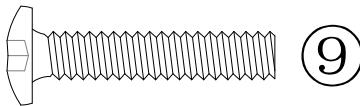

Arandela de presión
(6 usados en este paso)



Arandela plana
(6 usados en este paso)

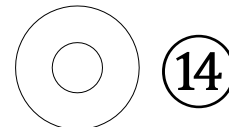

23. Adjuntar el marco posterior (V) a los marcos de metal (B y T) comenzando por la repisa intermedia (B), usando 6 pernos de 1-1/4" (9) y 6 arandelas (13 y 14).

Instructivo de ensamble

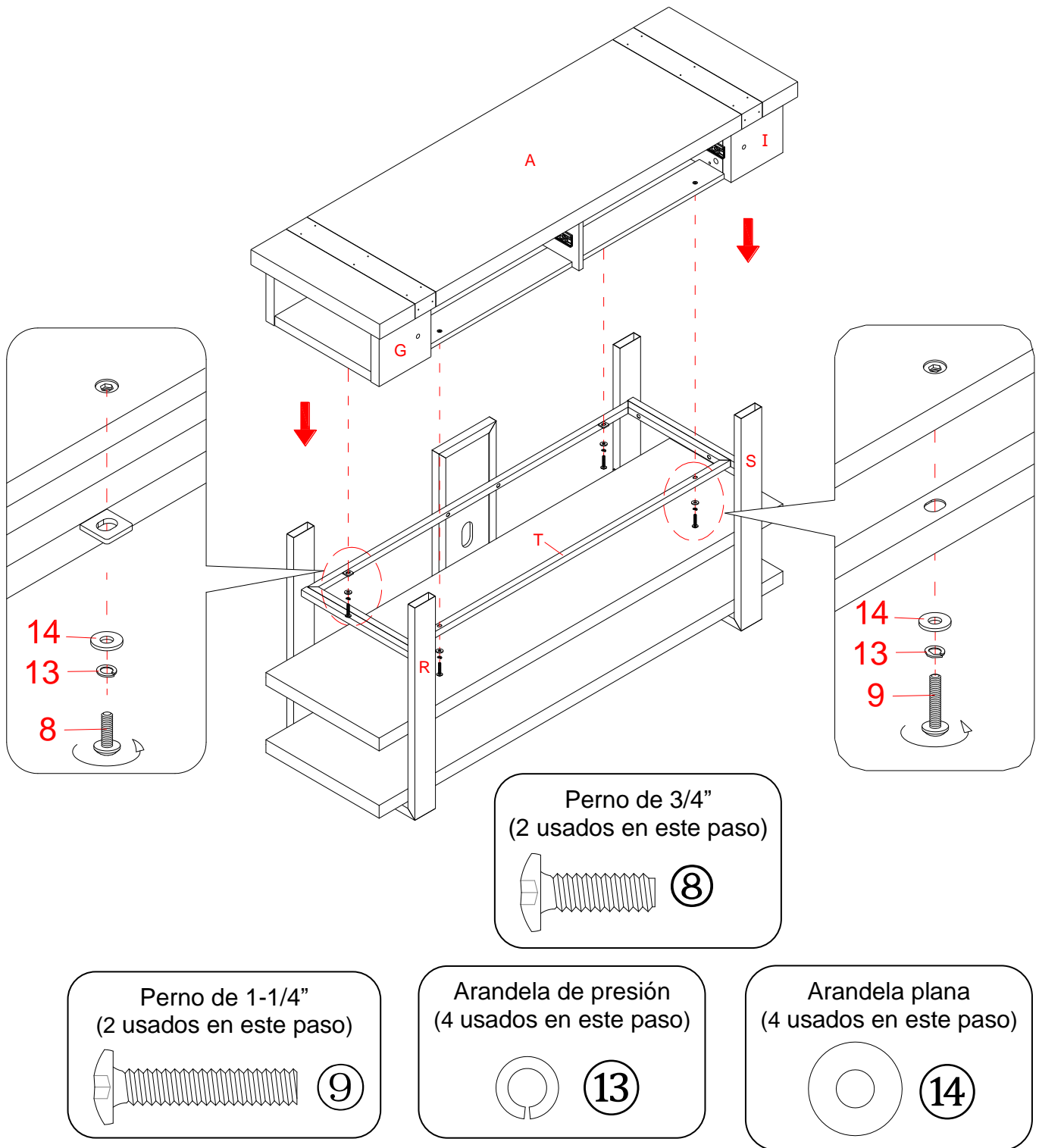

24. Voltar el ensamble previo en posición vertical.

25. Alinear y adjuntar la caja cajón ensamblada al marco de metal superior (T) con 2 pernos de 3/4", 2 pernos de 1-1/4" (9) y 4 arandelas (13 y 14).

Instructivo de ensamble

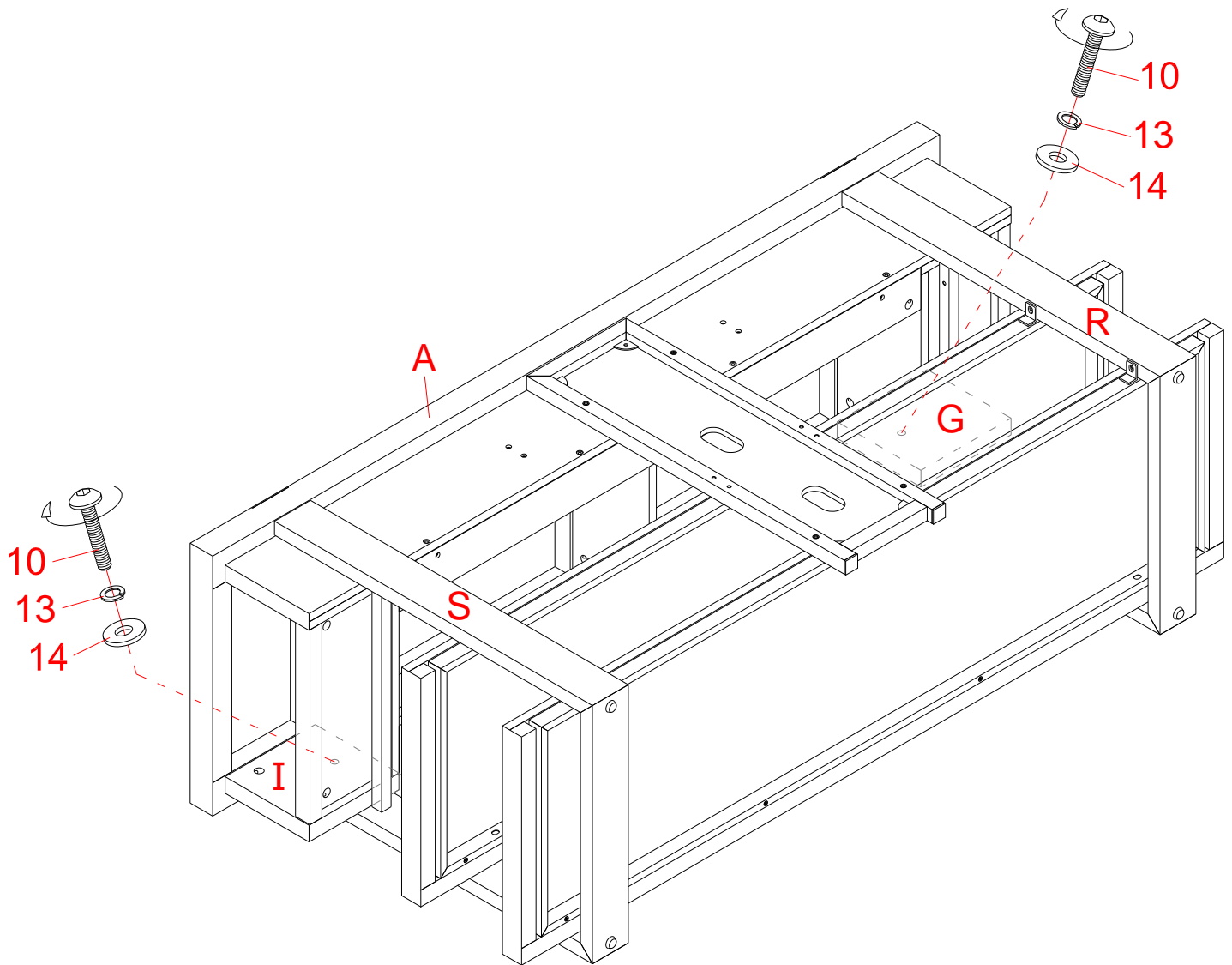

Perno de 1-3/4"
(2 usados en este paso)

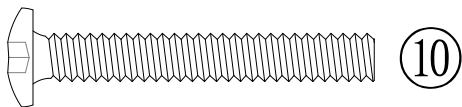

Arandela de presión
(2 usados en este paso)



Arandela plana
(2 usados en este paso)

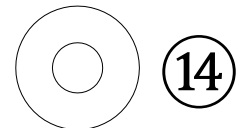

26. Descansar la unidad montada en su parte frontal cuidadosamente. Sujetar los paneles frontales de la caja cajón (G e I) a las patas (R y S) con 2 pernos de 1-3/4" (10) y 2 arandelas (13 y 14). Fije completamente los pernos con la llave hexagonal de 4 mm suministrada.

Instructivo de ensamble

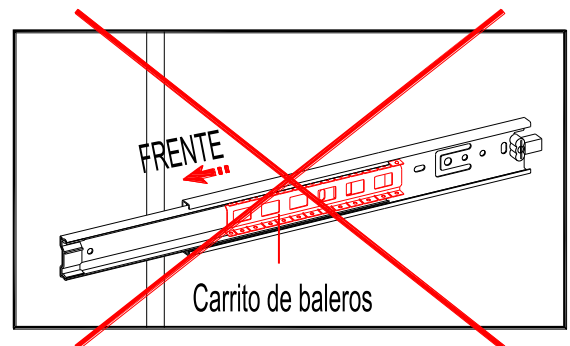
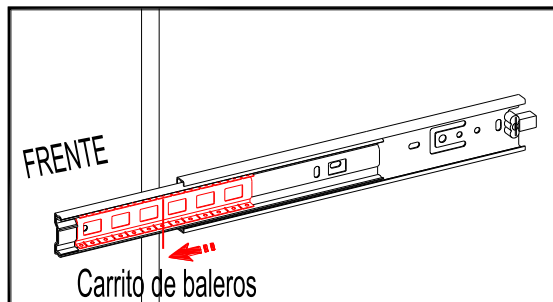
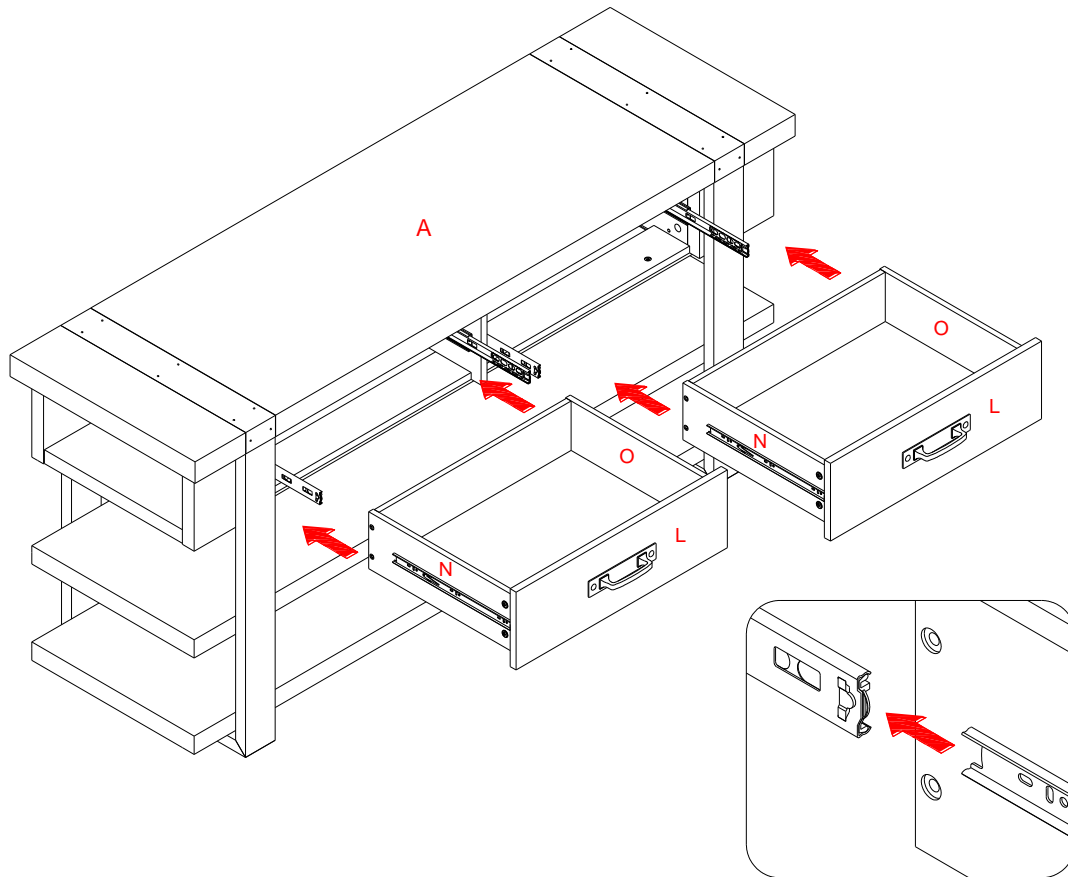

27. Voltear el ensamble previo en posición vertical y insertar los cajones ensamblados en el marco. Extender los carriles de la corredera de baleros en los paneles laterales todo el camino hacia enfrente (incluyendo el carrito de baleros). Luego alinear los complementos de corredera en el cajón ensamblado con los carriles de corredera y empujar el cajón hacia adentro hasta que tope.

NOTA: Si no se mueve suavemente, por favor saque y repita el paso. Si necesita sacar el cajón, por favor jale el cajón todo el camino, y empuje simultáneamente las palancas de liberación de plástico de las correderas de baleros hacia arriba en una y hacia abajo en la otra, después jalé el cajón completamente afuera.

STOP

Si elige la configuración de consola tipo mesa, continúe al siguiente paso.

Si va montar la TV con marco flotante, vaya a la PÁGINA 29.

Instructivo de ensamble para la consola tipo mesa

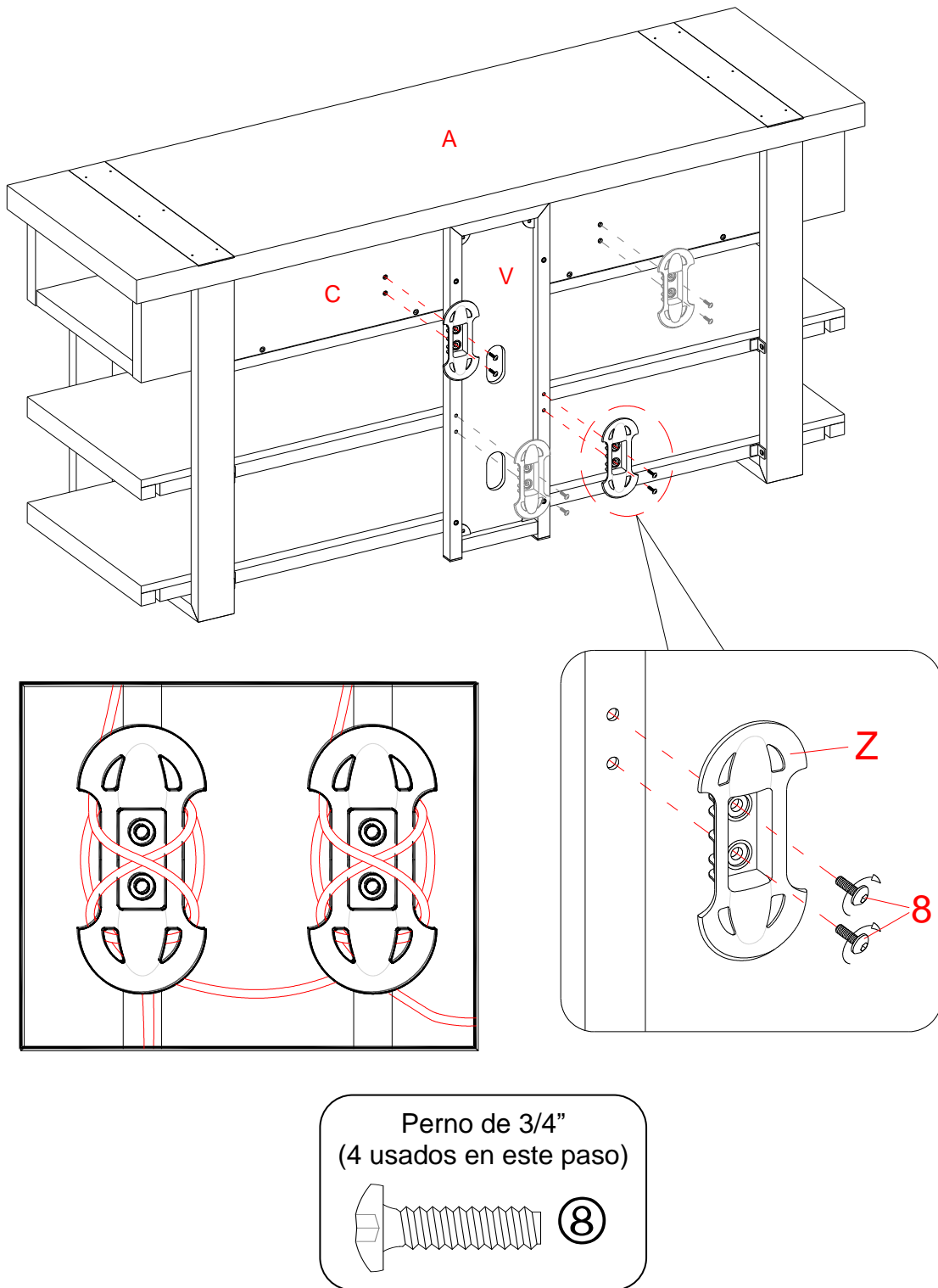

28. Adjuntar 2 guías de cable (Z) a la parte posterior del panel posterior de la caja cajón (C) y al marco posterior (V) con 4 pernos de 3/4" (8). Apretar los pernos con la llave hexagonal.

NOTA: Usted puede usar la guía de cables para mantener su centro de entretenimiento organizado.

Instructivo de ensamble para la consola tipo mesa

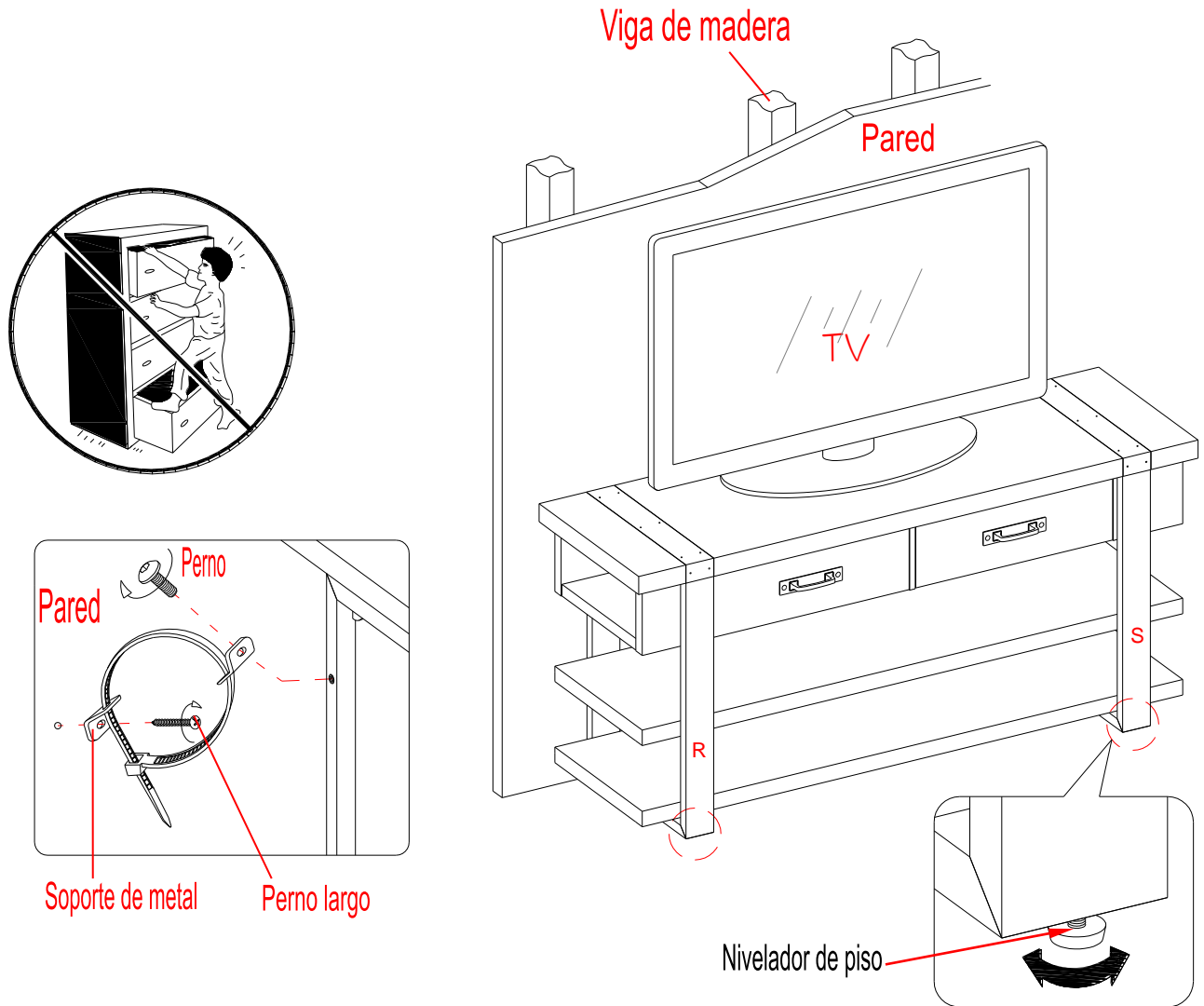

Herramientas necesarias (no incluidas): Desarmador estrella, detector de vigas, taladro eléctrico y taladro de 3mm (0.1").

29. Poner la unidad ensamblada en el lugar deseado contra la pared. Si fuera necesario, ajustar los niveladores de piso pre-adjuntados a la parte inferior de las patas para nivelar la unidad. Ahora, seguir las instrucciones impresas en la bolsa de plástico que contiene el juego de restricción de movimiento para adjuntar los topes de movimiento al marco posterior y a la pared.

NOTA: La ferretería de restricción de movimiento se incluye para la construcción de pared con vigas de madera. Se debe sujetar a un barrote de pared. Dependiendo de la construcción de su pared, es posible que se requiera ferretería diferente. Póngase en contacto con su ferretería local para obtener ayuda. Niños pequeños pueden resultar lastimados por muebles inclinados. Debe instalar el juego de restricción de movimiento con la unidad en función, para prevenir la inclinación de la unidad, causando cualquier accidente o daño. El tope de movimiento es solo una protección, no hay sustituto para la supervisión adulta. El tope de movimiento no es contra terremotos. Si deseara añadir la seguridad adicional contra terremotos, deben ser comprados e instalados por separado.

30. La consola está lista para usarse. Asegurarse de posicionar la TV de pantalla plana en el centro de la consola.

NOTA: Si desea montar en la pared, vaya a la PÁGINA 37.

Instructivo de ensamble para: Marco flotador

Los enchufes roscados para las guías de cable apuntan hacia atrás

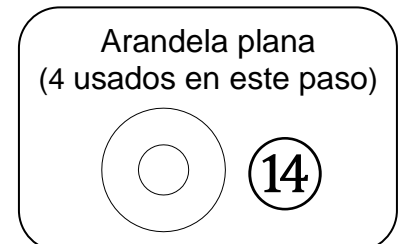
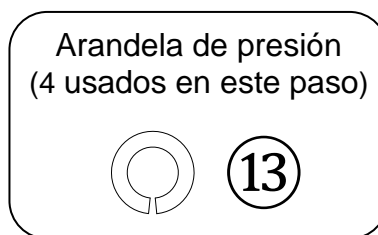
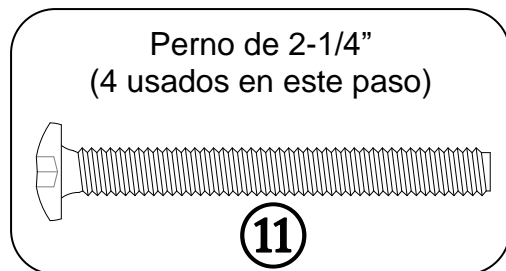
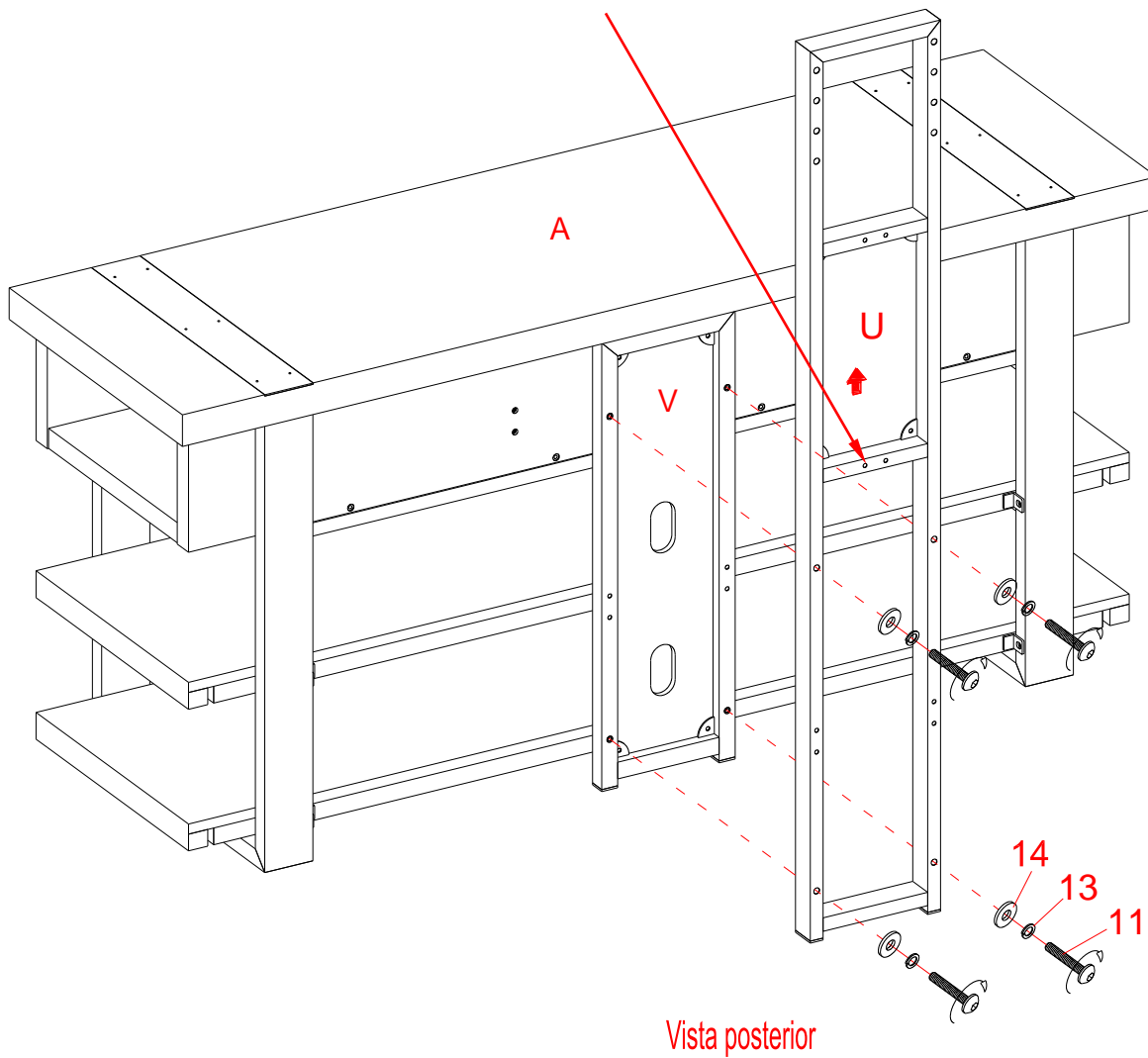

31. Adjuntar el poste largo (U) a la parte posterior del marco posterior (V) con 4 pernos de 2-1/4" (11) y 4 arandelas (13 y 14). Fije completamente los pernos con la llave hexagonal de 4 mm suministrada.

Instructivo de ensamble para la montura del marco flotante

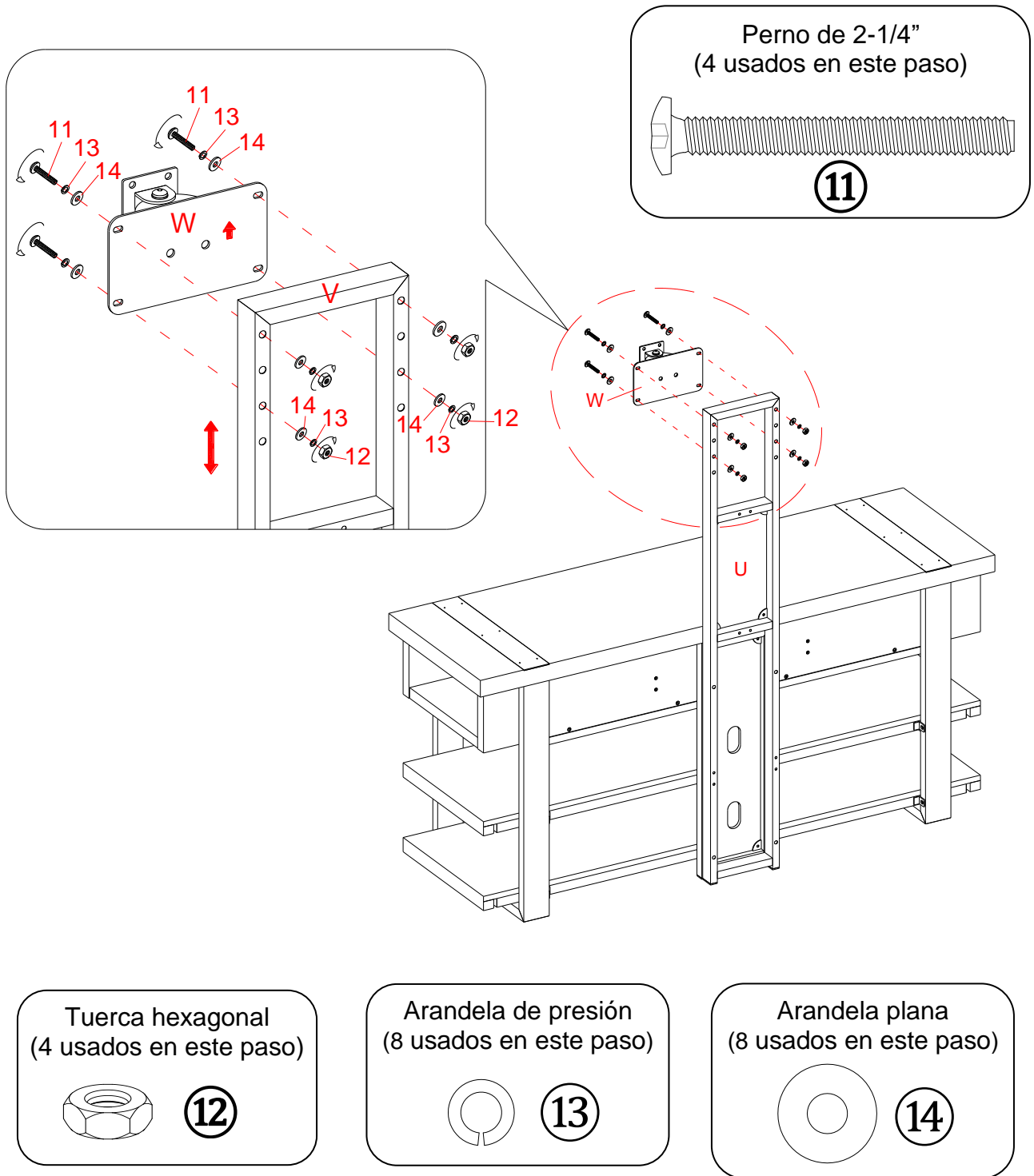

32. Adjuntar el soporte del pivote (W) a la parte superior del poste largo (U) con la cabeza del perno del pivote arriba, como se muestra arriba. Apretar con las llaves española y hexagonal de 4 mm.

NOTA: El poste puede proveer 2 opciones de altura para el juego de TV. Consultar el tamaño de su TV y ajustar el soporte del pivote a su altura deseada para mejor visión.

Instructivo de ensamble para la montura del marco flotante

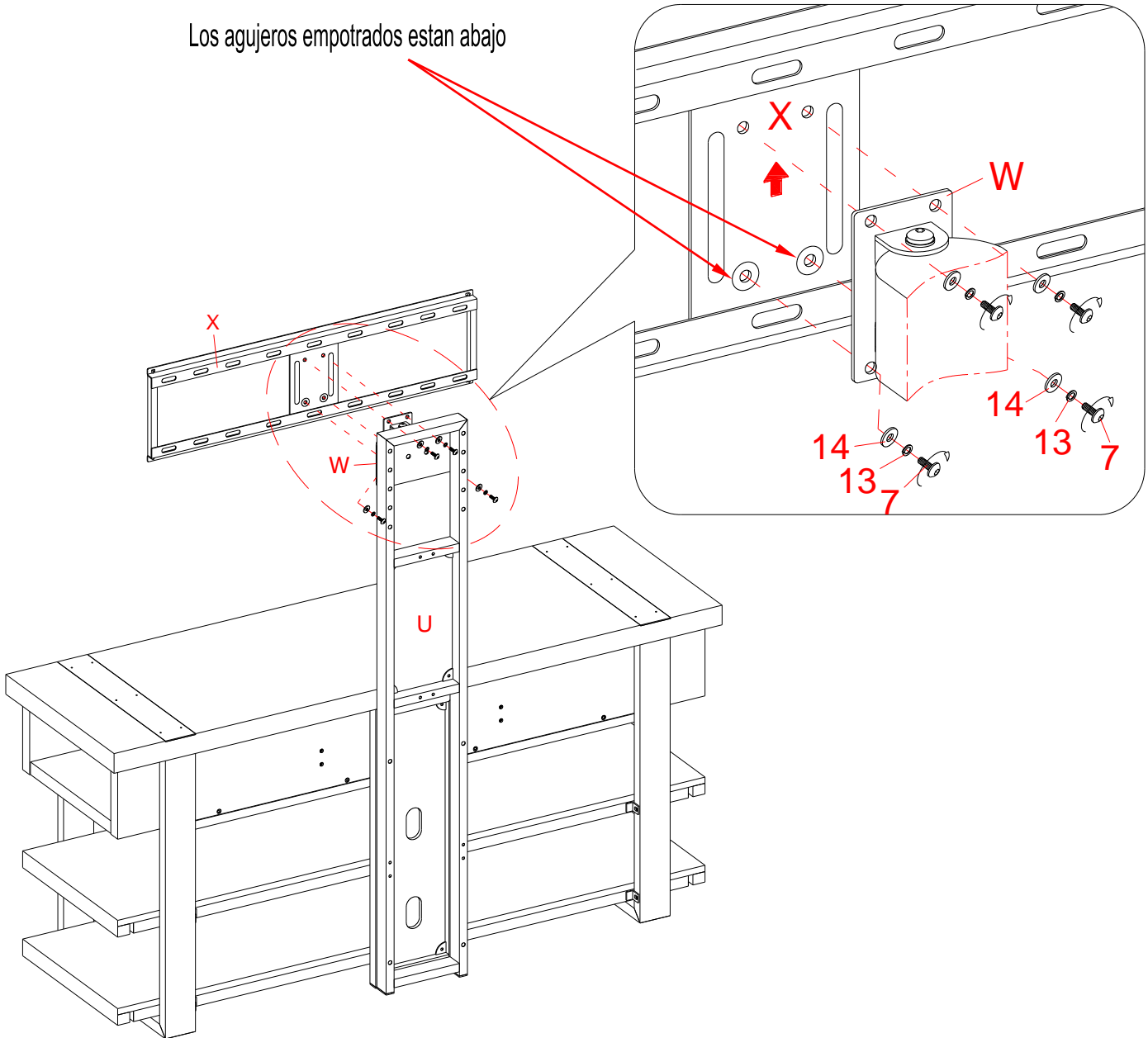

Perno de 1/2"
(4 usados en este paso)

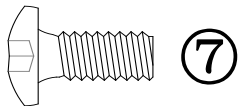

Arandela de presión
(4 usados en este paso)

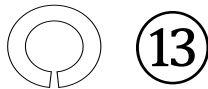

Arandela plana
(4 usados en este paso)

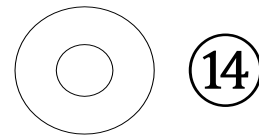

33. Mantener y adjuntar el lado plano del marco de montaje (X) al soporte del pivote (W) usando 4 pernos de 1/2" (7) y 4 arandelas (13 y 14). Asegurar de que los agujeros empotrados en el marco de montaje estén abajo. Fije completamente los pernos con la llave hexagonal de 4 mm suministrada.

Para montar el marco en televisiones con respaldo plano

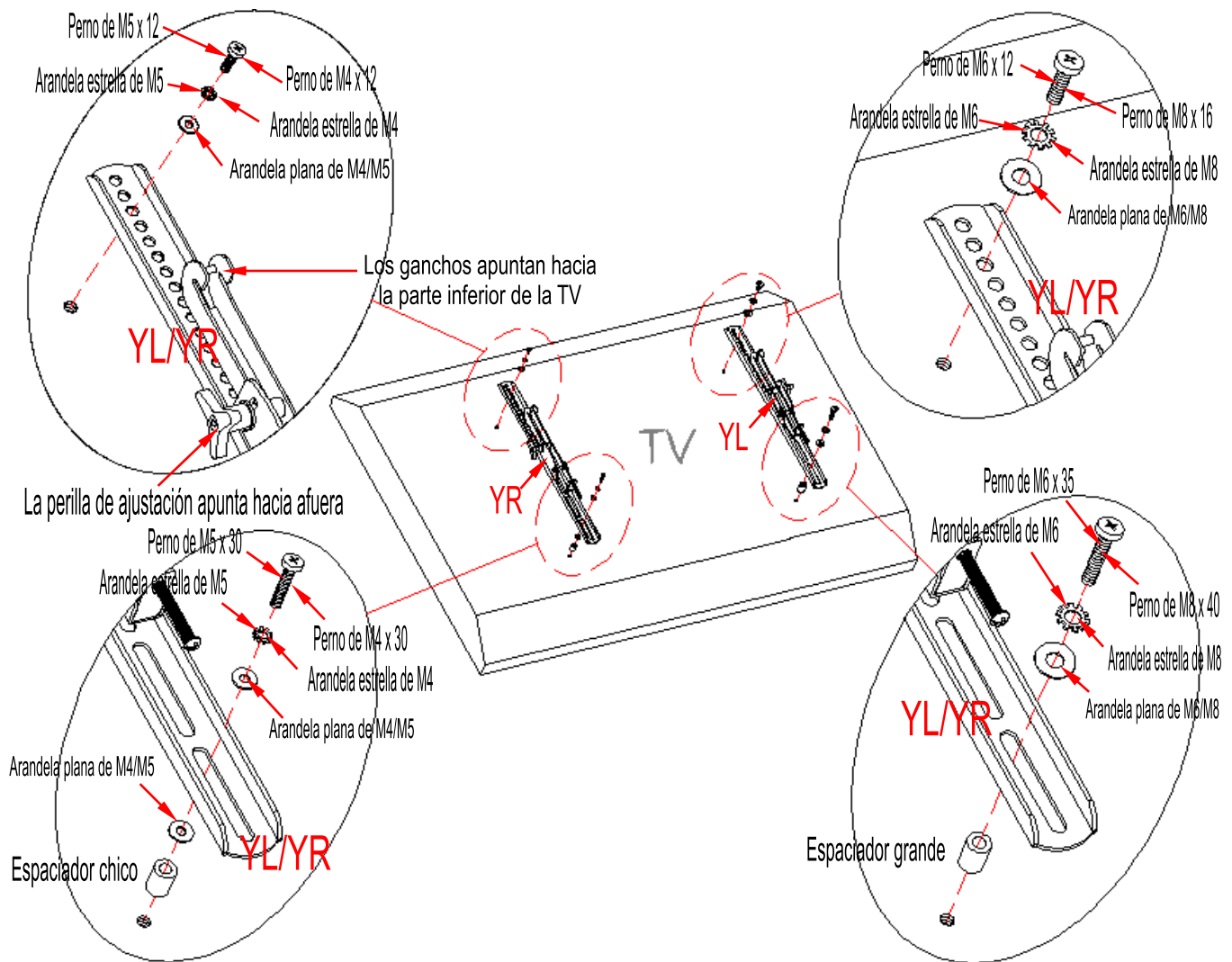

NOTA: Para televisiones con respaldos curvos o desnivel proceda directamente a la siguiente página.

34. Determine el diámetro correcto de pernos que utilizará en su televisión atornillando con sus manos para asegurar que entren bien, si encuentra resistencia deténganse inmediatamente. Si no encuentra el perno adecuado consulte a su tienda de ferretería local.
35. Siga el diagrama apropiado para adjuntar los soportes de monitor (YL/YR) al respaldo de su TV con los sujetadores seleccionados. Asegurar de que los soportes del monitor estén centrados y nivelados con cada uno. Asegurar los pernos con el desarmador estrella. No sobre-apriete los pernos.

NOTA: Recargue la TV contra la pared u otra parte sólida cuando asegure los soportes del monitor. POR NINGUNA RAZÓN coloque la televisión boca abajo en el vidrio, esto puede producir un daño permanente.

NOTA: Si monta su TV en la configuración en la pared, una vez que haya terminado la instalación del soporte del monitor, vaya a la PÁGINA 37.

Para montar el marco en televisiones con respaldo curvo/desnivel

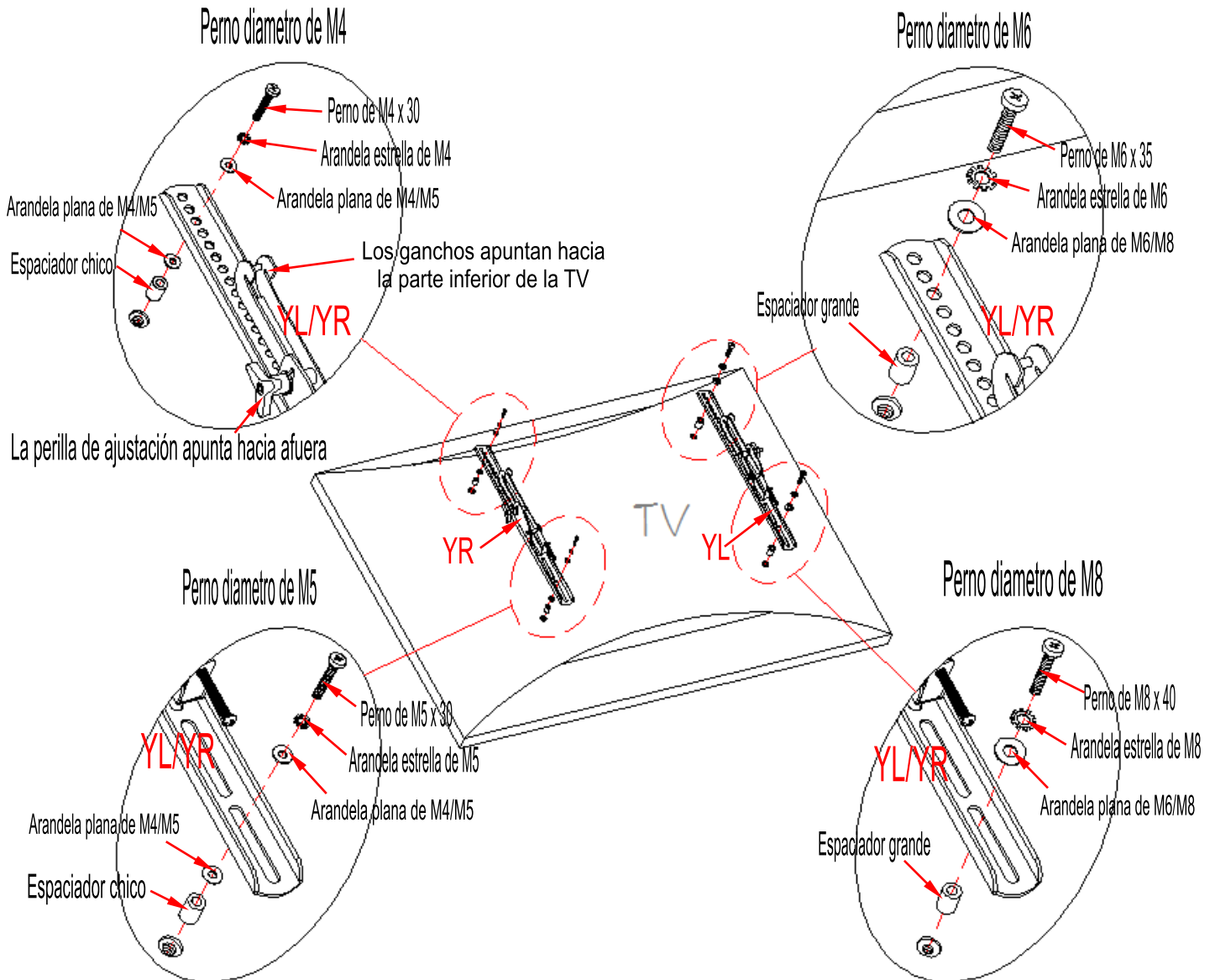

36. Determine el diámetro correcto de pernos que utilizará en su televisión atornillando con sus manos para asegurar que entren bien, si encuentra resistencia deténganse inmediatamente. Si no encuentra el perno adecuado consulte a su tienda de ferretería local.

37. Siga el diagrama apropiado para adjuntar los soportes de monitor (YL/YR) al respaldo de su TV con los sujetadores seleccionados. Asegurar de que los soportes del monitor estén centrados y nivelados con cada uno. Asegurar los pernos con el desarmador estrella. No sobre-apriete los pernos.

NOTA: Recargue la TV contra la pared u otra parte sólida cuando asegure los soportes del monitor. **POR NINGUNA RAZÓN** coloque la televisión boca abajo en el vidrio, esto puede producir un daño permanente.

NOTA: Si monta su TV en la configuración en la pared, una vez que haya terminado la instalación del soporte del monitor, vaya a la PÁGINA 37.

Instructivo de ensamble para la montura del marco flotante

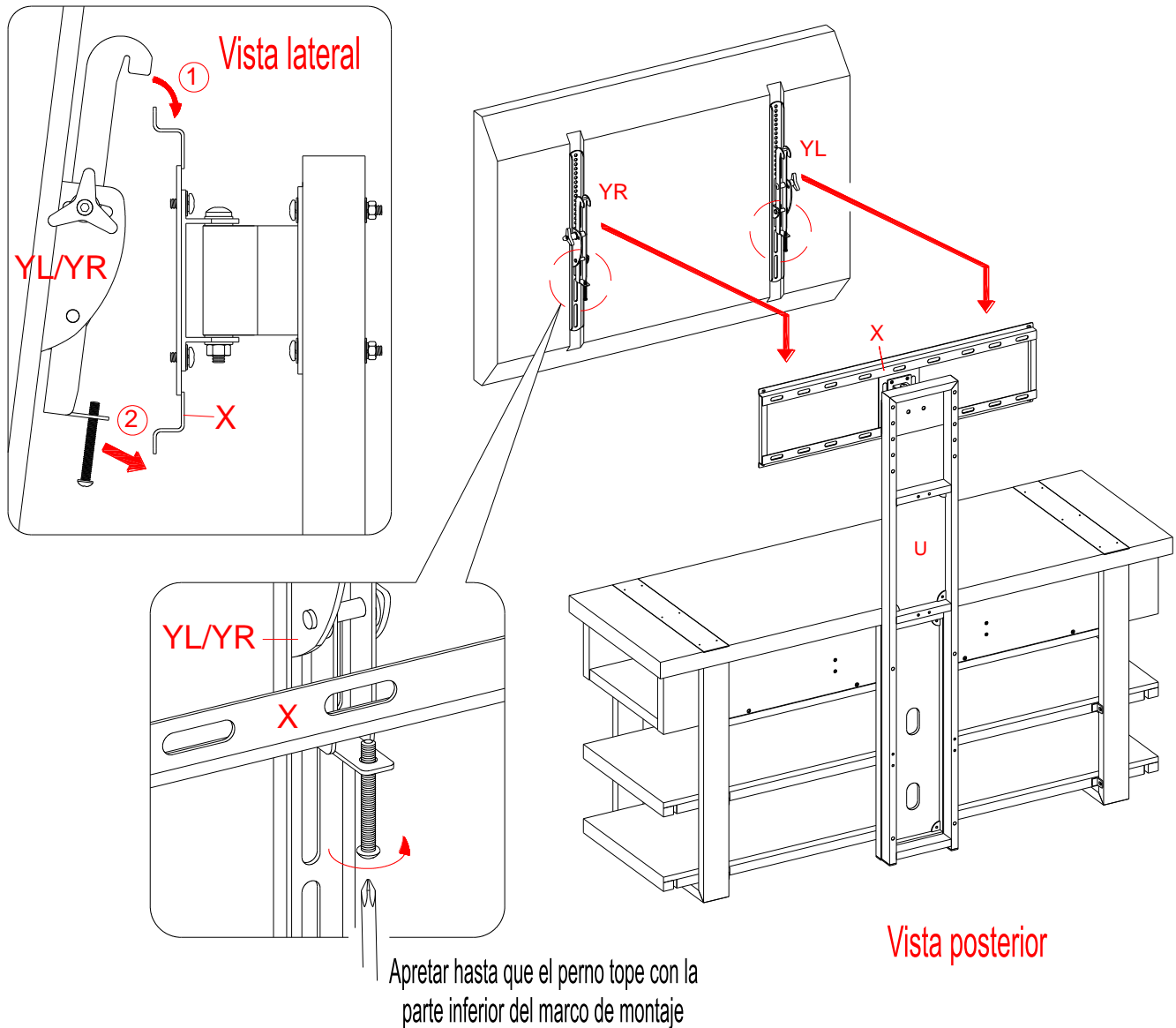

ASEGURAR QUE LOS PERNOS ESTEN APRETADOS Y QUE EL POSTE ESTEN EN UN ANGULO DE 90 GRADOS. USANDO UN NIVEL DE CALIDAD PARA VERIFICAR QUE EL MARCO DE MONTAJE ESTÉ NIVELADO ANTES DE LA INSTALACIÓN DE LA TV.

38. Pedir asistencia para levantar la TV para adjuntar los soportes de monitor (YL/YR) en el marco de montaje (X). Poner los ganchos de los soportes de monitor (YL/YR) sobre el marco de montaje (X) y engánchelos hacia las barras del marco.

NOTA: Aflojar el perno de bloqueo que está pre-adjuntado a los soportes para asegurar un ajuste fácil en los ganchos inferiores.

39. Centrar la TV y apretar ambos pernos de bloqueo con el desarmador estrella largo hasta que topen con la parte inferior del marco de montaje (X) para asegurar de que su TV esté segura y asegurada.

Instructivo de ensamble para la montura del marco flotante

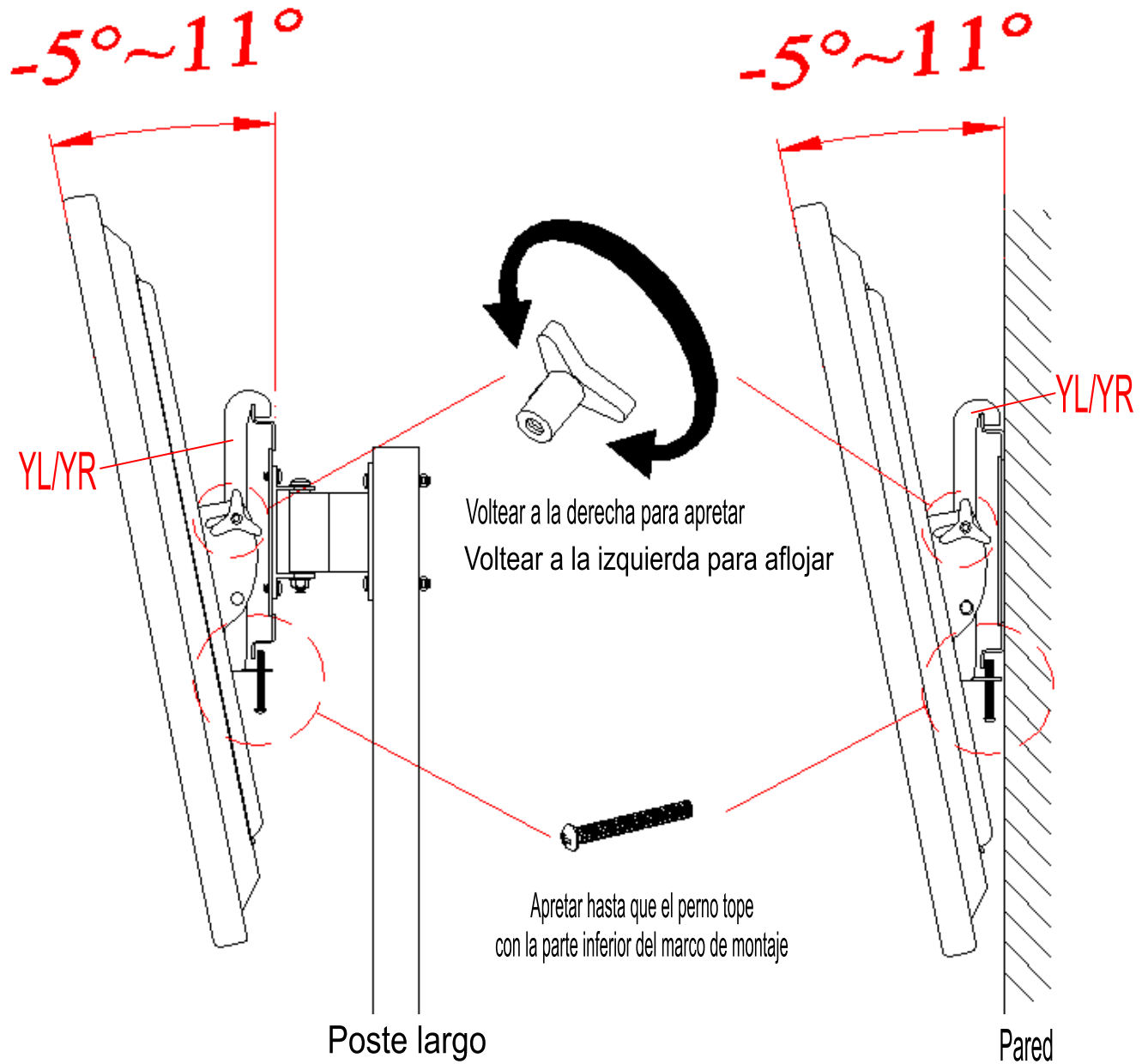

40. Los soportes de monitor (YL/YR) pueden inclinarse hasta 11° para abajo y 5° para arriba, dependiendo de su posición de mayor visión. Mantener la llave hexagonal de $3/16''$ para asegurar de que las perillas de ajuste estén apretadas.

Instructivo de ensamble para la montura del marco flotante

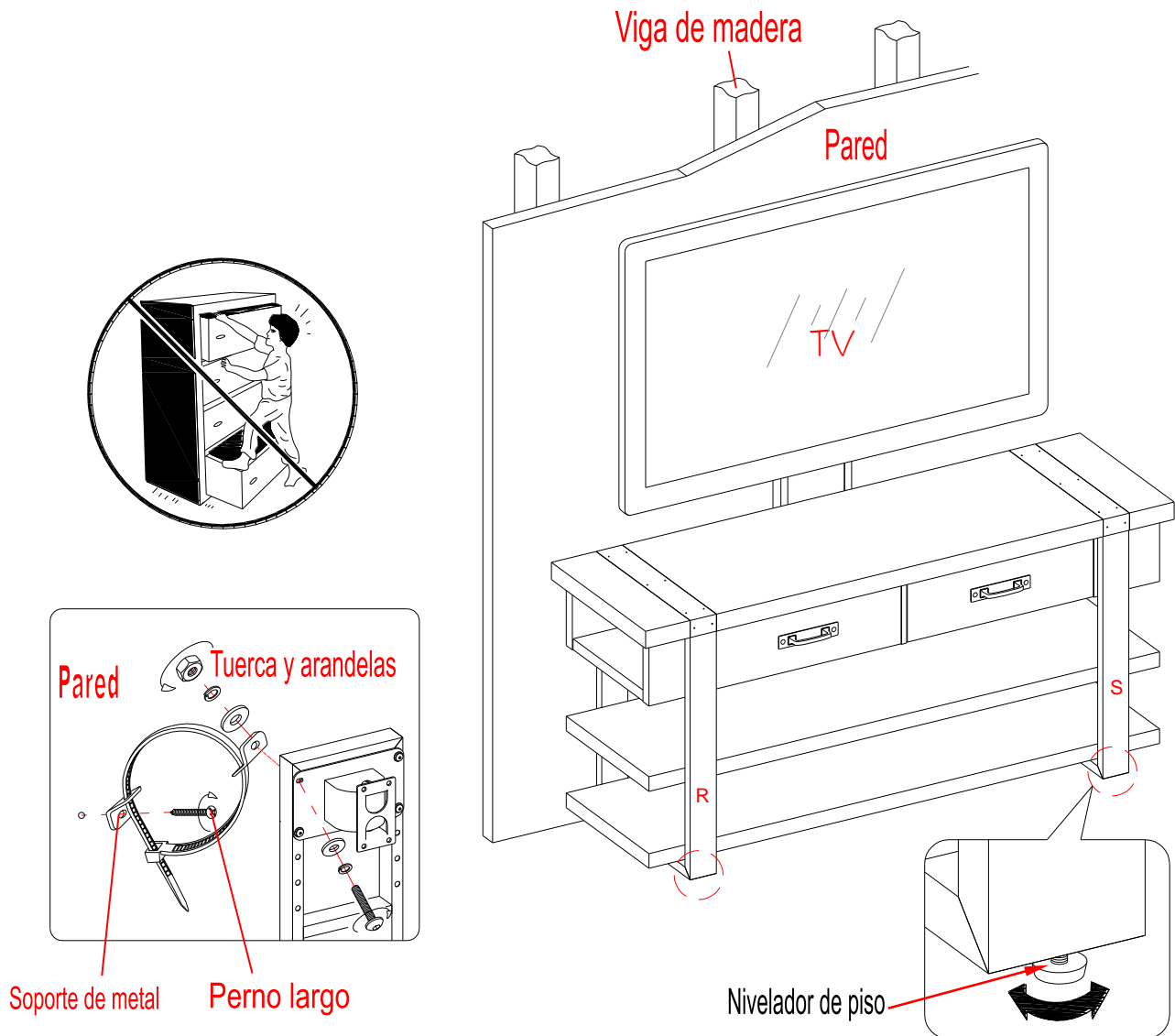

41. Adjuntar 2 guías de cable (Z) a la parte posterior del poste largo (U) con 4 pernos de 3/4" (8).

42. Poner la unidad ensamblada en el lugar deseado contra la pared. Si fuera necesario, ajustar los niveladores de piso pre-adjuntados a la parte inferior las patas (R y S) para nivelar la unidad. Ahora, seguir las instrucciones impresas en la bolsa de plástico que contiene el juego de restricción de movimiento para adjuntar los topes de movimiento al marco posterior y a la pared.

NOTA: La ferretería de restricción de movimiento se incluye para la construcción de pared con vigas de madera. Se debe sujetar a un barrote de pared. Dependiendo de la construcción de su pared, es posible que se requiera ferretería diferente. Póngase en contacto con su ferretería local para obtener ayuda. Niños pequeños pueden resultar lastimados por muebles inclinados. Debe instalar el juego de restricción de movimiento con la unidad en función, para prevenir la inclinación de la unidad, causando cualquier accidente o daño. El tope de movimiento es solo una protección, no hay sustituto para la supervisión adulta. El tope de movimiento no es contra terremotos. Si deseara añadir la seguridad adicional contra terremotos, deben ser comprados e instalados por separado.

43. La consola está lista para uso. Mueva la TV a la izquierda o derecha para mejor control de visión.



Los siguientes pasos son solo para ellos que desean montar su TV en la pared. Si ya monto su TV en el pivote flotante o planea mostrar su TV en la superficie superior de la consola, olvide los siguientes pasos.

Instructivo de ensamble para el montaje de pared universal Instalando el marco de montaje en una PARED DE MADERA

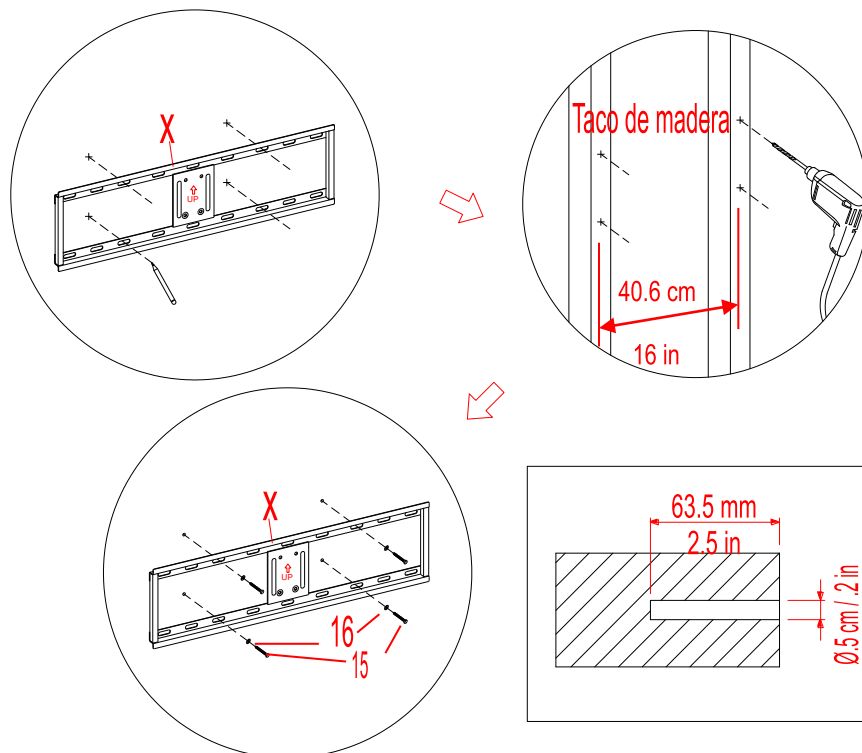

NOTA: Si está montando su TV en ladrillos, concreto solido o bloques de concreto omita está sección. Está ensamble requiere un taladro, nivelador y buscador de estudios (no incluido).

44. Usando un buscador de estudios, encontrar los bordes de los tacos de madera. Encontrar la línea central de cada taco y dibujar una línea vertical de referencia en la pared sobre cada uno. Poner el nivelador del marco de montaje (X) contra la pared donde desea montar la TV. Usando el marco de montaje (X) como templado, marcar los 4 puntos de perforación (2 arriba, 2 abajo) con un lápiz en las líneas verticales de referencia que dibujo.
45. Con un taladro (no incluido) perforar agujeros de 3/16 pulgadas de diámetro al menos 2 ½ pulgadas de profundo en los 4 puntos. Mientras mantiene la placa soporte en su lugar, flojamente atornillar los pernos especiales (15).
46. Asegurar el marco de montaje (X) a la pared con los pernos especiales (15) y las arandelas (16) en los puntos de perforación. Apretar los pernos, pero tenga cuidado de no sobre-apretar.

AVISO NO sobre-apriete los pernos especiales. Apretar los pernos solo cuando la arandela del perno especial esté jalado firmemente contra la placa de pared. Si hay una capa de tablaroca u otro material, está tablaroca no puede exceder 5/8 pulgadas de profundidad. La falla de escuchar está precaución puede resultar en daño a la propiedad y/o daños personales.

Instructivo de ensamble para instalar el marco de montaje a PAREDES DE LADRILLO, CONCRETO SOLIDO O BLOQUES DE CONCRETO

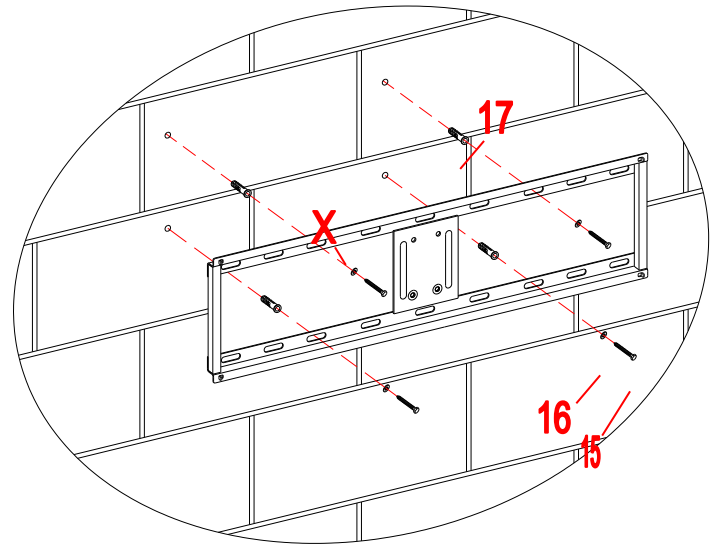
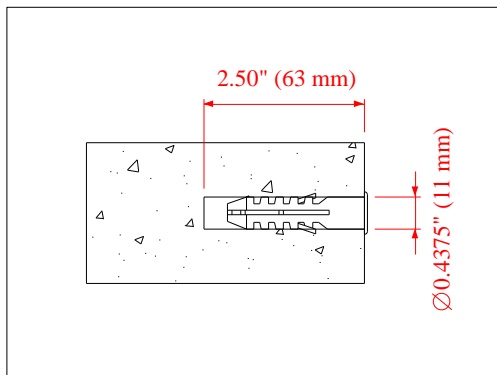
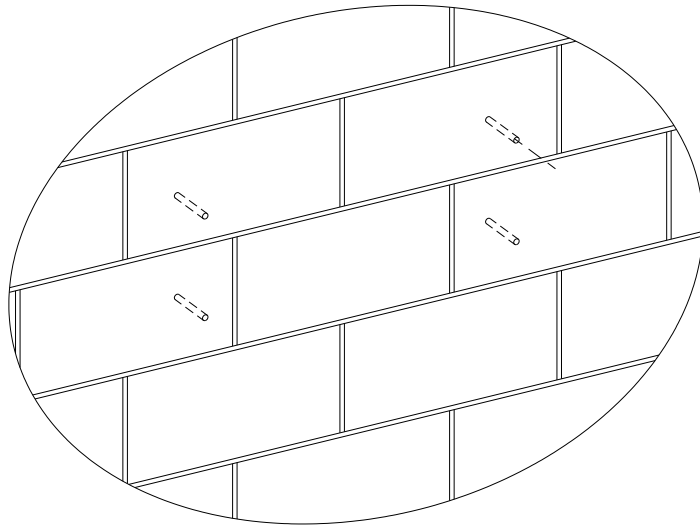

⚠ AVISO Peso máximo 135 lb. (61.3 kg)

⚠ AVISO Las anclas de concreto deberían ser usadas solamente para montar en masonería. NUNCA usar las anclas para montar la unidad en tablaroca.

NOTA: Si está montando su TV en una pared con tacos de madera omita esta sección. Este ensamble requiere un taladro y nivelador (no incluido).

47. Empiece por poner el nivelador del marco de montaje (X) contra la pared donde desea montar la TV. Usando el marco de montaje (X) como templatado, marcar los 4 puntos de perforación con un lápiz.
48. Con un taladro (no incluido) en baja potencia, perforar agujeros de 7/16 pulgadas de diámetro de al menos 2 ½ pulgadas (63 mm) de profundo. Insertar las anclas para concreto (17) en los agujeros pre-perforados para que estén a nivel con la pared.
49. Poner el nivelador del marco de montaje (X) contra la pared donde desea montar la TV. Asegurar el marco de montaje (X) a la pared con los pernos especiales (15) y las arandelas (16) en los puntos de perforación. Apretar los pernos, pero tenga cuidado de no sobre-apretar.

Instructivo de ensamble

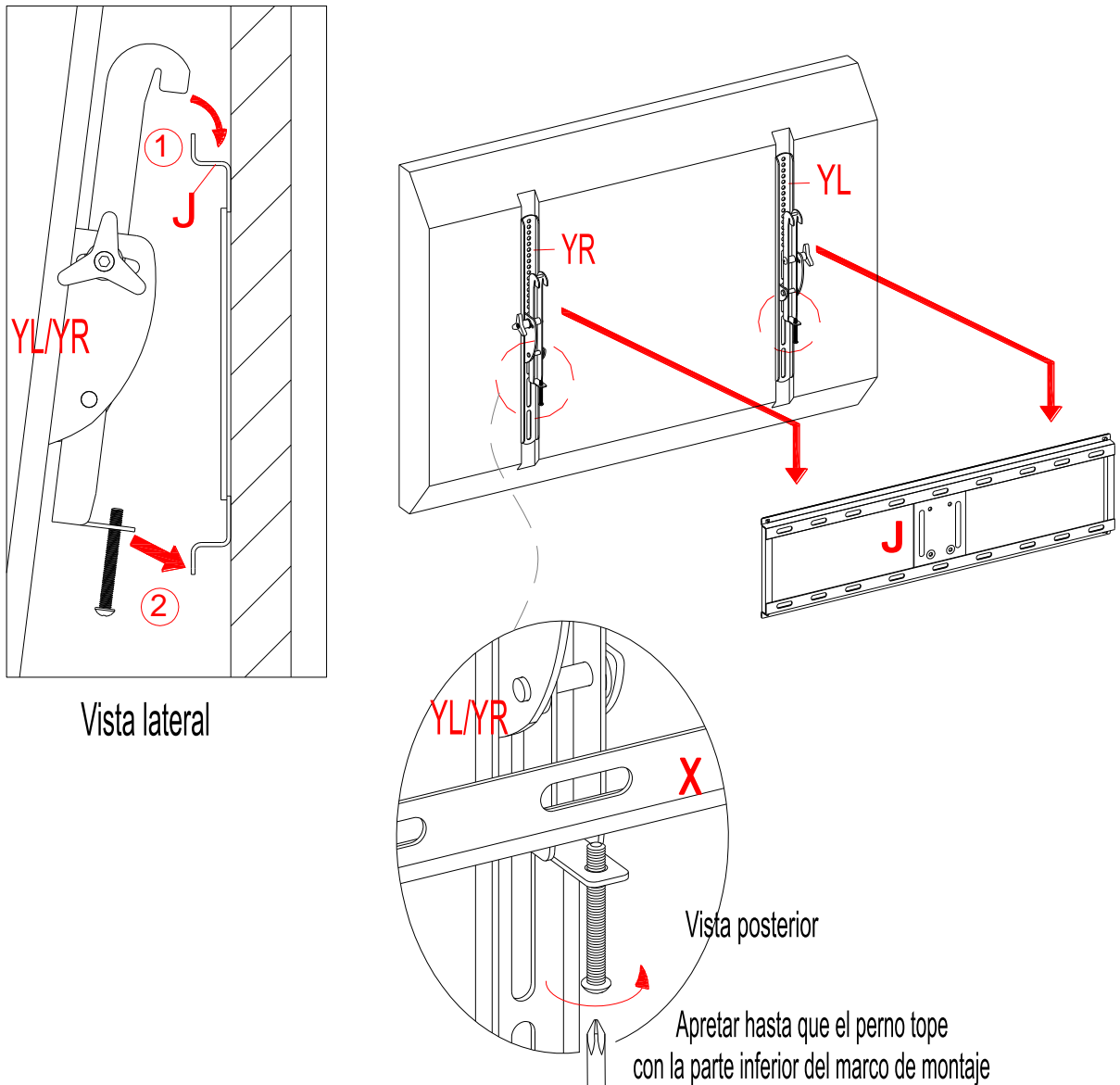

50. Adjuntar los soportes de monitor (YL/YR) a la espalda de la TV siguiendo los pasos 34 y 35, o 36 y 37, dependiendo del tipo de TV que tenga.
51. Pedir asistencia para levantar la TV para adjuntar los soportes de monitor en el marco de montaje (X). Poner los garfios de los soportes sobre el marco y enganchar en las barras del marco. Proceder a centrar la TV.
52. Una vez que la TV esté en posición, apretar ambos pernos de bloqueo con el desarmador estrella largo hasta que topen en la parte inferior del marco de montaje para asegurar de que su TV esté segura y asegurada.
53. Poner la consola ensamblada abajo de su TV. Finalmente, conectar los cables A/V y de poder a su TV. Ya está listo para disfrutar su TV de pantalla plana montada en su pared.

Mantenimiento y Cuidados

- Use una toalla suave y limpia para evitar daños y rayaduras.
- Uso de cera para pulir muebles no es necesario. Si desea usar cera, pruébela en un área que no sea visible para revisar su funcionamiento.
- Usar solventes de cualquier tipo puede dañar el acabado del mueble.
- Nunca use agua para limpiar la unidad, ya que le puede dañar el acabado.
- Siempre utilice protección para vasos cuando los ponga sobre la unidad.
- Líquidos derramados deben limpiarse inmediatamente, con una toalla suave evitando tallar.
- Siempre utilizar protectores en caso de poner cosas calientes. El calor puede provocar una reacción química en el acabado y dañarlo.
- En caso que su unidad sea manchada durante el uso le recomendamos hablar a un profesional para que le ayude.
- Revisar los pernos periódicamente y apretar en caso necesario.

Más recomendaciones para el cuidado de su Mueble

Es mejor mantener la unidad en un área de clima controlado. Temperatura extrema y cambios de humedad pueden causar cambios como partes pandas, molduras que se contraigan o que la madera se raje. Es recomendable mantener la unidad lejos del sol directo ya que puede dañar el acabado.

Cuidados adecuados y limpieza pueden extender la vida útil de su unidad. Siga estas recomendaciones y mantendrá su mueble en buenas condiciones de uso por muchos años.

Un plumón es proveído en caso de pequeñas raspaduras o golpes que sucedan durante el ensamble o envío.

Esperamos que disfrute su mueble por muchos años.
¡Gracias por su compra!

GARANTÍA DE CALIDAD

Nosotros estamos seguros que usted se encontrará feliz con la compra de esté producto de Whalen Furniture.

Si esté producto tiene algún defecto de ensamble o material, o si tiene alguna falla en uso normal, nosotros lo repararemos o lo re-emplazaremos hasta por un año a partir de la fecha de compra. Todo producto de Whalen Furniture es diseñado para alcanzar sus expectativas más altas. Nosotros le garantizamos que inmediatamente podrá ver el valor de nuestra mercancía de la más alta calidad.

Está garantía le proporciona derechos legales específicos y talvez tenga otros derechos que varían de estado a estado.

Customer Service: 866-942-5362
8:30 a.m. - 4:30 p.m., PST, Monday to Friday
www.whalenstyle.com