

# Kitchen Cart

Stock # PWS336158813031



## **ADULT ASSEMBLY REQUIRED**

If you have any questions regarding assembly or if parts are missing, DO NOT return this item to the store where it was purchased. Please call our customer service number and have your instructions and parts list ready to provide the model name, part name or factory number:

**1-866-942-5362**

Pacific Standard Time: 8:30 a.m. - 4:30 p.m., Monday - Friday

Or visit our web site 24 hours a day, 7 days a week for product assistance at

**[www.whalenstyle.com](http://www.whalenstyle.com)**

Or e-mail your request to **[parts@whalenfurniture.com](mailto:parts@whalenfurniture.com)**

**THIS INSTRUCTION BOOKLET CONTAINS IMPORTANT SAFETY INFORMATION.  
PLEASE READ AND KEEP FOR FUTURE REFERENCE.**

## MAXIMUM RECOMMENDED WEIGHT LOADS

MANUFACTURER: Whalen Furniture Manufacturing

CATALOG: Kitchen Cart

MODEL: PWS336158813031

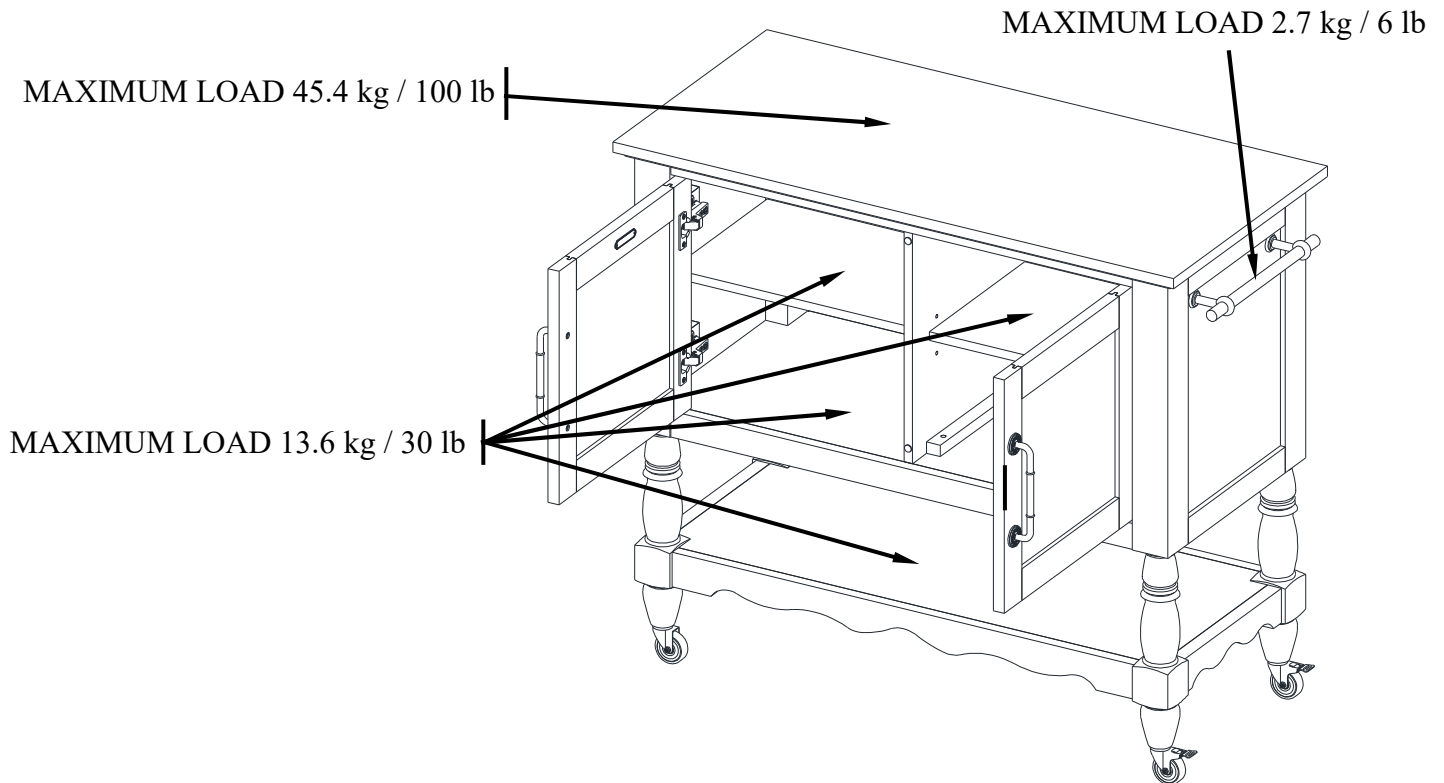

**WARNING** THIS UNIT IS INTENDED ONLY FOR USE WITHIN THE MAXIMUM WEIGHTS INDICATED. USE WITH LOAD HEAVIER THAN THE MAXIMUM WEIGHTS INDICATED MAY RESULT IN INSTABILITY, CAUSING POSSIBLE INJURY.

### How to adjust the European adjustable hinges on doors

Shipping may cause doors to go out of alignment. If you find that the doors need to be adjusted slightly, turn the appropriate screw as illustrated.

1. TO ADJUST DOOR FORWARD OR BACKWARD.
2. TO ADJUST DOOR TO RIGHT OR TO LEFT.
3. TO ADJUST DOOR UP OR DOWN.

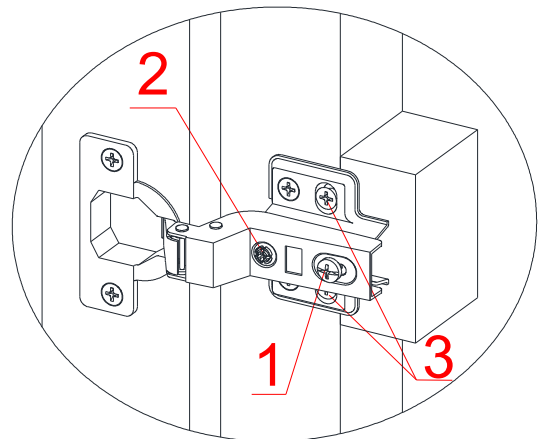

## Parts and Hardware List

Please read completely through the instructions and verify that all listed parts and hardware are present before beginning assembly.

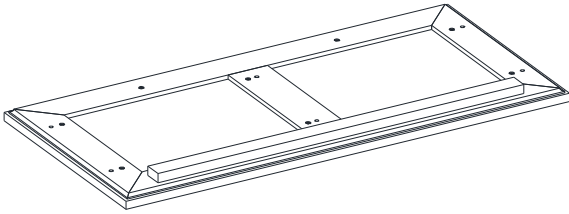

A- Top Panel (Qty. 1)

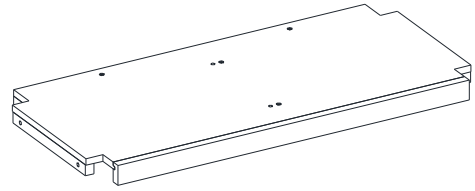

B- Fixed Shelf (1)

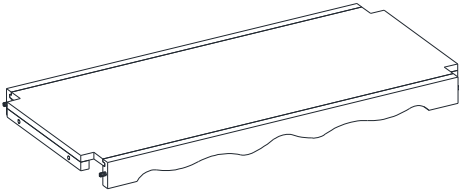

C- Open Shelf (1)

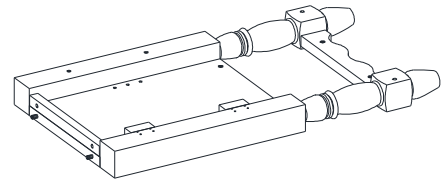

D- Left Side Frame (Qty. 1)

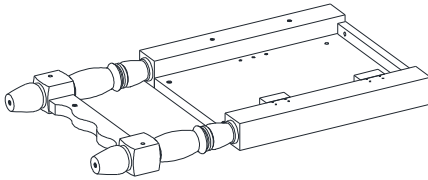

E- Right Side Frame (1)

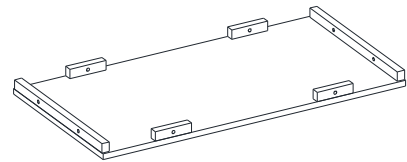

F- Back Panel (1)

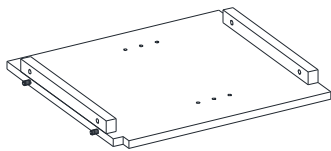

G- Partition Panel (Qty. 1)

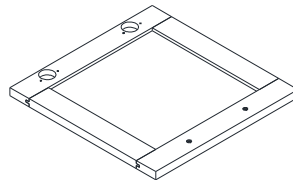

H- Door (Qty. 2)

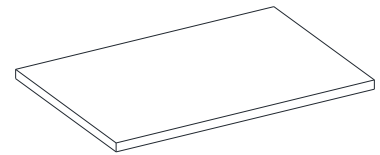

I- Adjustable Shelf (Qty. 2)

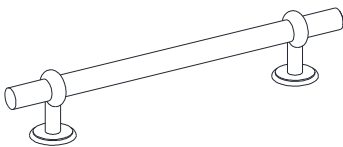

J- Side Handle (Qty. 1)

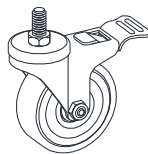

K- Lockable Caster (Qty. 2)

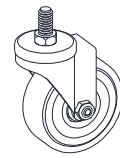

L- Swivel Caster (Qty. 2)

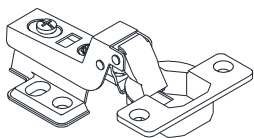

M- Door Hinge (Qty. 4)

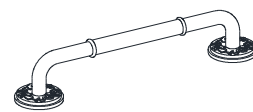

N- Door Handle (Qty. 2)

## Parts and Hardware List

Please read completely through the instructions and verify that all listed parts and hardware are present before beginning assembly.

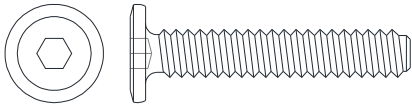

(1) 1/4" x 35 mm Bolt  
(Qty. 24+1 extra)



(2) Lock Washer  
(Qty. 24+1 extra)

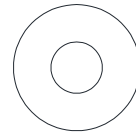

(3) Flat Washer  
(Qty. 24+1 extra)

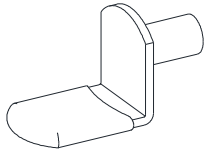

(4) Shelf Support  
(Qty. 8+1 extra)

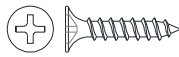

(5) M3.5 x 15 mm Nickel Screw  
(Qty. 24+1 extra)

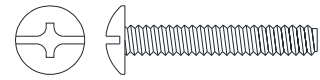

(6) 5/32" x 25 mm Bolt  
(Qty. 4)

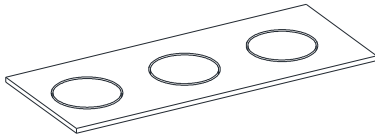

(7) Rubber Bumper  
(Qty. 2+1 extra)

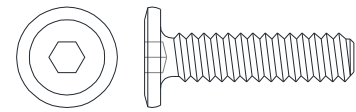

(8) 1/4" x 25 mm Bolt  
(Qty. 2+1 extra)

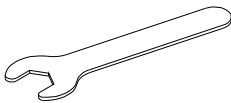

Open Wrench (Qty. 1)

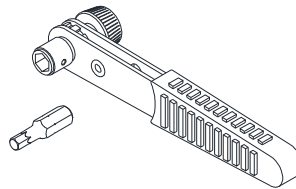

Ratchet Wrench (Qty. 1)

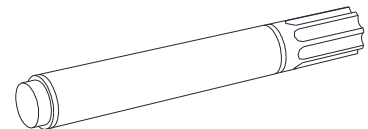

Touch-up Pen (Qty. 1)

Tools required: Open wrench and ratchet wrench (provided) and Phillips screwdriver (not provided).

## Assembly Instructions

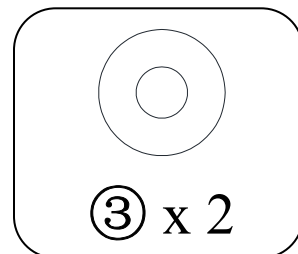
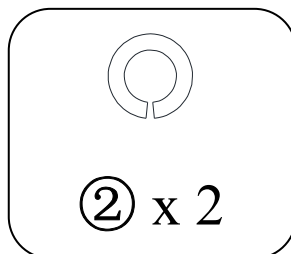
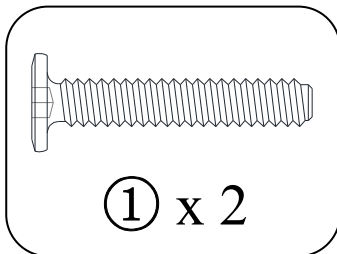
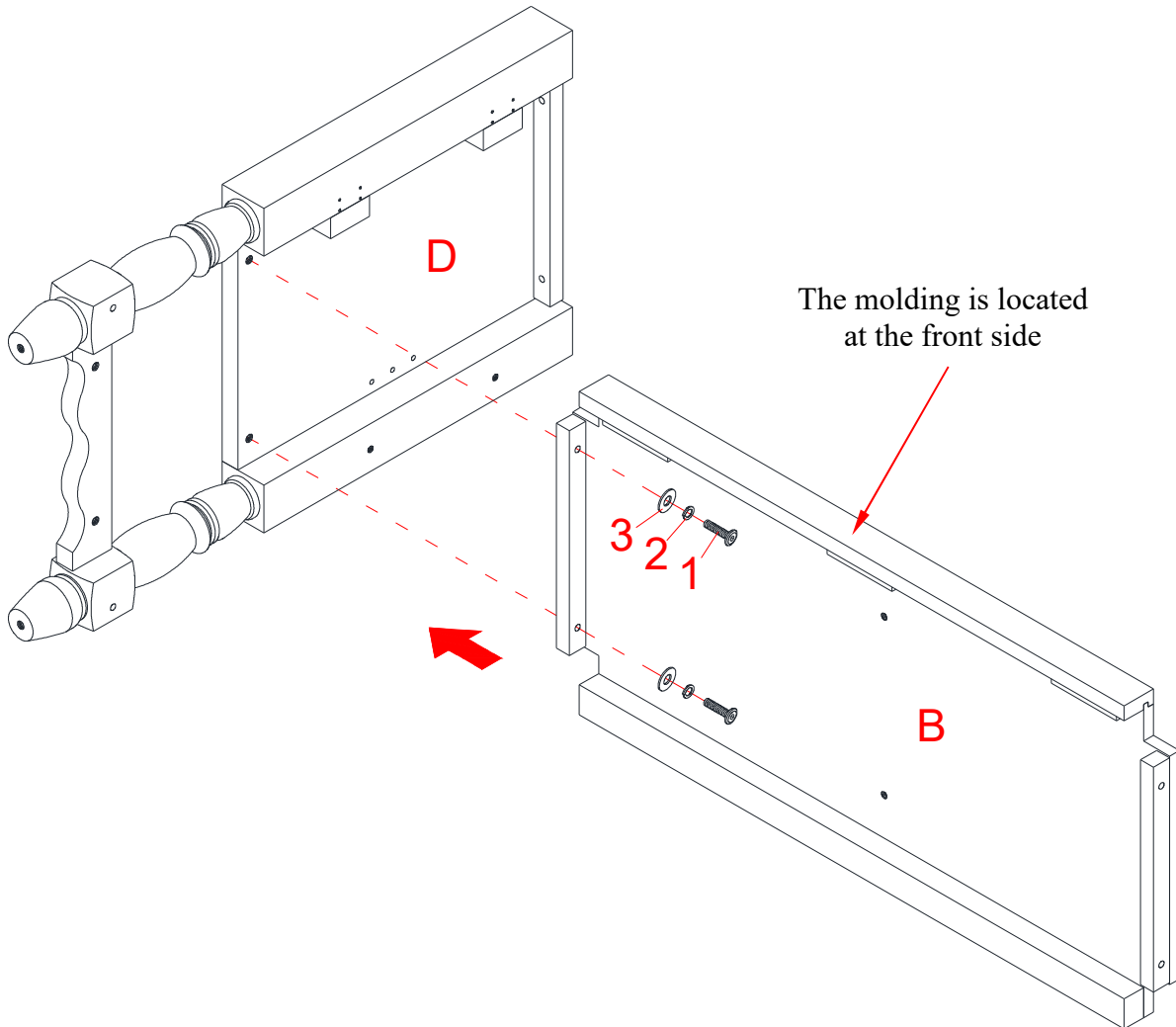

**⚠ WARNING** DO NOT fully tighten the bolts or screws initially until all the bolts or screws are ready to assemble. To avoid causing damages to the thread, DO NOT over-tighten the bolts or screws.

1. Unpack the unit and confirm that you have all the hardware and required parts listed. Assemble the unit on a carpeted floor or the empty carton to avoid any scratch.
2. Orient and attach the Fixed Shelf (B) to the Left Side Frame (D) with two 35 mm Bolts (1), two Lock Washers (2) and two Flat Washers (3). Tighten the bolts with the Ratchet Wrench provided.

# Assembly Instructions

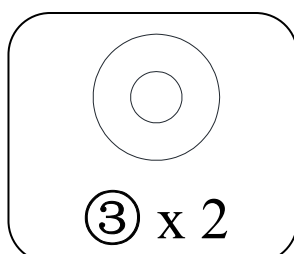
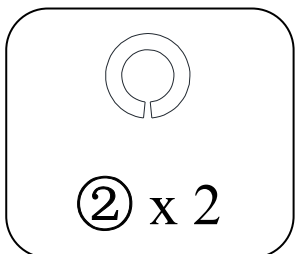
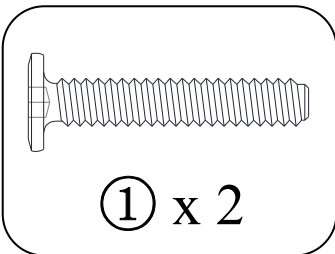
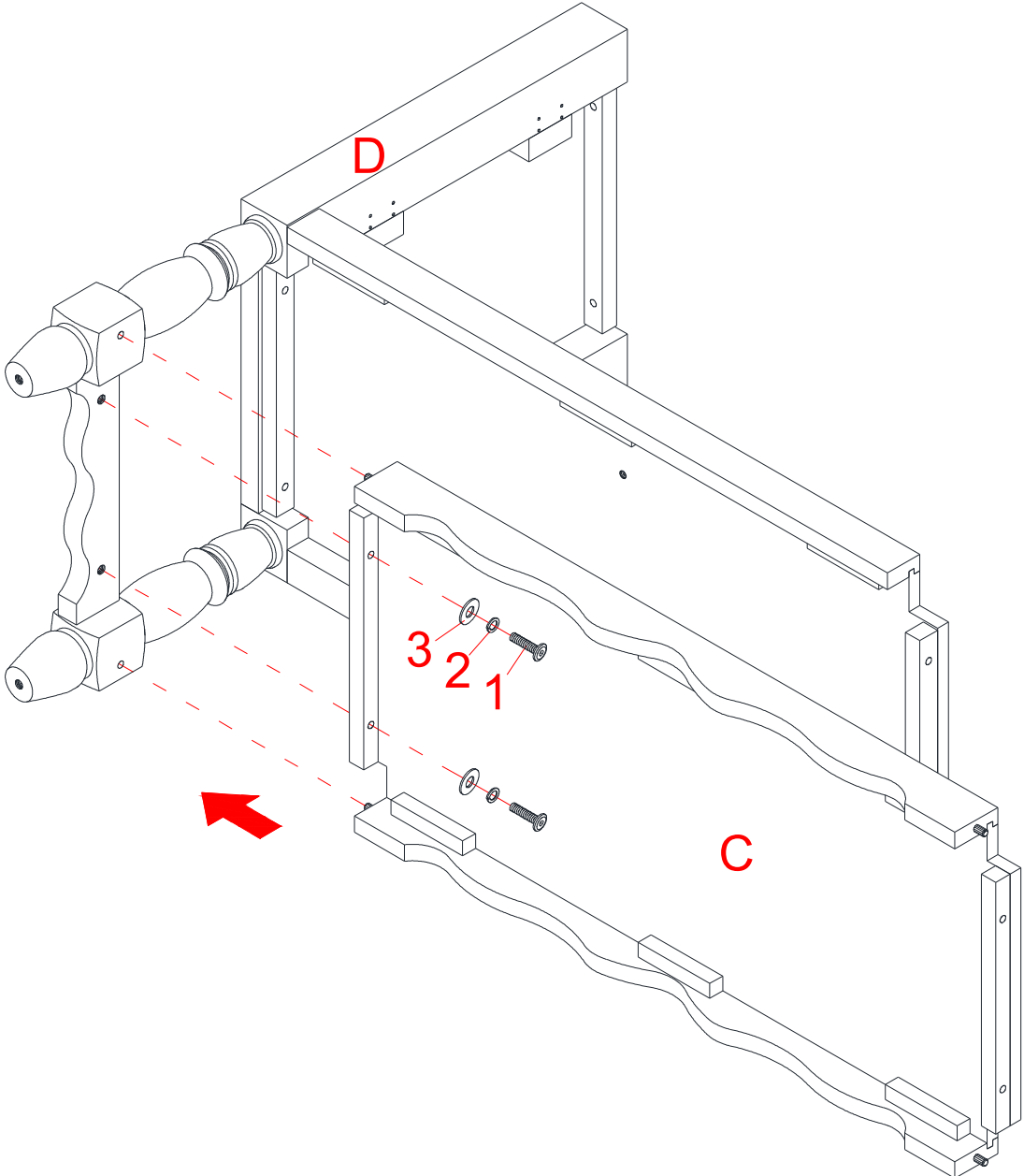

3. Using the wood dowels as a guide, align and attach the Open Shelf (C) to the Left Side Frame (D) with two 35 mm Bolts (1), two Lock Washers (2) and two Flat Washers (3).

# Assembly Instructions

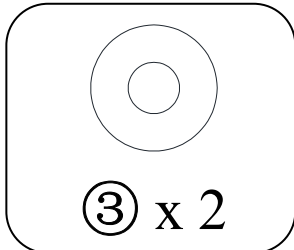
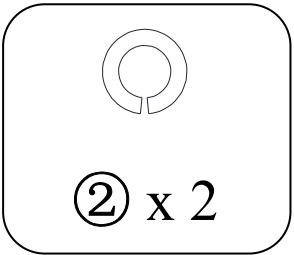
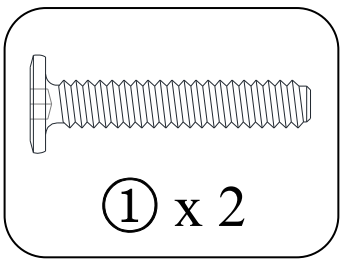
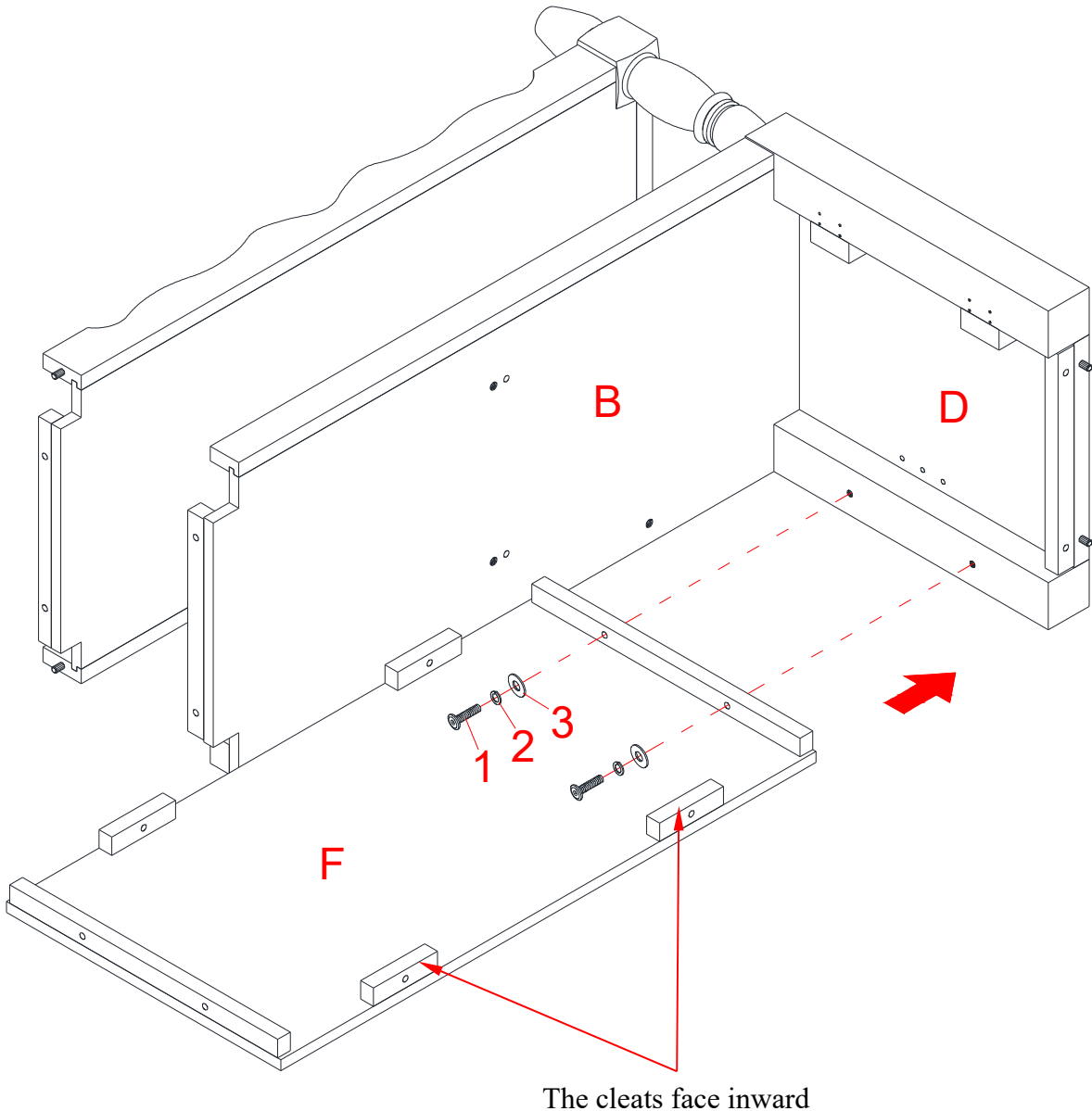

- 4. Orient and attach the Back Panel (F) to the Left Side Frame (D) with two 35 mm Bolts (1), two Lock Washers (2) and two Flat Washers (3).

# Assembly Instructions

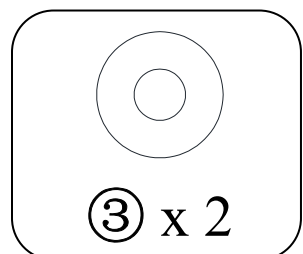
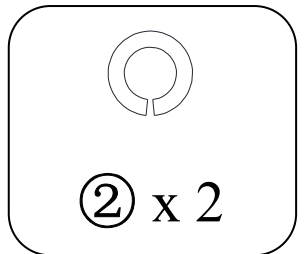
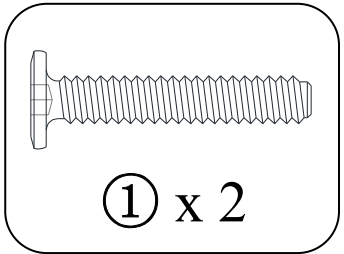
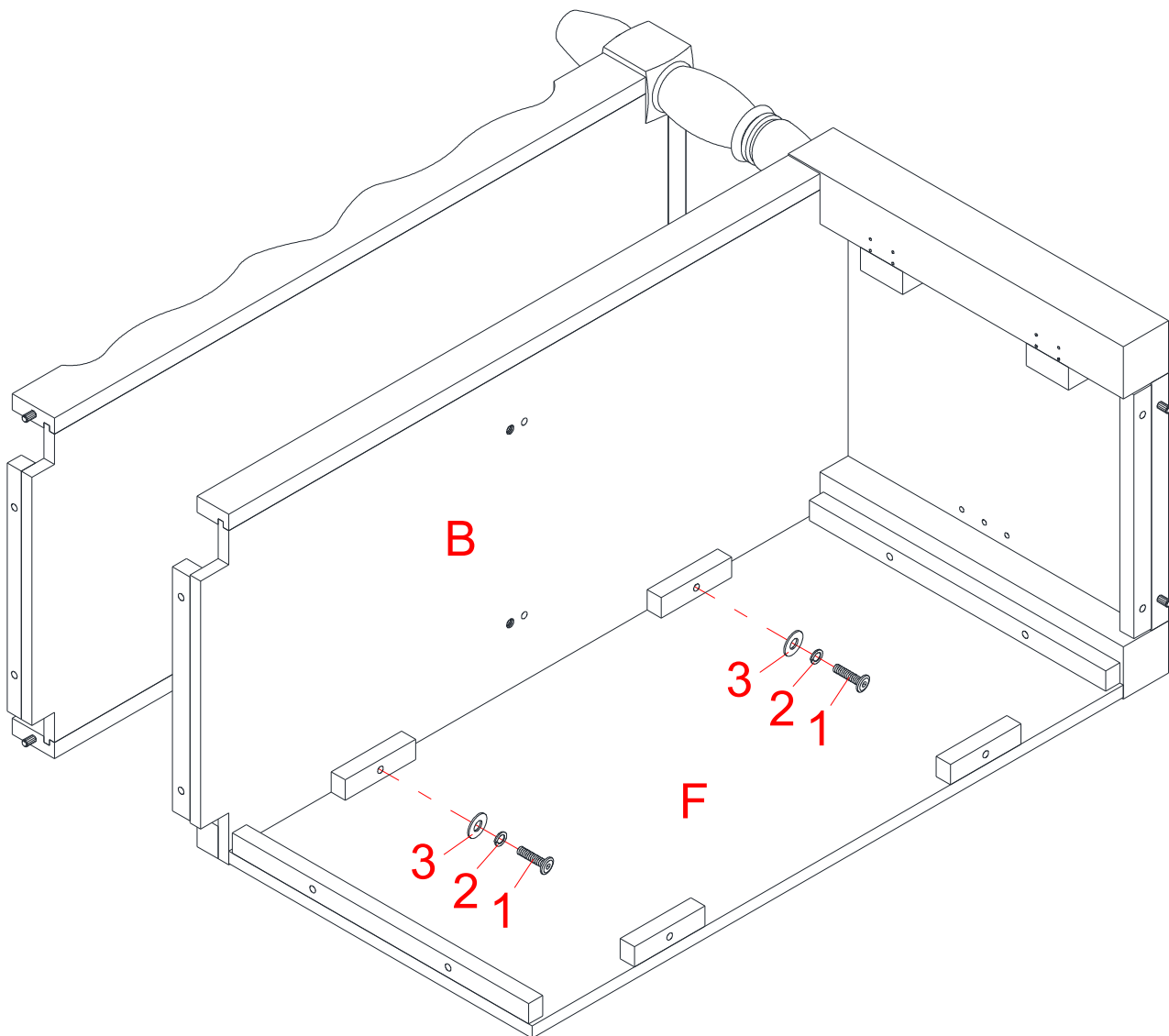

5. Insert two 35 mm Bolts (1) with the Washers (2 and 3) through the cleats on Back Panel (F) and screw into the threaded inserts on the Fixed Shelf (B).



# Assembly Instructions

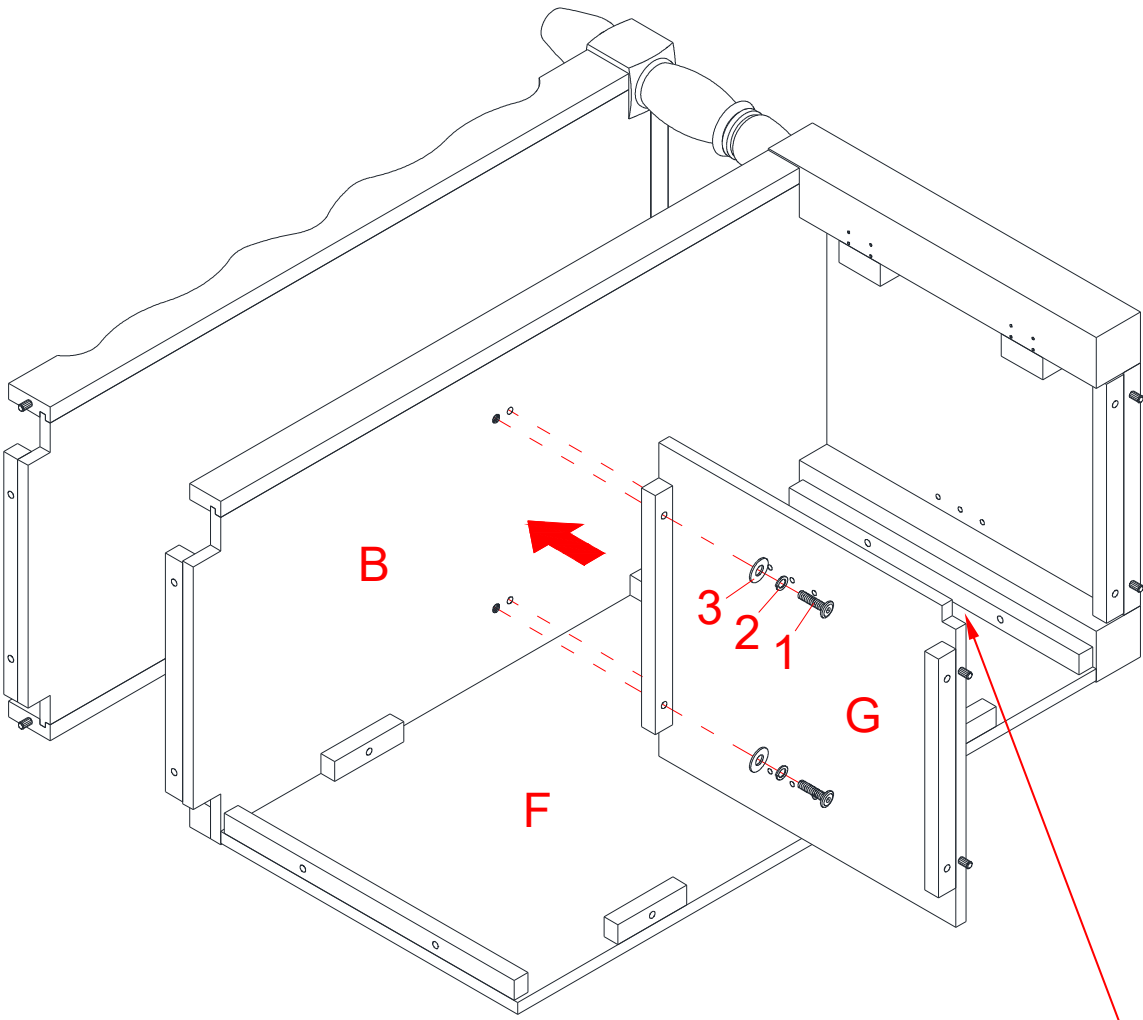

The notch faces upward

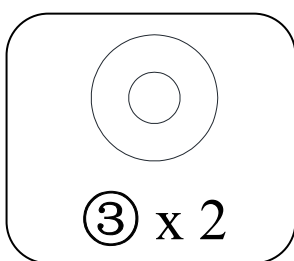
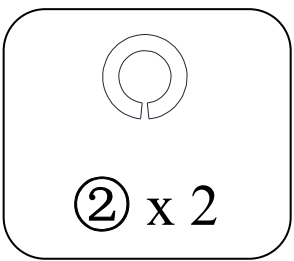
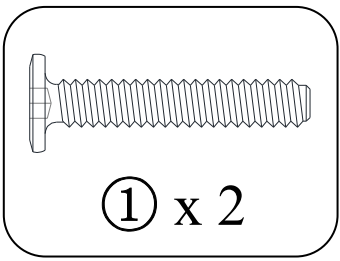

6. Orient and attach the Partition Panel (G) to the Fixed Shelf (B) with two 35 mm Bolts (1), two Lock Washers (2) and two Flat Washers (3).

# Assembly Instructions

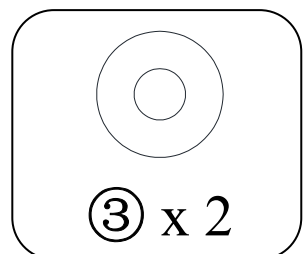
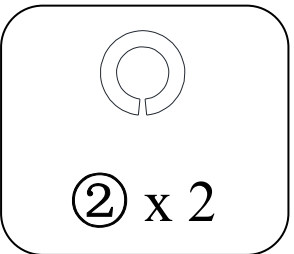
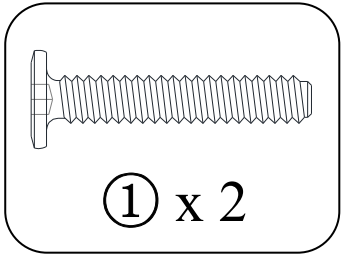
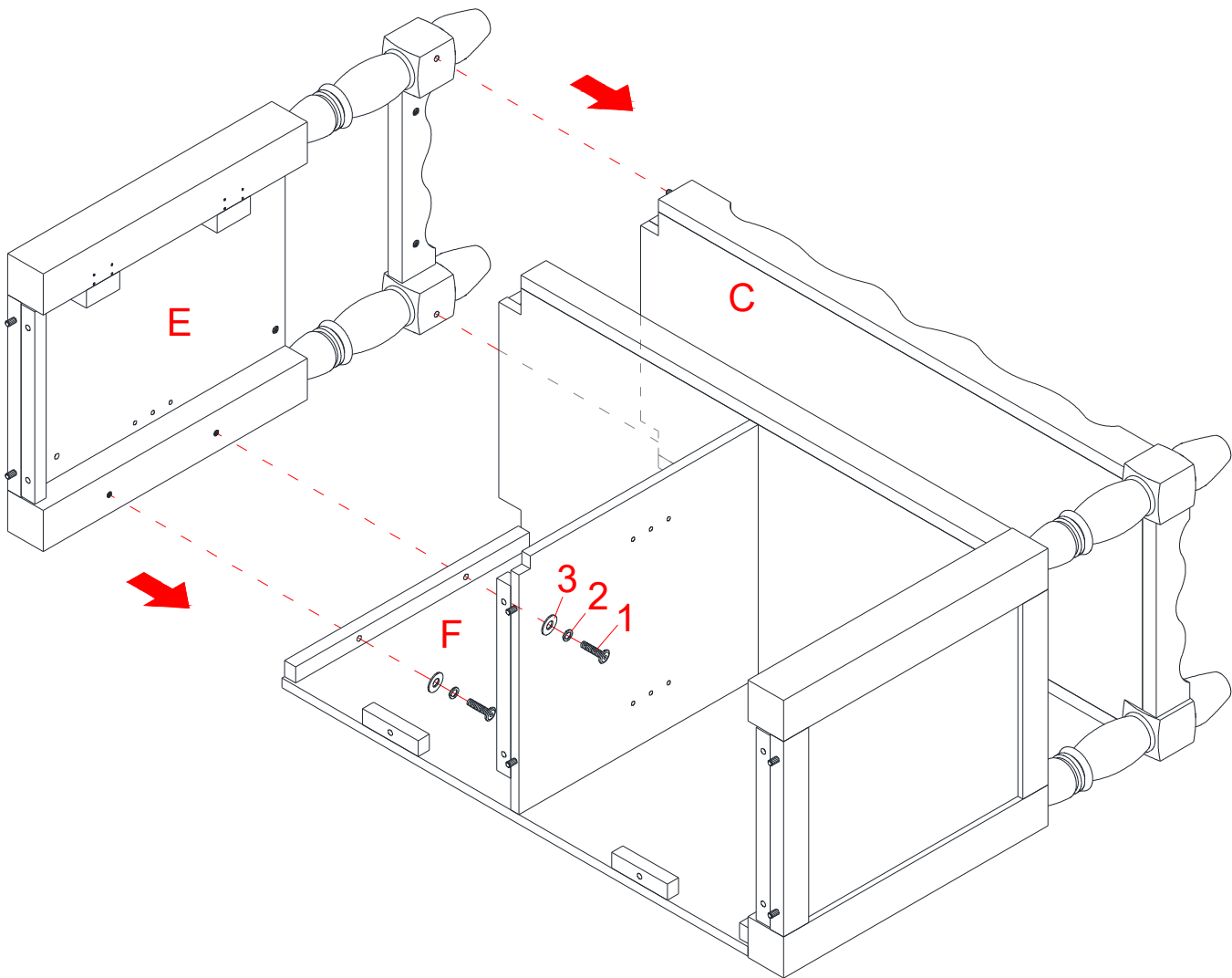

7. Using the wood dowels as a guide, align and attach the Right Side Frame (E) to the assembled Back Panel (F) with two 35 mm Bolts (1), two Lock Washers (2) and two Flat Washers (3).

## Assembly Instructions

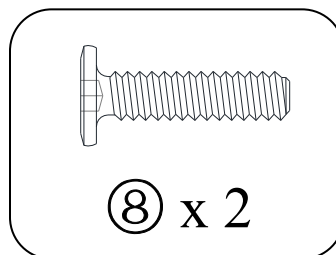
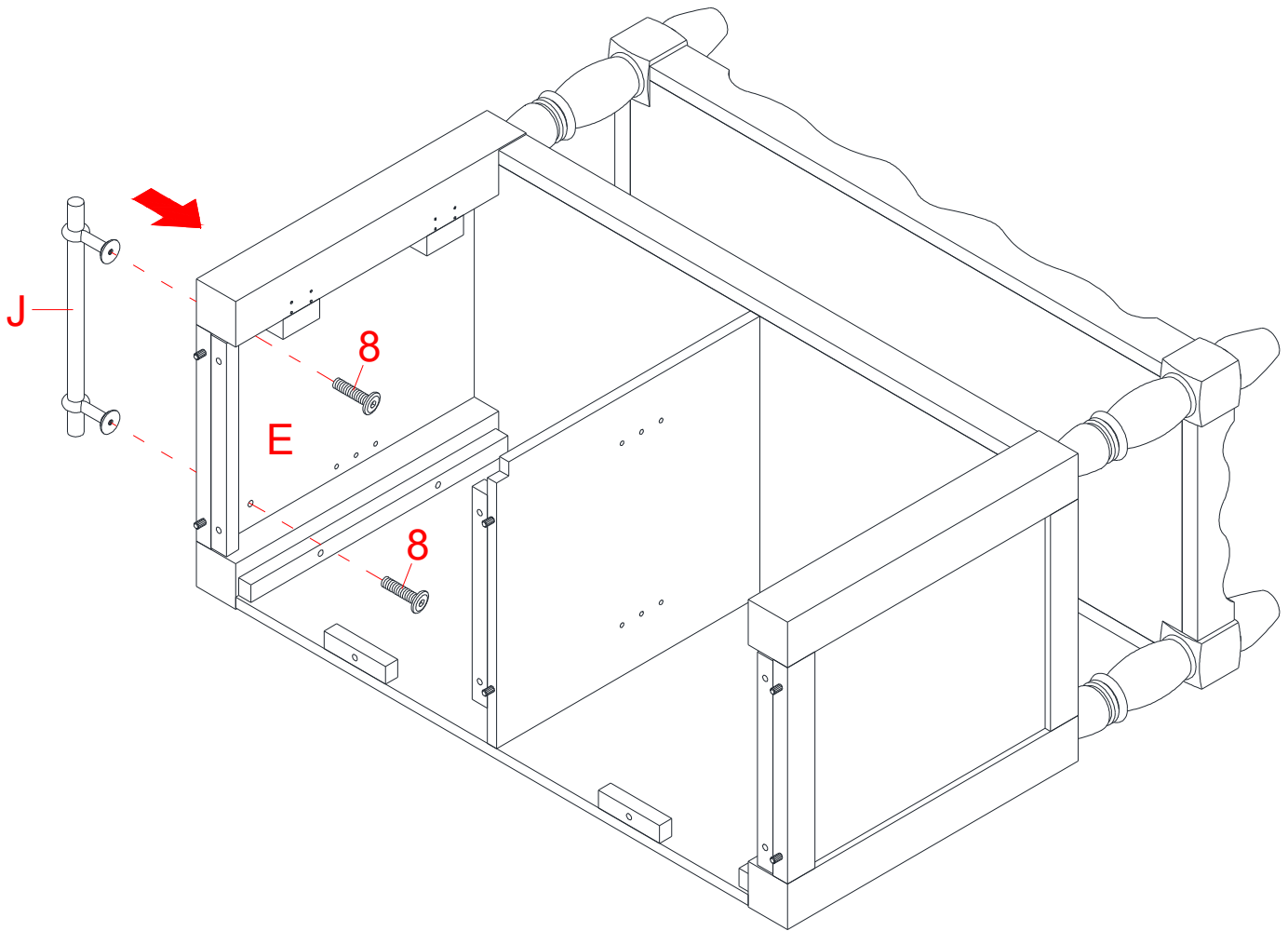

8. Attach the Side Handle (J) to the Right Side Frame (E) with two 25 mm Bolts (8).
9. You can hang your rags or kitchen towel on the Side Handle (J) for a quick access.

# Assembly Instructions

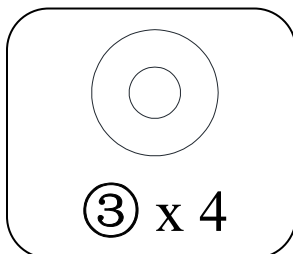
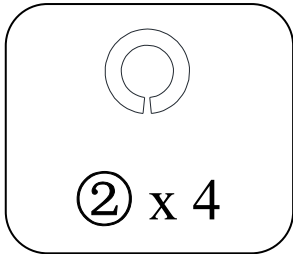
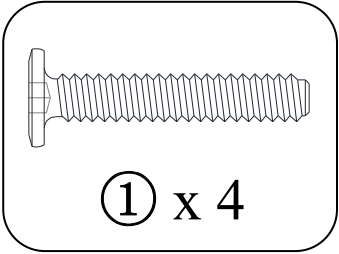
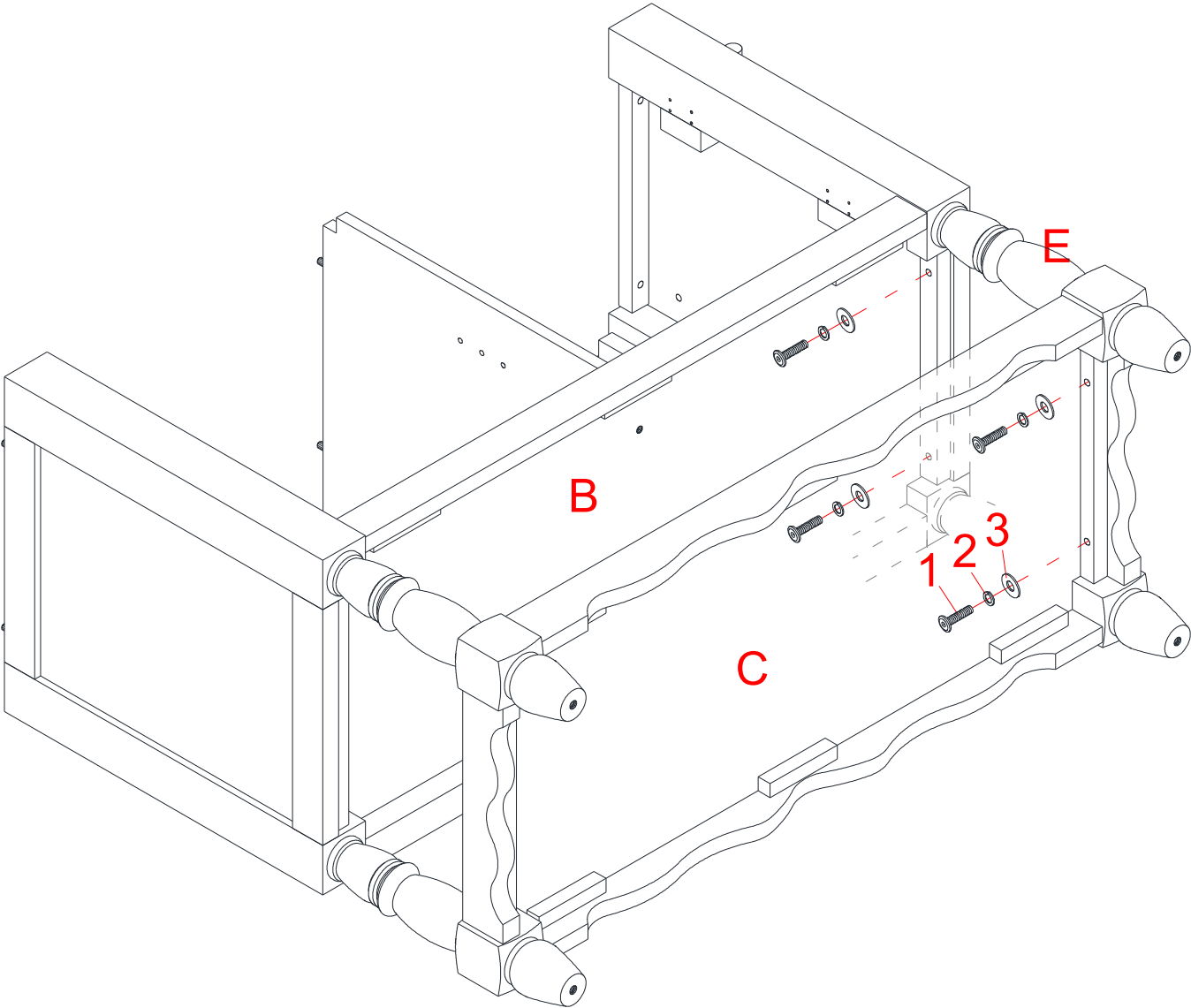

10. Secure the Right Side Frame (E) to both Fixed Shelf (B) and Open Shelf (C) with four 35 mm Bolts (1), four Lock Washers (2) and four Flat Washers (3). **DO NOT** fully tighten the bolts.

## Assembly Instructions

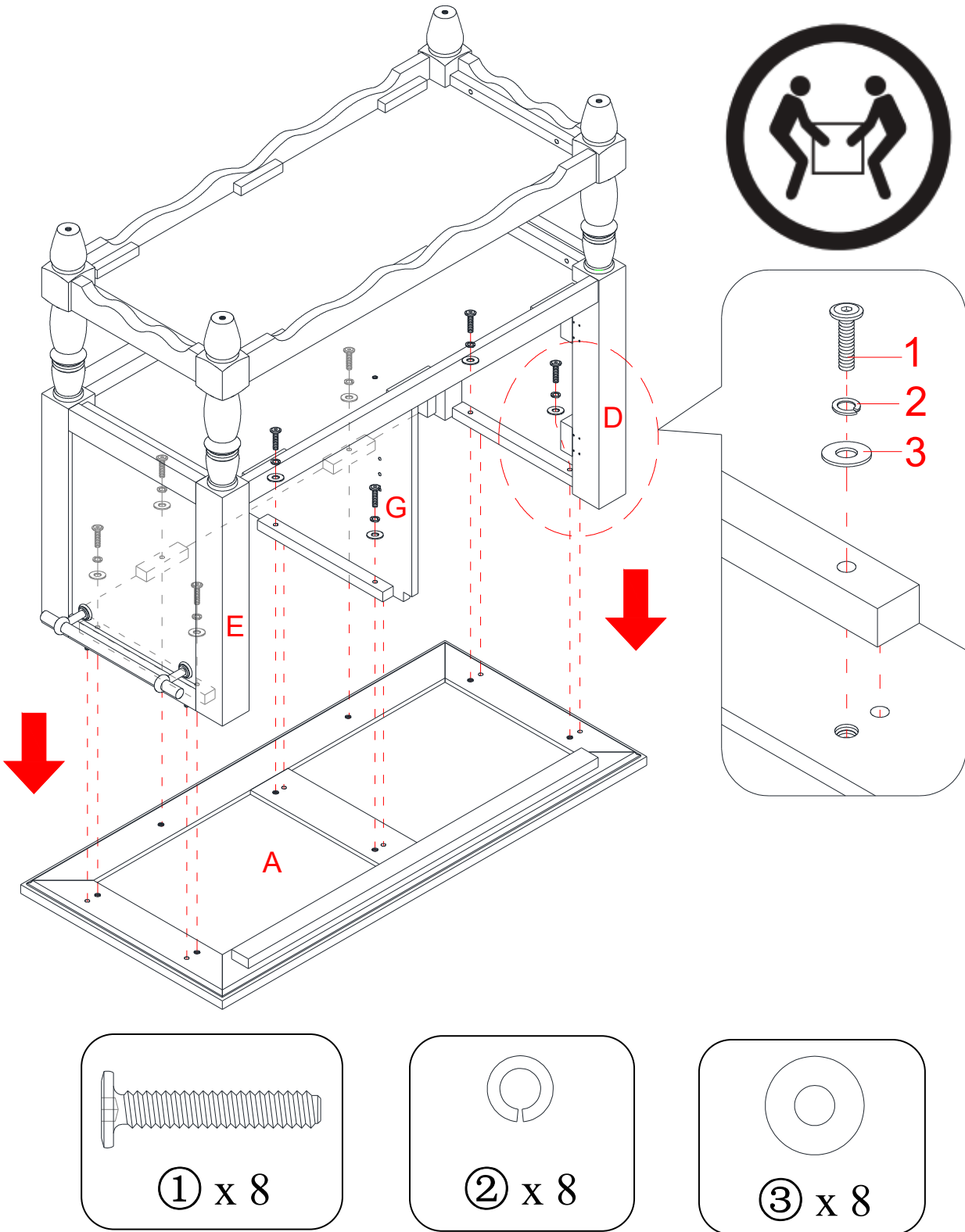

11. Lay the Top Panel (A) upside down on a level and protective surface.

12. Using the wood dowels as a guide, align the previous assembly to the Top Panel (A) properly and attach them into place with eight 35 mm Bolts (1), eight Lock Washers (2) and eight Flat Washers (3). Tighten the bolts into place with the Ratchet Wrench provided.

# Assembly Instructions

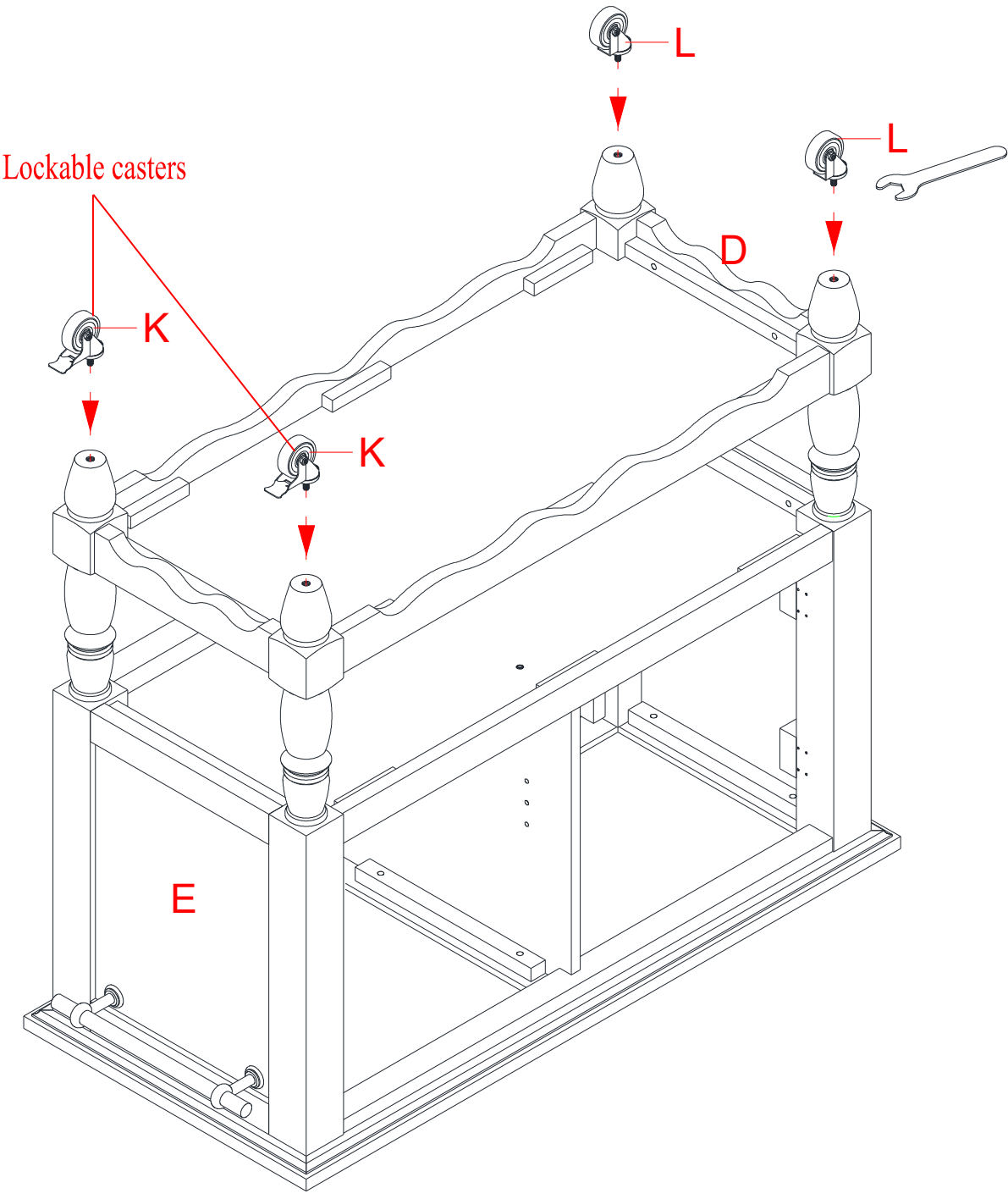

- 13. Fasten the Casters (K and L) to the bottom of both Side Frames (D and E) using the open wrench enclosed. Make sure that two Lockable Casters (K) are located at the right side.
- 14. Two Lockable Casters (K) make the cart freely stop at your will. Step on the brake to lock the Casters (K) in place for safe, stable use.

# Assembly Instructions

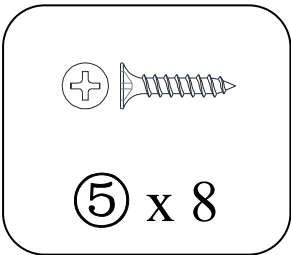
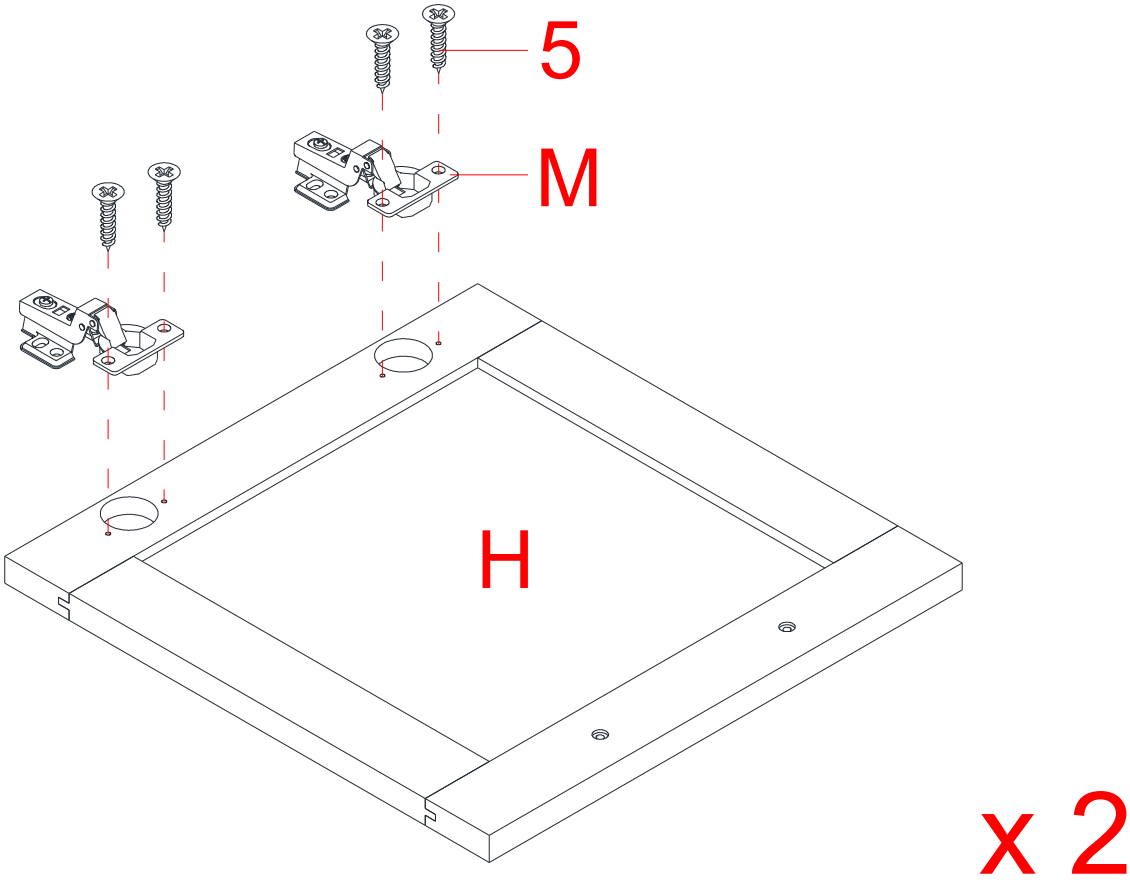

- 15. Extend two Door Hinges (M) and rest the hinge cups onto the cutouts of one Door (H). Secure the Door Hinges (M) in place by using two 15 mm Screws (5) in each.
- 16. Complete this step 2 times to assemble the other Door (H).

# Assembly Instructions

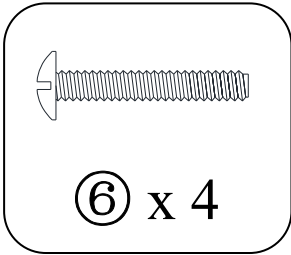
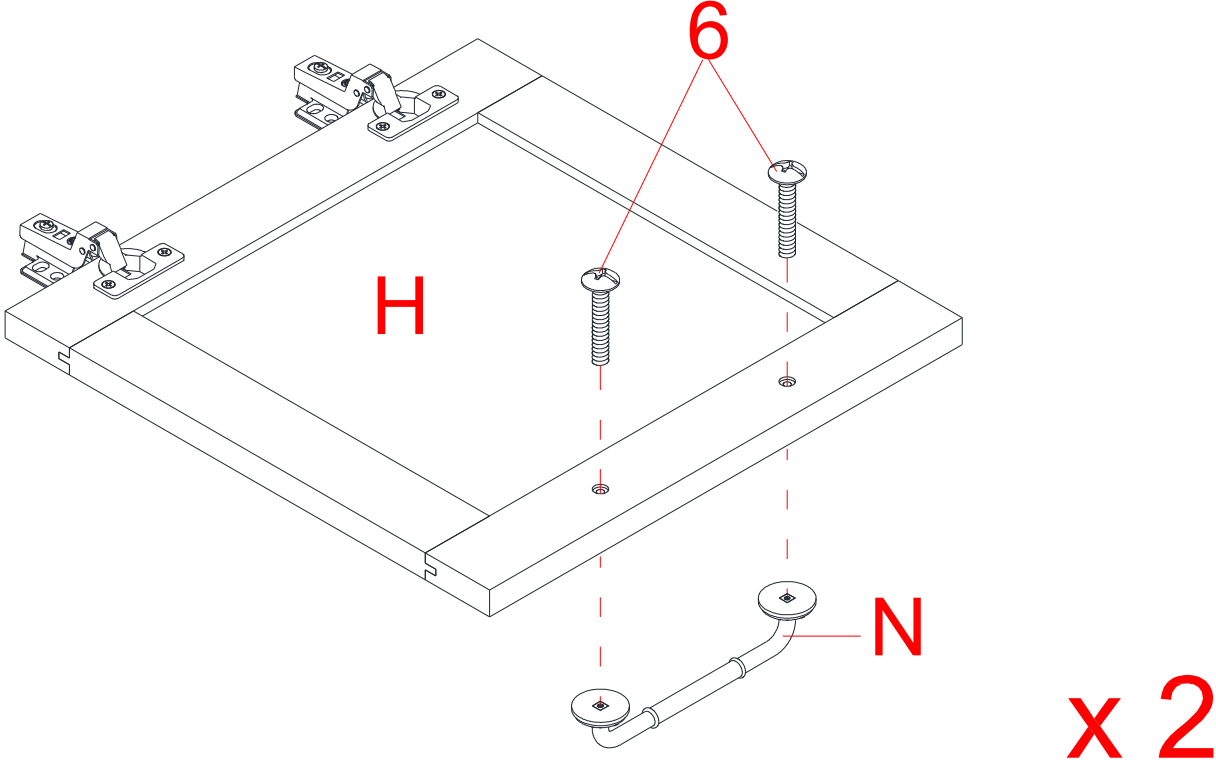

17. Attach one Door Handle (N) to the outside of each Door (H) with two 25 mm Bolts (6).



## Assembly Instructions

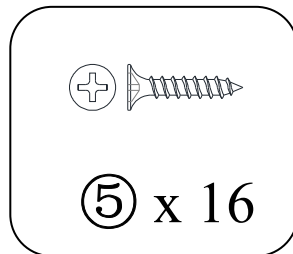
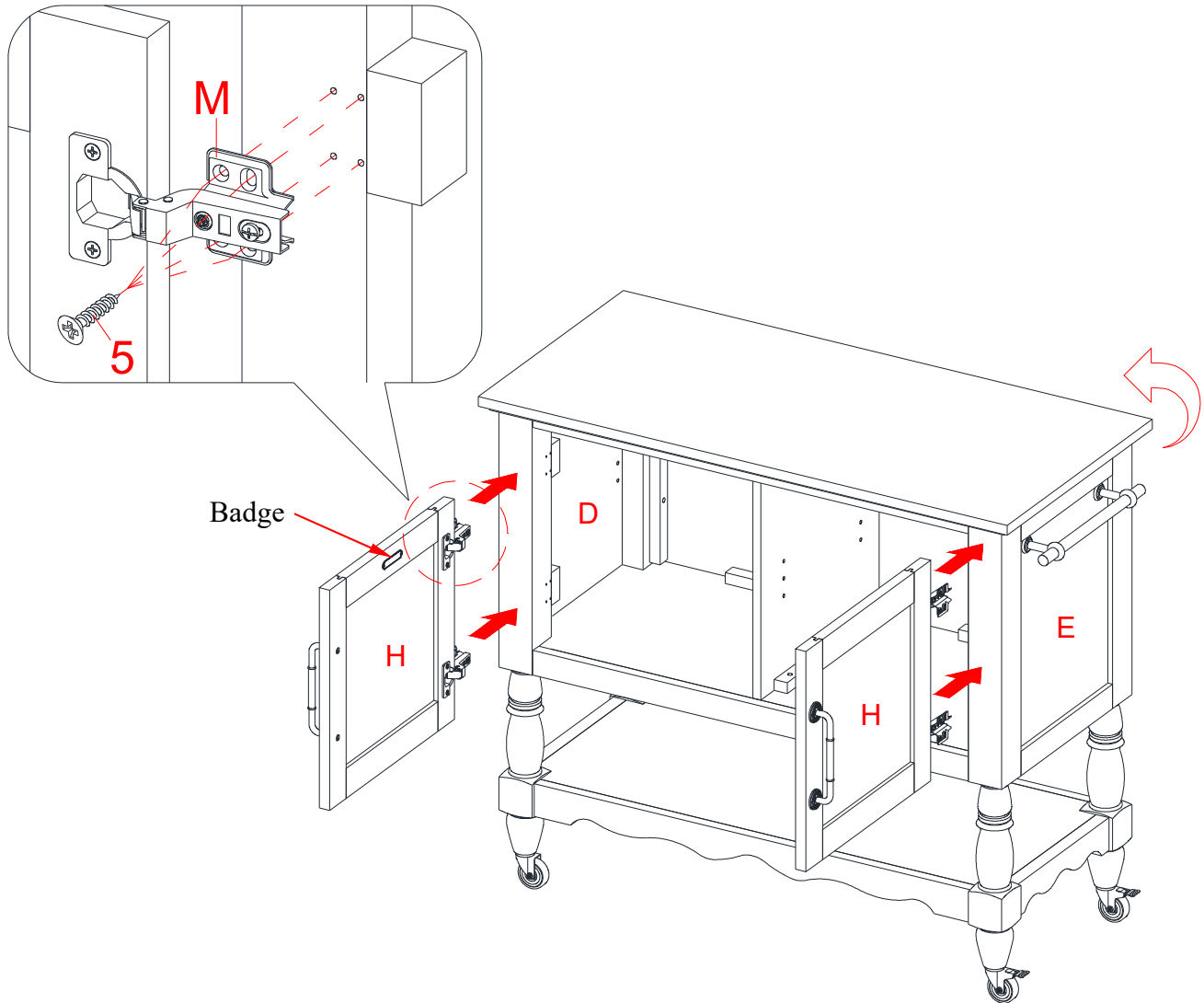

18. Ask for assistance to lift the assembled unit upright and position it near the final location.
19. Pick up the Door (H) with badge and attach the extended Door Hinges (M) to the Left Side Frame (D) with eight 15 mm Screws (5), using the pilot holes as a guide. Make sure that both door hinges engage and function properly.
20. Repeat the same procedure to attach the other Door (H) to the Right Side Frame (E).
21. Open and close the doors to make sure they are aligned and shut correctly. If necessary, adjust the screws for a good fit. Refer to the hinge sticker on door for adjustment.

## Assembly Instructions

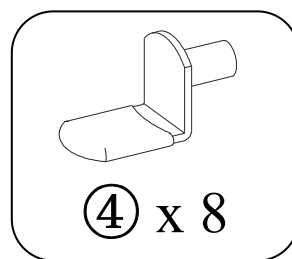
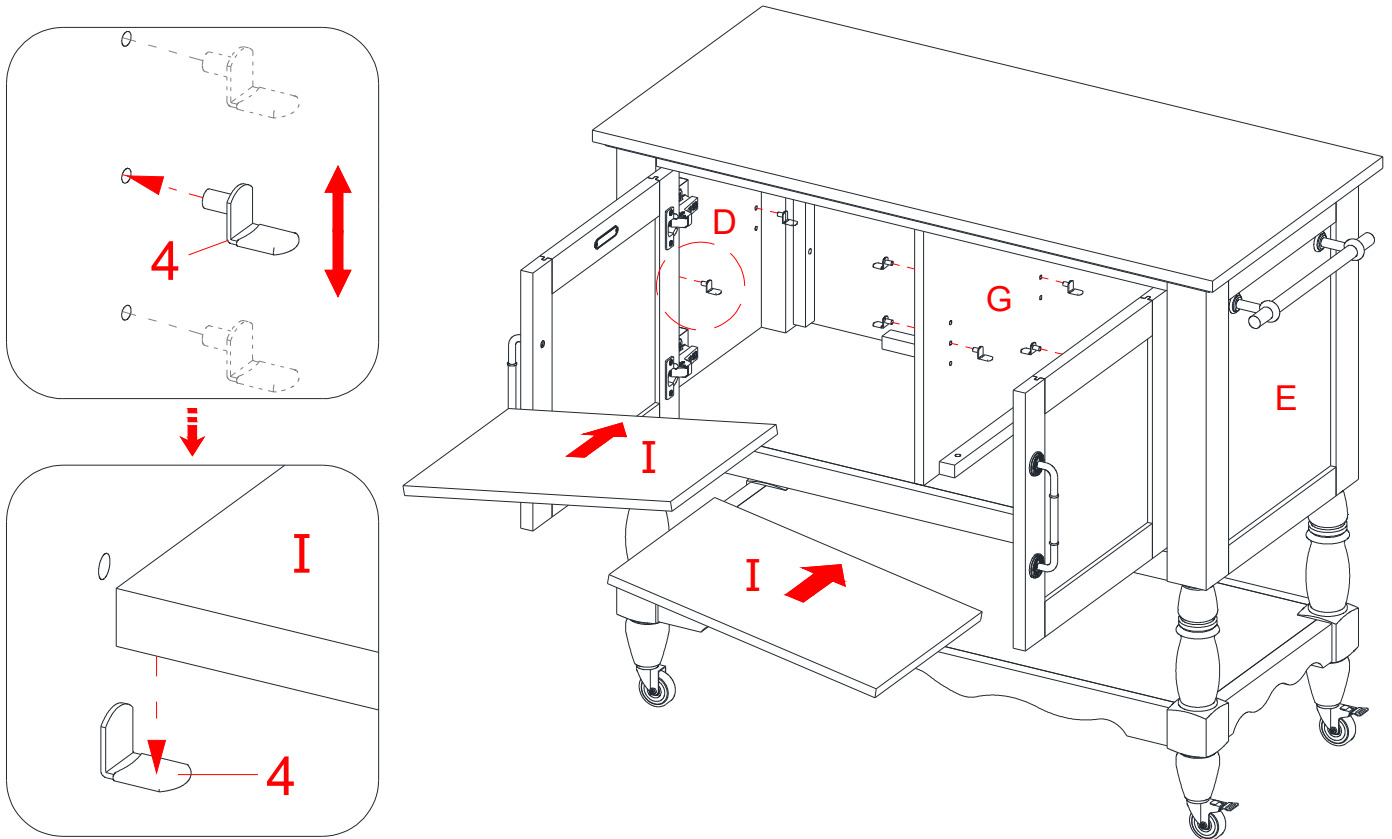

22. Insert four Shelf Supports (4) into the holes at the desired height inside each compartment. Make sure you place the four Shelf Supports at the same level to level the shelf.
23. Tilt and rest the Adjustable Shelves (I) onto the Shelf Supports (4).

# Assembly Instructions

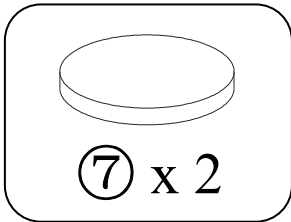
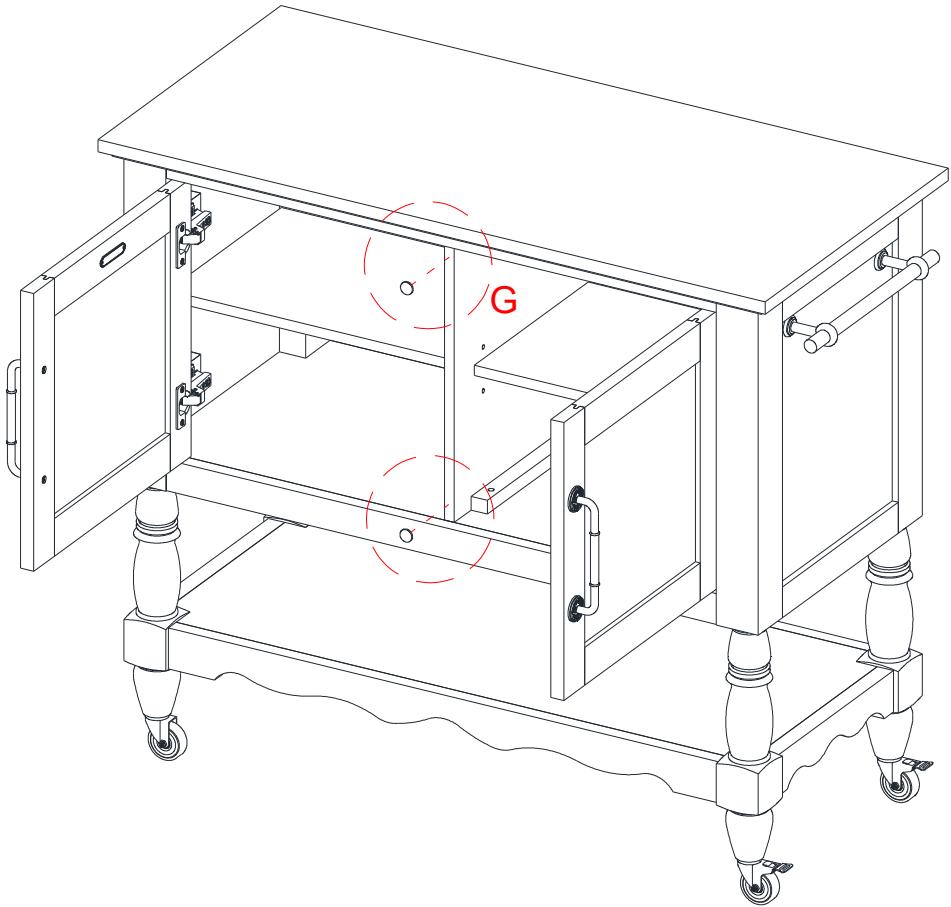
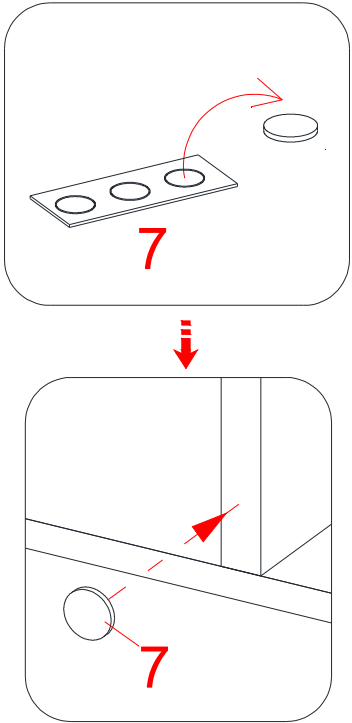

24. Peel off the Rubber Bumpers (7) from the bumper card and stick them at the front edge of the Partition Panel (G) where they come in contact with the Doors (H).

## Care and Maintenance

- Use a soft, clean cloth that will not scratch the surface when dusting.
- Use of furniture polishes is not necessary. Should you choose to use polishes, test first in an inconspicuous area.
- Using solvents of any kind on your furniture may damage the finish.
- Never use water to clean your furniture as it may cause damage to the finish.
- Always use coasters under beverage glasses and flowerpots.
- Liquid spills should be removed immediately. Using a soft, clean cloth, blot the spill gently. Avoid rubbing.
- Always use protective pads under hot dishes and plates. Heat can cause chemical changes that may create spotting within the furniture finish.
- Stains or marks from crayons or ink markers will be difficult to remove.
- In the event that your furniture is stained or otherwise damaged during use, we recommend that you call a professional to repair your furniture.
- Check bolts/screws periodically and tighten them if necessary.

## Further advice about wood furniture care

It is best to keep your furniture in a climate-controlled environment. Extreme temperature and humidity changes can cause fading, warping, shrinking, and splitting of wood. It is advised to keep furniture away from direct sunlight as sun may damage the finish.

Proper care and cleaning at home will extend the life of your purchase. Following these important and helpful tips will enhance your furniture as it ages.

**A touch-up pen has been provided to minimize the small nicks or scratches that may occur during assembly or shipping.**

We hope you enjoy your purchase for many years.  
Thank you for your purchase!

## QUALITY GUARANTEE

We are confident that you will be delighted with your Whalen Furniture purchase.

Should this product be defective in workmanship or materials or fail under normal use, we will repair or replace it for up to one (1) year from date of purchase. Every Whalen Furniture product is designed to meet your highest expectations. We guarantee that you will immediately see the value of our fine furniture.

This warranty gives you specific legal rights and you may also have other rights which vary from state to state.

Whalen Furniture Manufacturing  
1578 Air Wing Road, San Diego, CA 92154, USA  
Customer Service: 1-866-942-5362  
8:30 a.m. - 4:30 p.m., PST, Monday to Friday  
**[www.whalenstyle.com](http://www.whalenstyle.com)**

# Carro para cocina

Serie # PWS336158813031



## **ENSAMBLE REQUERIDO POR ADULTO**

Si tienen alguna pregunta acerca del ensamble o si alguna parte está faltante, no retorne este producto a la tienda donde lo compro. Por favor llame a nuestro departamento de ayuda al cliente teniendo su instructivo y lista de partes para proveer el modelo, nombre de parte o el número de fábrica:

**1-866-942-5362**

Hora estándar del Pacífico: 8:30 a.m. - 4:30 p.m., de lunes a viernes

O visite nuestra página de Internet 24 horas al día, 7 días a la semana para asistencia

**[www.whalenstyle.com](http://www.whalenstyle.com)**

O mande un correo electrónico a **[parts@whalenfurniture.com](mailto:parts@whalenfurniture.com)**

**ESTE INSTRUCTIVO CONTIENE INFORMACION IMPORTANTE DE SEGURIDAD.  
POR FAVOR LEA Y MANTENGA PARA USO FUTURO.**

Fecha 2023-03-03 Rev. 0001-A

# MÁXIMO PESO RECOMENDADO

FABRICANTES: Whalen Furniture Manufacturing

CATALOGO: Carro para cocina

MODELO: PWS336158813031

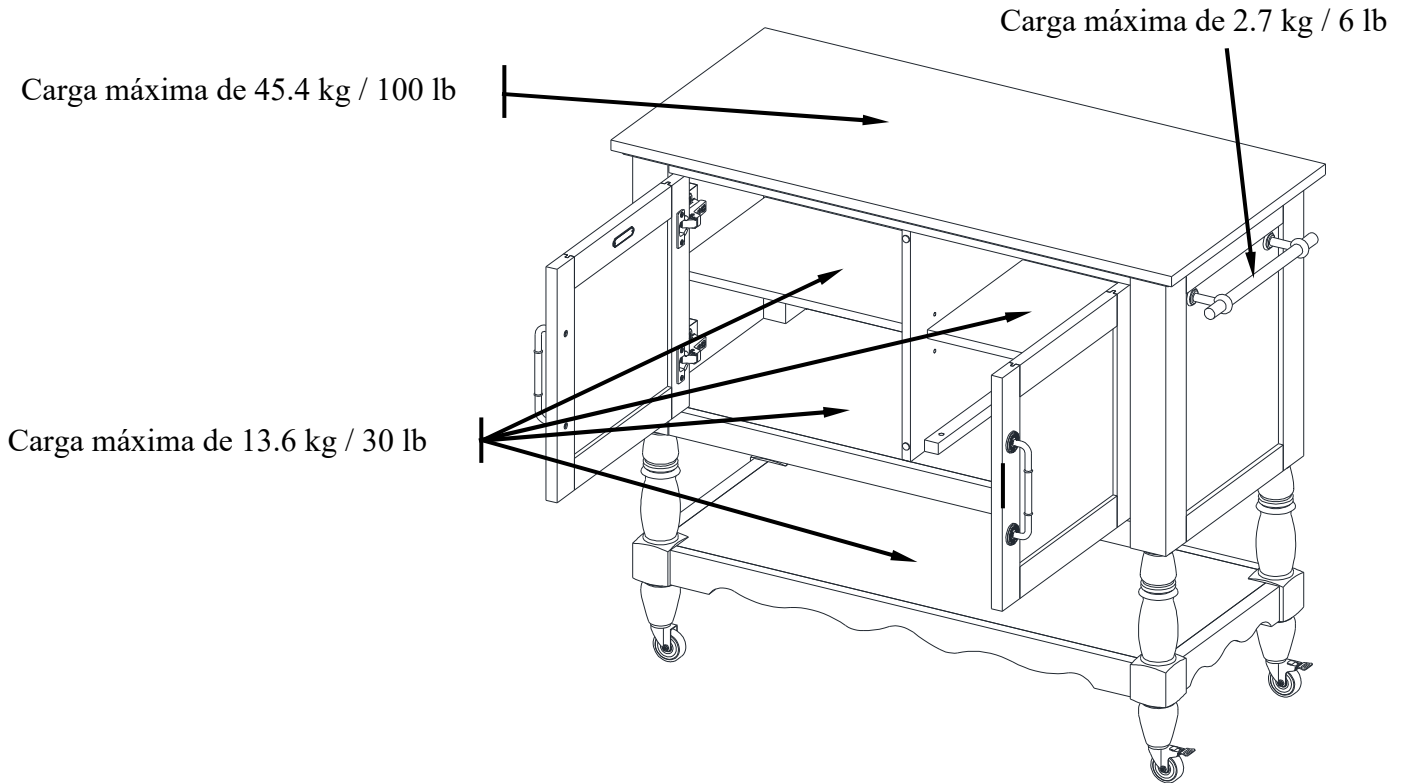

## **⚠ ADVERTENCIA**

ESTA UNIDAD DEBE UTILIZARSE CON LOS PESOS MÁXIMOS INDICADOS. SI SE EXCEDE EL PESO MÁXIMO, PODRIA RESULTAR EN UNA INESTABILIDAD DE LA UNIDAD CAUSANDO POSIBLES LESIONES.

## **Como ajustar las bisagras europeas ajustables en las puertas**

El envío puede causar que las puertas se desalineen. Si encuentra que las puertas necesitan una ajustada, gire el perno apropiado, como está ilustrado.

1. PARA AJUSTAR LA PUERTA HACIA ADELANTE O HACIA ATRAS.
2. PARA AJUSTAR LA PUERTA HACIA LA DERECHA O HACIA LA IZQUIERDA.
3. PARA AJUSTAR LA PUERTA HACIA ARRIBA O HACIA ABAJO.

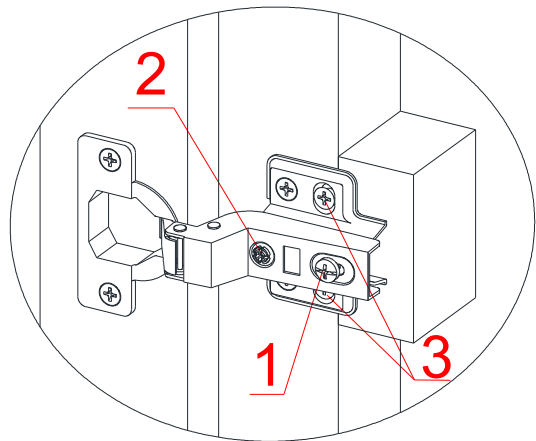

## Lista de partes y material de ferretería

Por favor lea completamente las instrucciones y verifique que estén todas las partes y partes de ferretería antes de iniciar el ensamblado.

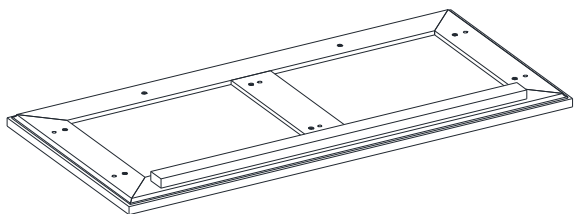

A- Panel superior (Cant. 1)

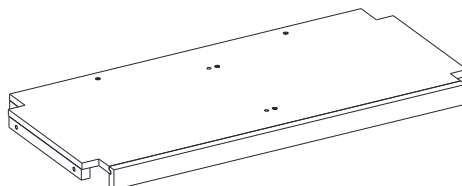

B- Repisa fija (1)

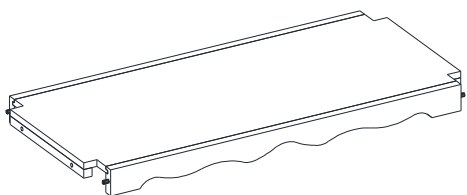

C- Repisa abierta (1)

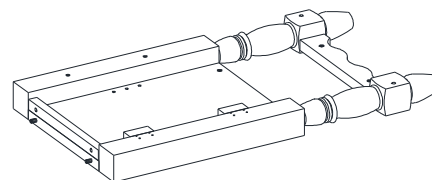

D- Marco izquierdo (Cant. 1)

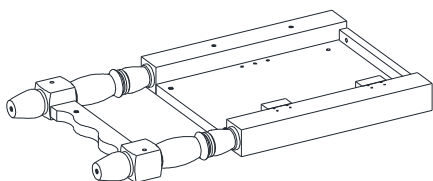

E- Marco derecho (1)

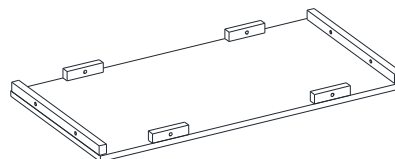

F- Panel posterior (1)

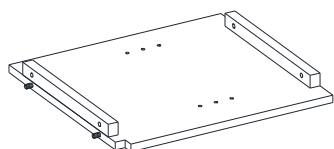

G- Panel divisor (Cant. 1)

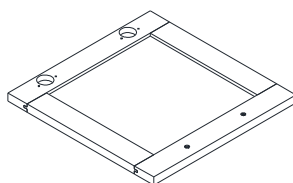

H- Puerta (Cant. 2)

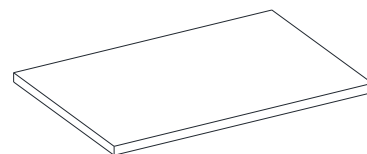

I- Repisa ajustable (Cant. 2)

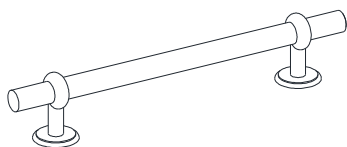

J- Manija lateral (Cant. 1)

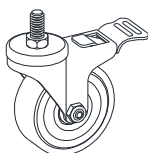

K- Rueda con tope (Cant. 2)

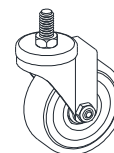

L- Rueda (Cant. 2)

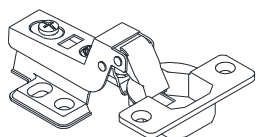

M- Bisagra para puerta (Cant. 4)

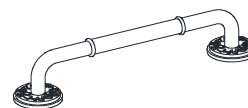

N- Manija para la puerta (Cant. 2)

## Lista de partes y material de ferretería

Por favor lea completamente las instrucciones y verifique que estén todas las partes y partes de ferretería antes de iniciar el ensamblado.

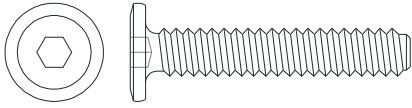

(1) Perno de 1/4 de pulgada x 35 mm  
(Cant. 24+1 extra)



(2) Arandela de presión  
(Cant. 24+1 extra)

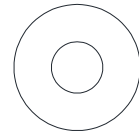

(3) Arandela plana  
(Cant. 24+1 extra)

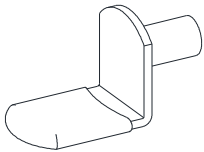

(4) Soporte para repisa  
(Cant. 8+1 extra)

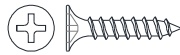

(5) Perno de níquel de M3.5 x 15 mm  
(Cant. 24+1 extra)

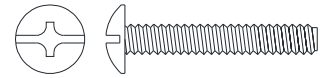

(6) Perno de 5/32 de pulgada x 25 mm  
(Cant. 4)

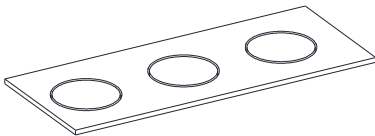

(7) Tope de plástico  
(Cant. 2+1 extra)

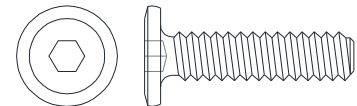

(8) Perno de 1/4 de pulgada x 25 mm  
(Cant. 2+1 extra)

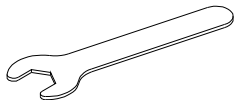

Llave española (Cant. 1)

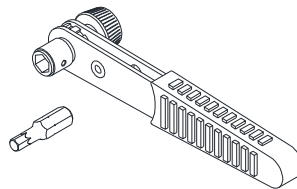

Llave de trinquete (Cant. 1)

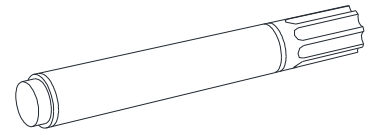

Bolígrafo de retoque (Cant. 1)

Herramientas requeridas: Llave española y llave de trinquete (provistas) y desarmador estrella (no provista).



## Instructivo de ensamble

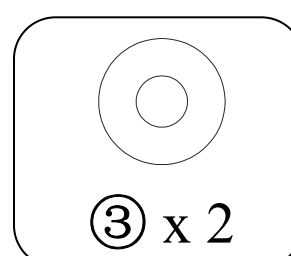
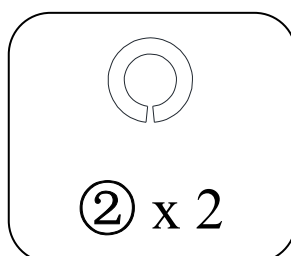
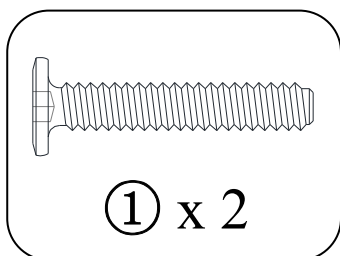
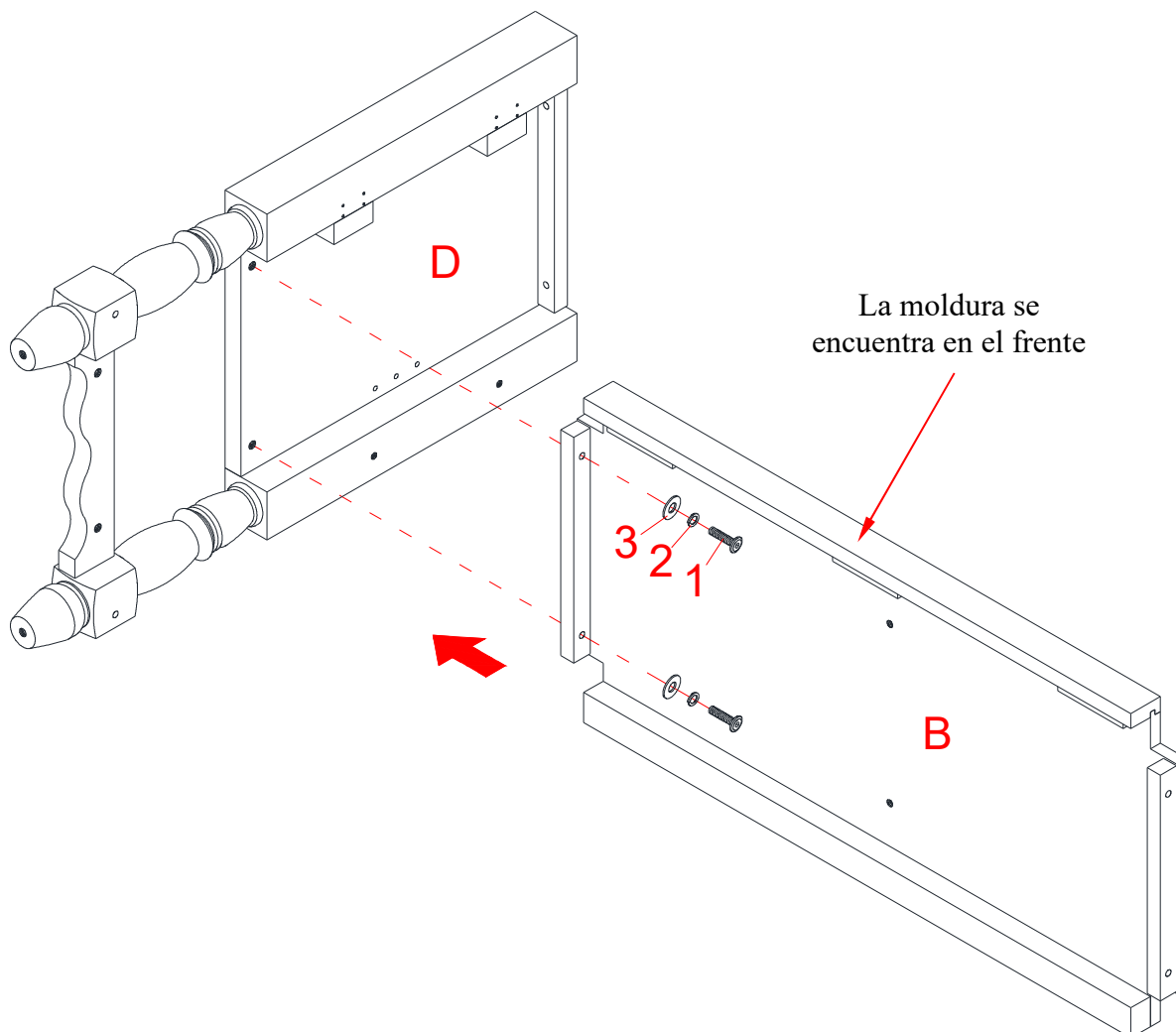

### **⚠ ADVERTENCIA**

NO apriete los pernos y tornillos hasta que todos los pernos y tornillos estén listos para el ensamble. Para evitar daños a la rosca, NO sobre apriete los pernos y tornillos.

1. Desempacar la unidad y confirmar que se tiene todo el material de ferretería y partes requeridas. Ensamblar la unidad en un piso alfombrado o en el cartón vacío para evitar rasguños.
2. Orientar y adjuntar la repisa fija (B) al marco izquierdo (D) con 2 pernos de 35 mm (1), 2 arandelas de presión (2) y 2 arandelas planas (3). Apretar los pernos con la llave de trinquete provista.

## Instructivo de ensamble

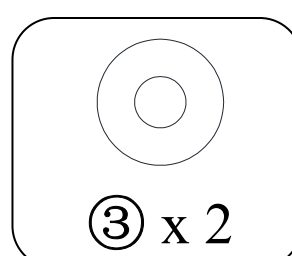
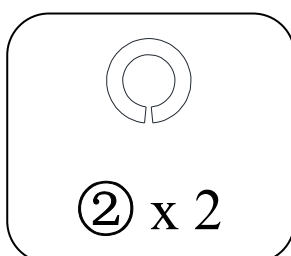
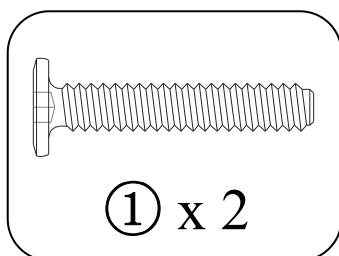
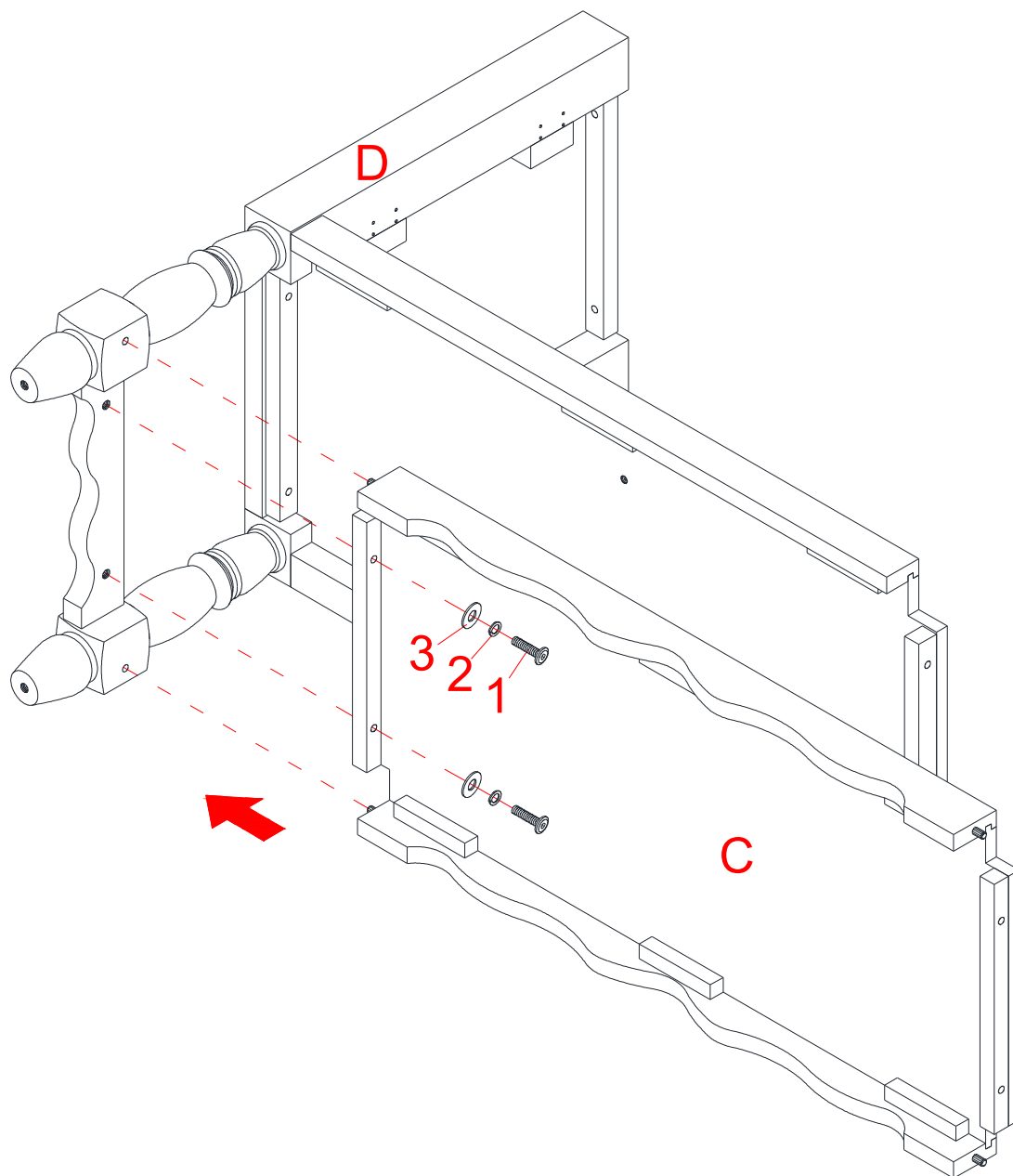

3. Usando las clavijas de madera como guía, alinear y adjuntar la repisa abierta (C) al marco izquierdo (D) con 2 pernos de 35 mm (1), 2 arandelas de presión (2) y 2 arandelas planas (3).

## Instructivo de ensamble

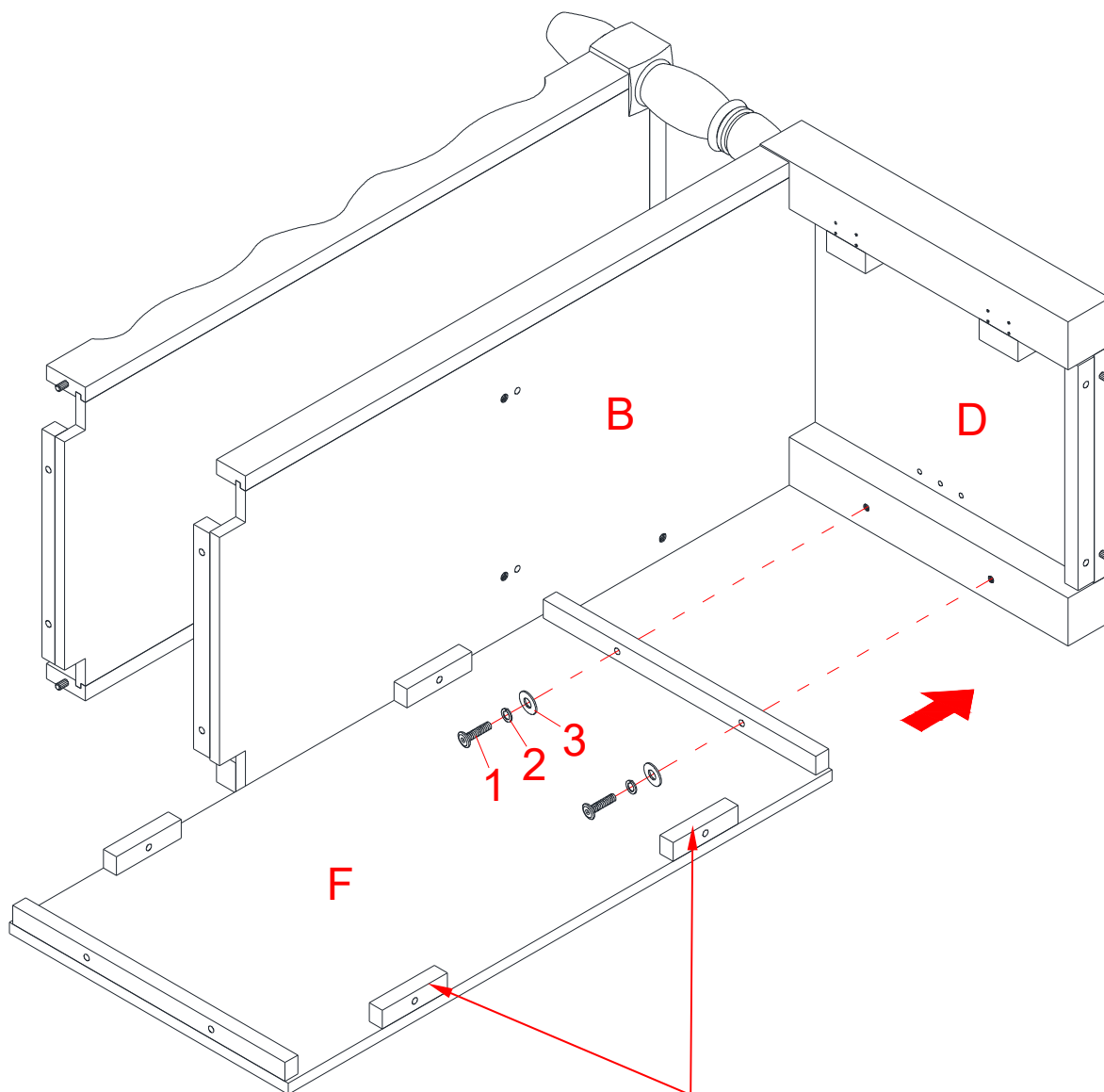

Los tacos apuntan hacia adentro

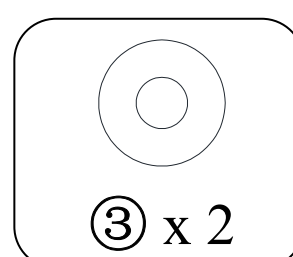
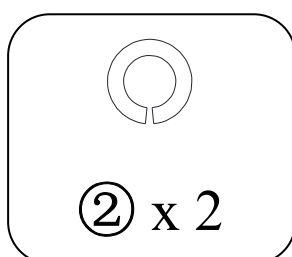
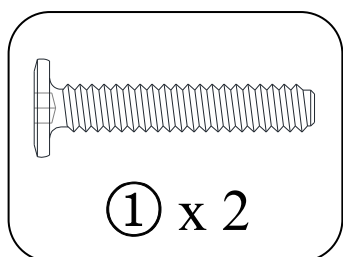

4. Orientar y adjuntar el panel posterior (F) al marco izquierdo (D) con 2 pernos de 35 mm (1), 2 arandelas de presión (2) y 2 arandelas planas (3).

## Instructivo de ensamble

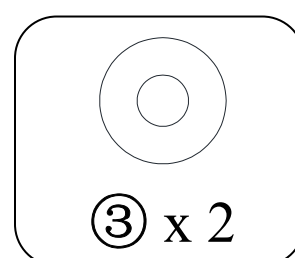
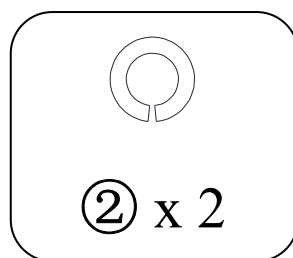
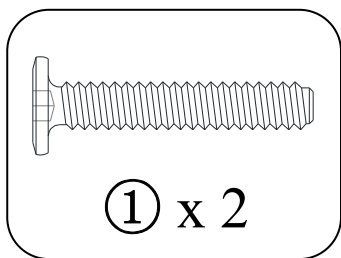
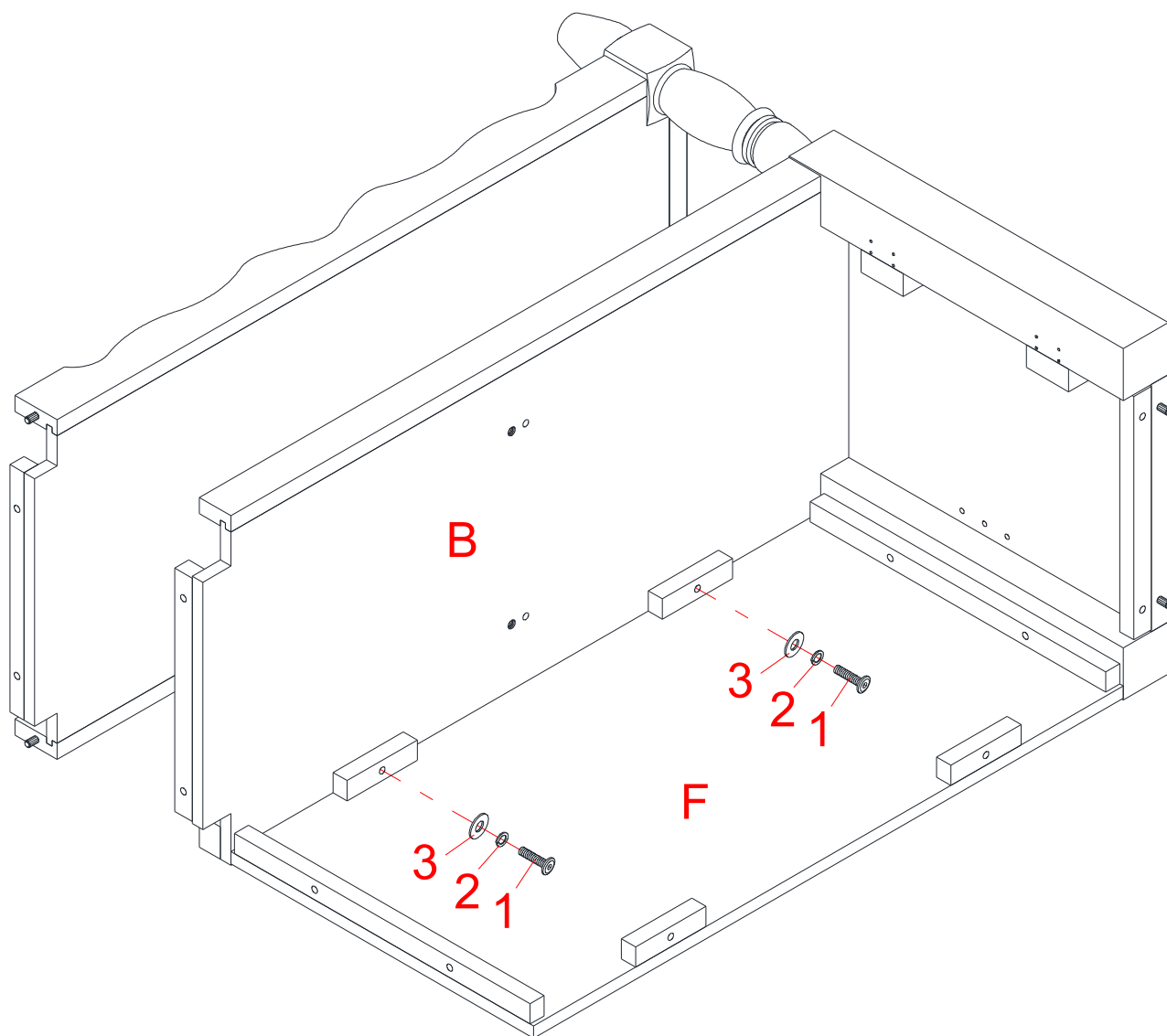

5. Insertar 2 pernos de 35 mm (1) con las arandelas (2 y 3) a través de los tacos en el panel posterior (F) y atornillar en los insertos roscados en la repisa fija (B).

## Instructivo de ensamble

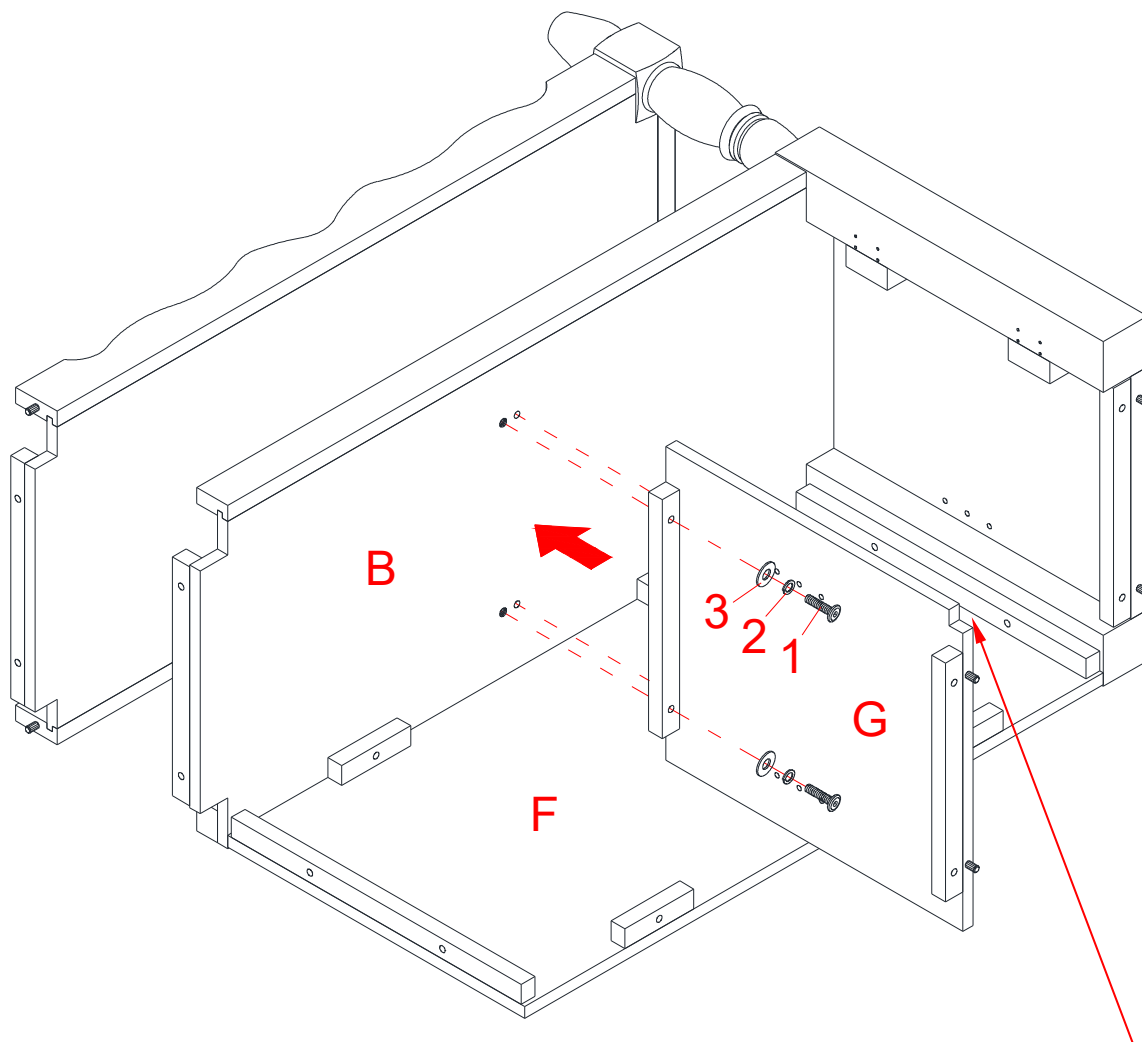

El espacio apunta hacia arriba

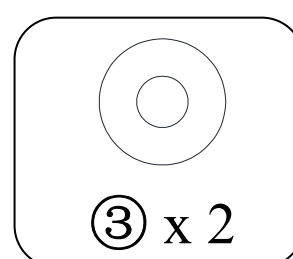
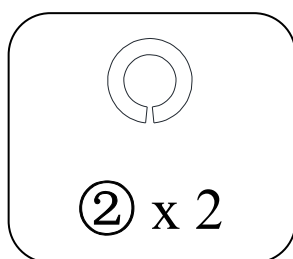
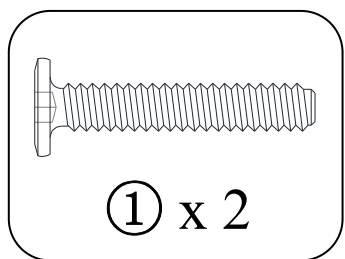

6. Orientar y adjuntar el panel divisor (G) a la repisa fija (B) con 2 pernos de 35 mm (1), 2 arandelas de presión (2) y 2 arandelas planas (3).

## Instructivo de ensamble

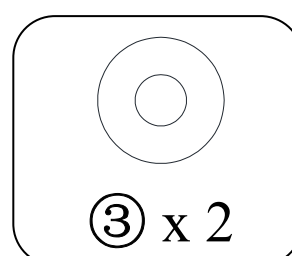
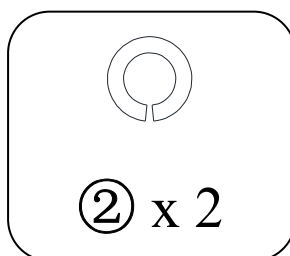
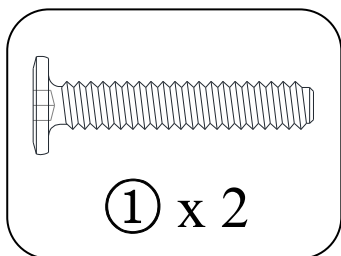
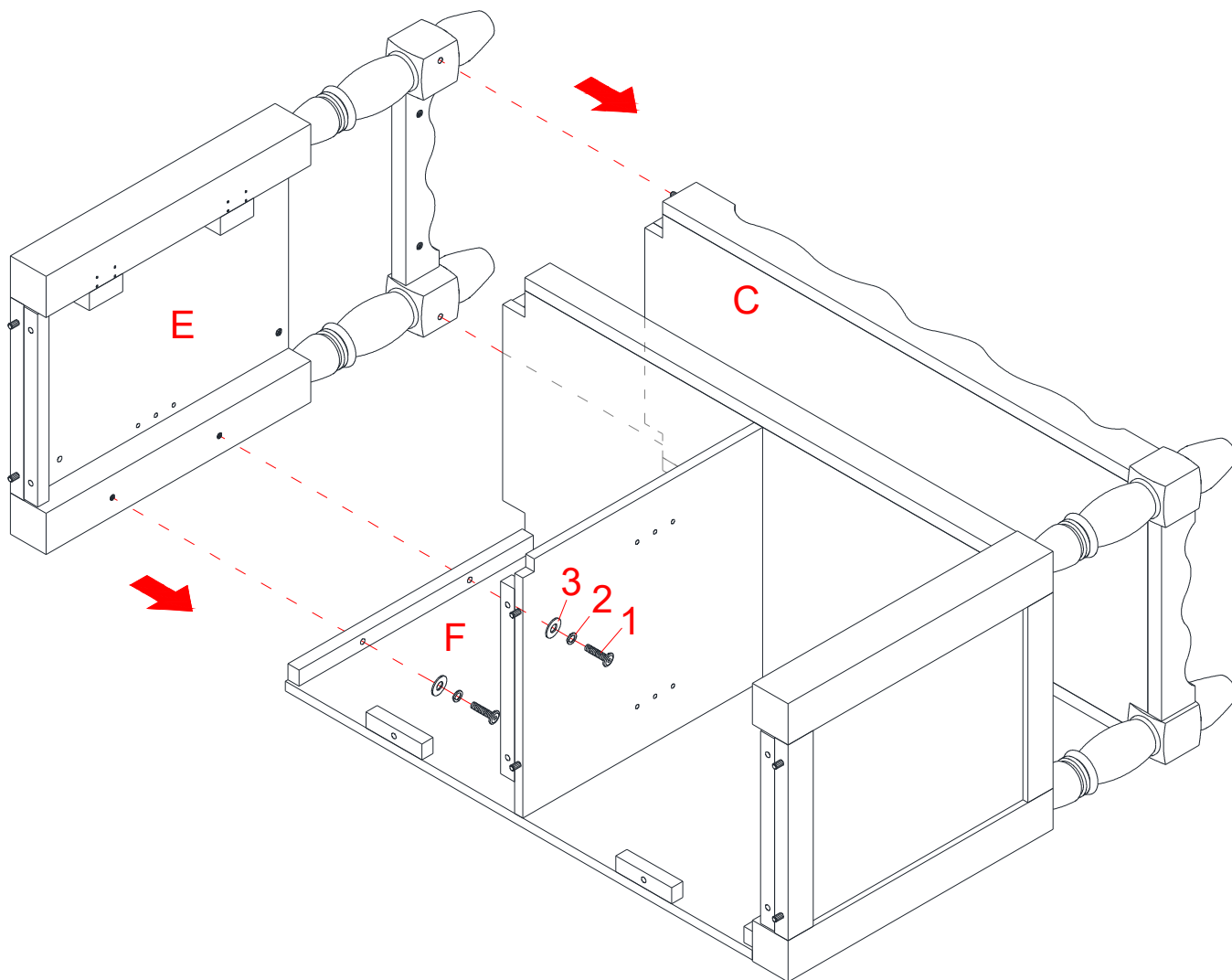

7. Usando las clavijas de madera como guía, alinear y adjuntar el marco derecho (E) al panel posterior ensamblado (F) con 2 pernos de 35 mm (1), 2 arandelas de presión (2) y 2 arandelas planas (3).

## Instructivo de ensamble

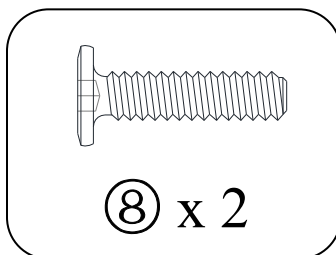
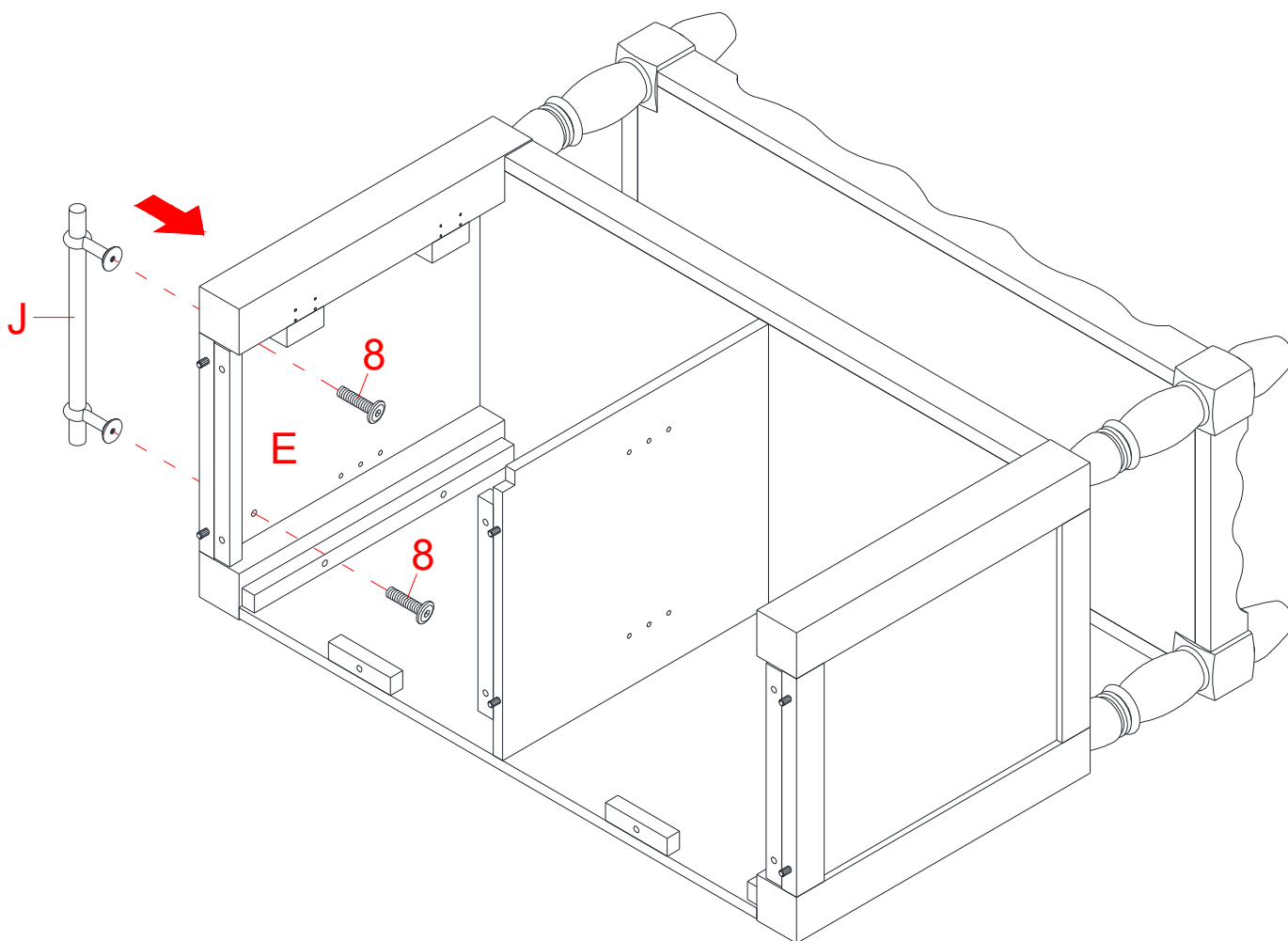

8. Adjuntar la manija lateral (J) al marco derecho (E) con 2 pernos de 25 mm (8).
9. Usted puede colgar sus telas o toallas en las manijas laterales (J) para accesos rápido.

## Instructivo de ensamble

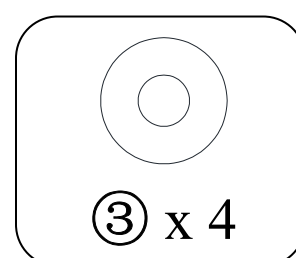
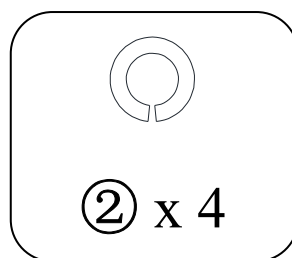
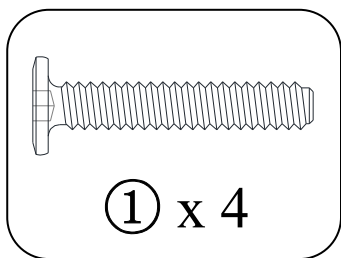
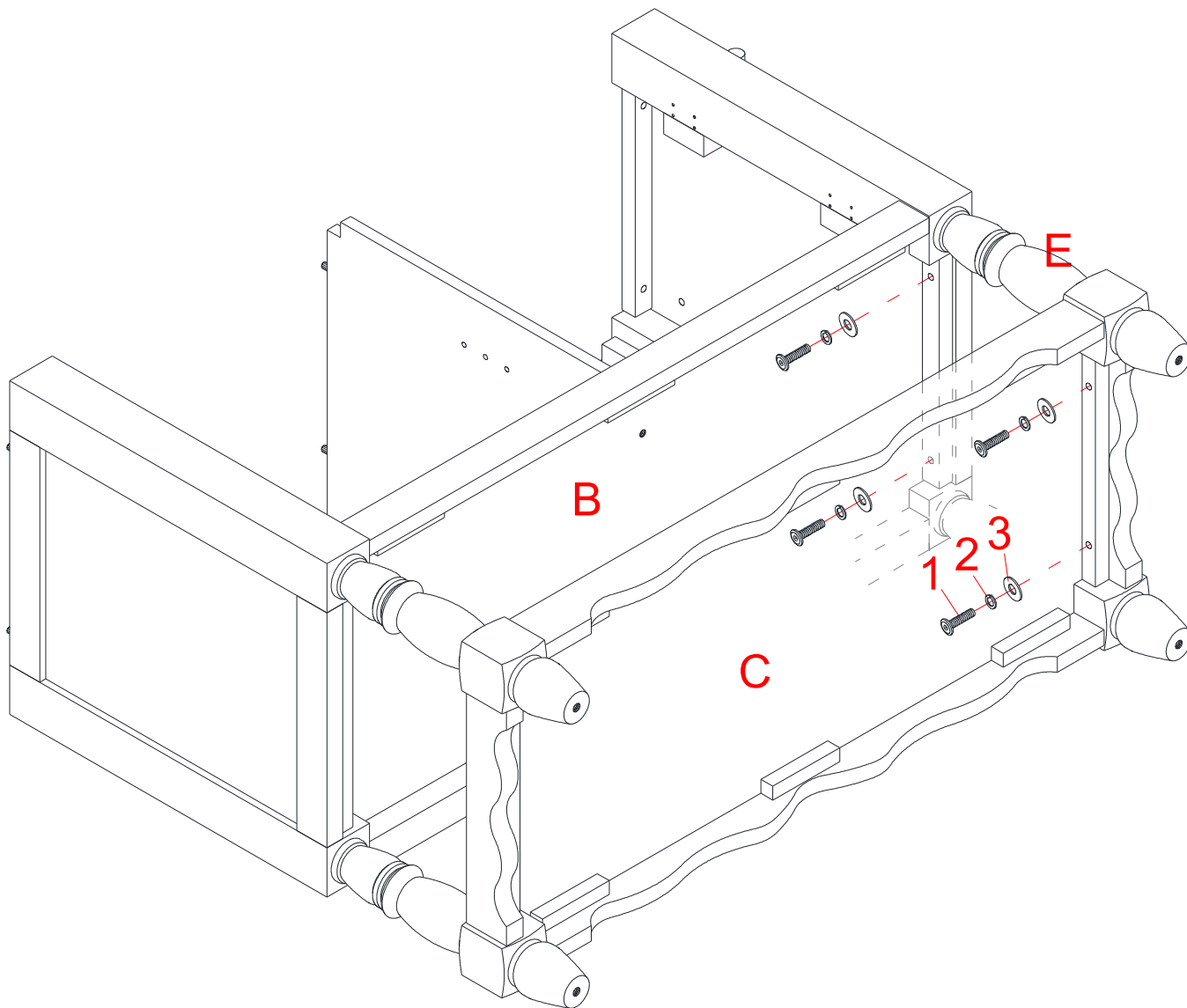

10. Asegurar el marco derecho (E) a ambas repisas fijas (B) y a la repisa abierta (C) con 4 pernos de 35 mm (1), 4 arandelas de presión (2) y 4 arandelas planas (3). **NO** apretar completamente los pernos.



## Instructivo de ensamble

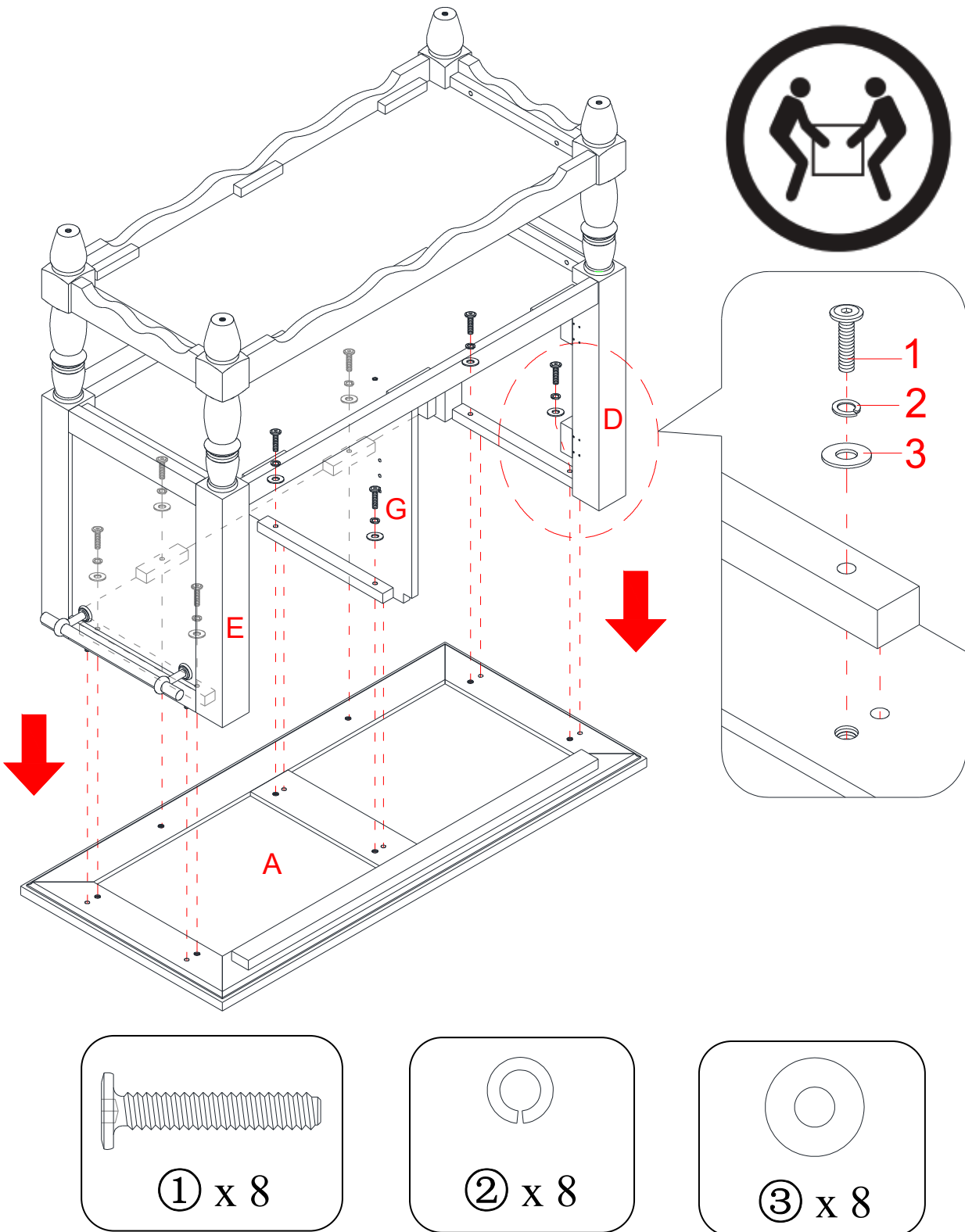

11. Descansar el panel superior (A) boca abajo en una superficie nivelada y protegida.

12. Usando las clavijas de madera como guía, alinear el ensamble previo al panel superior (A) apropiadamente y adjuntarlos en su lugar con 8 pernos de 35 mm (1), 8 arandelas de presión (2) y 8 arandelas planas (3). Apretar los pernos en su lugar con la llave de trinquete provista.

## Instructivo de ensamble

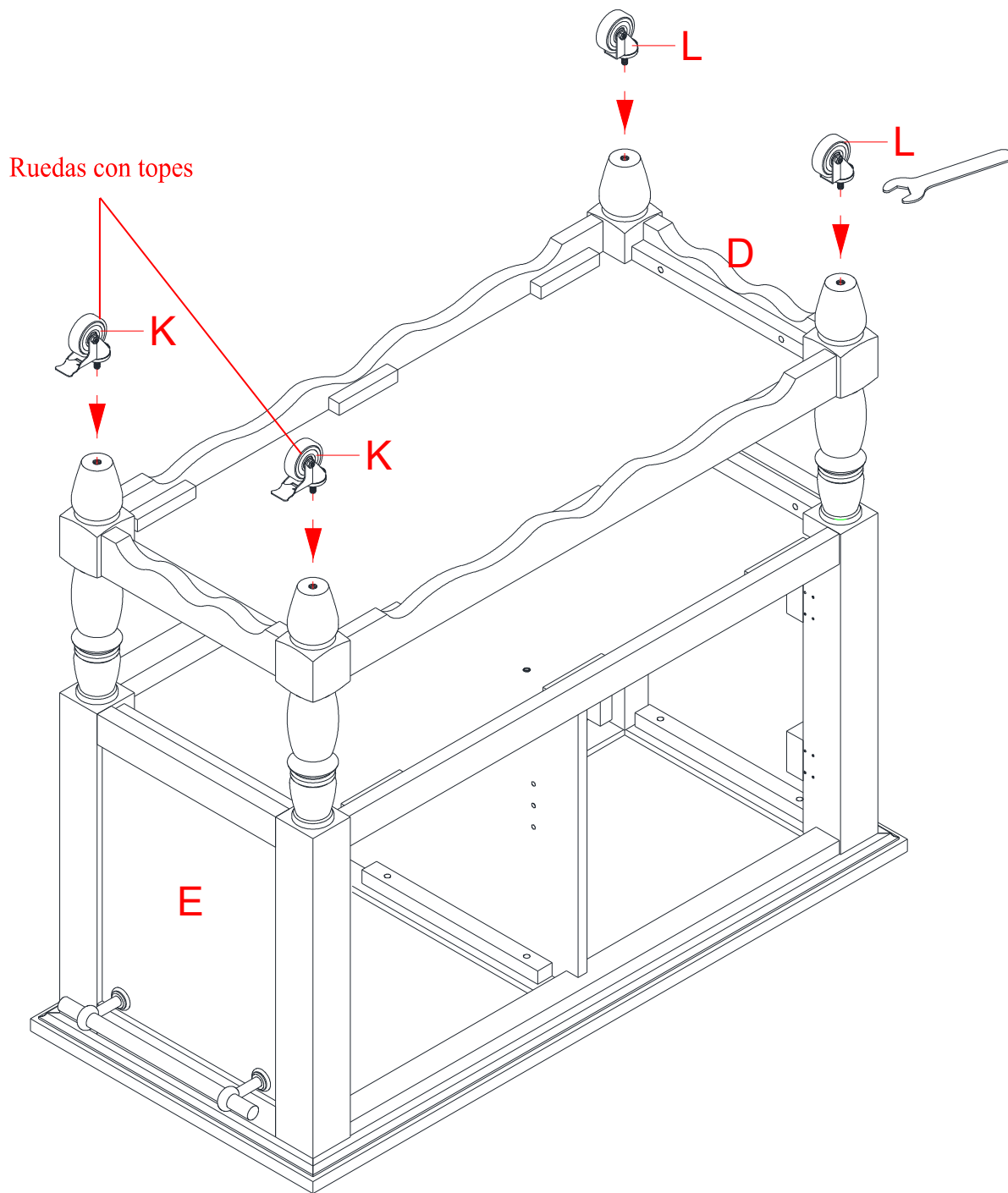

13. Sujetar las ruedas (K y L) a la parte inferior de ambos marcos laterales (D y E) usando la llave española provista. Asegurar de que las ruedas con tope (K) estén en el lado derecho.
14. Dos ruedas con tope (K) permiten que se pare el carrito cuando lo desee. Pise el freno para bloquear las ruedas (K) en su lugar para un uso seguro y estable.

## Instructivo de ensamble

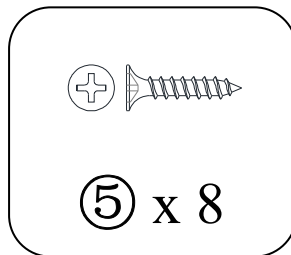
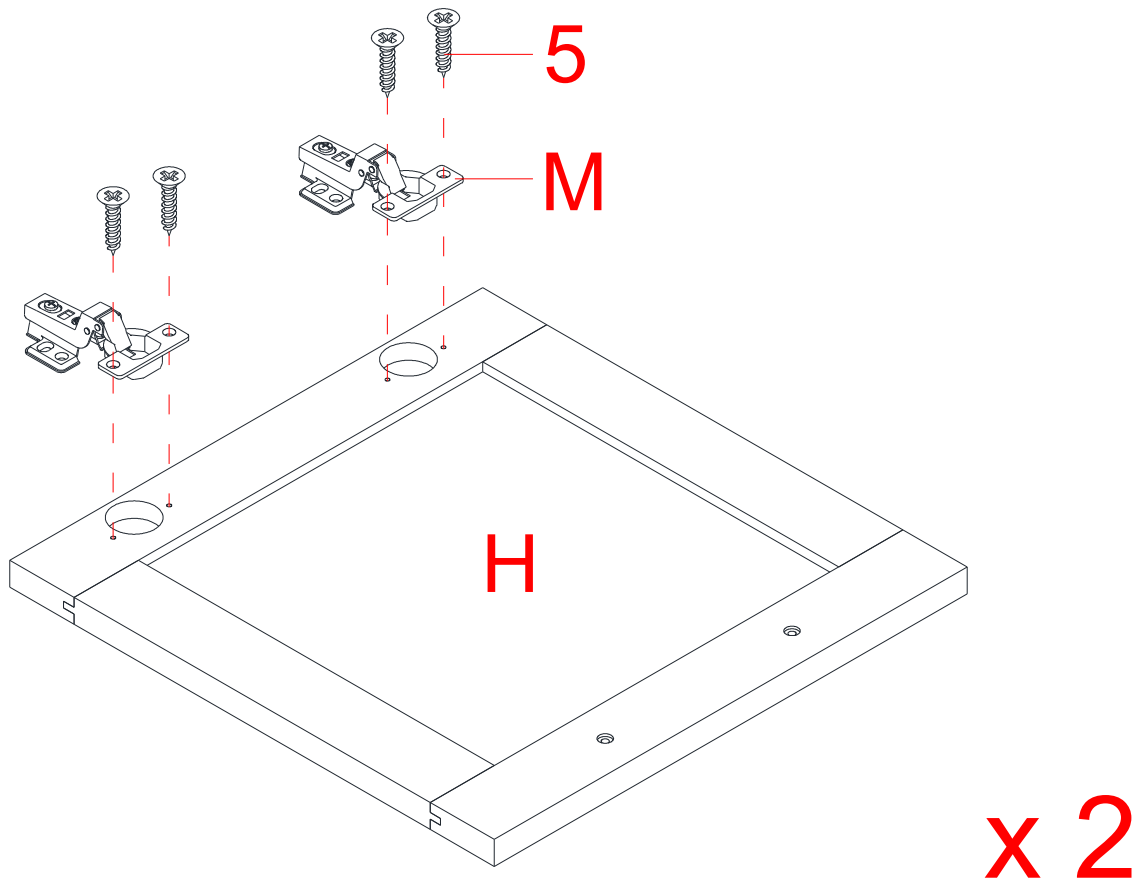

15. Extender 2 bisagras para puertas (M) y descansar las copas de las bisagras sobre los recortes de una puerta (H). Asegurar las bisagras para puertas (M) en su lugar usando 2 pernos de 15 mm (5) en cada una.
16. Completar esté paso 2 veces para ensamblar la otra puerta (H).

## Instructivo de ensamble

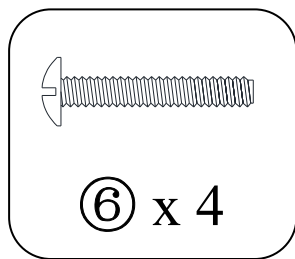
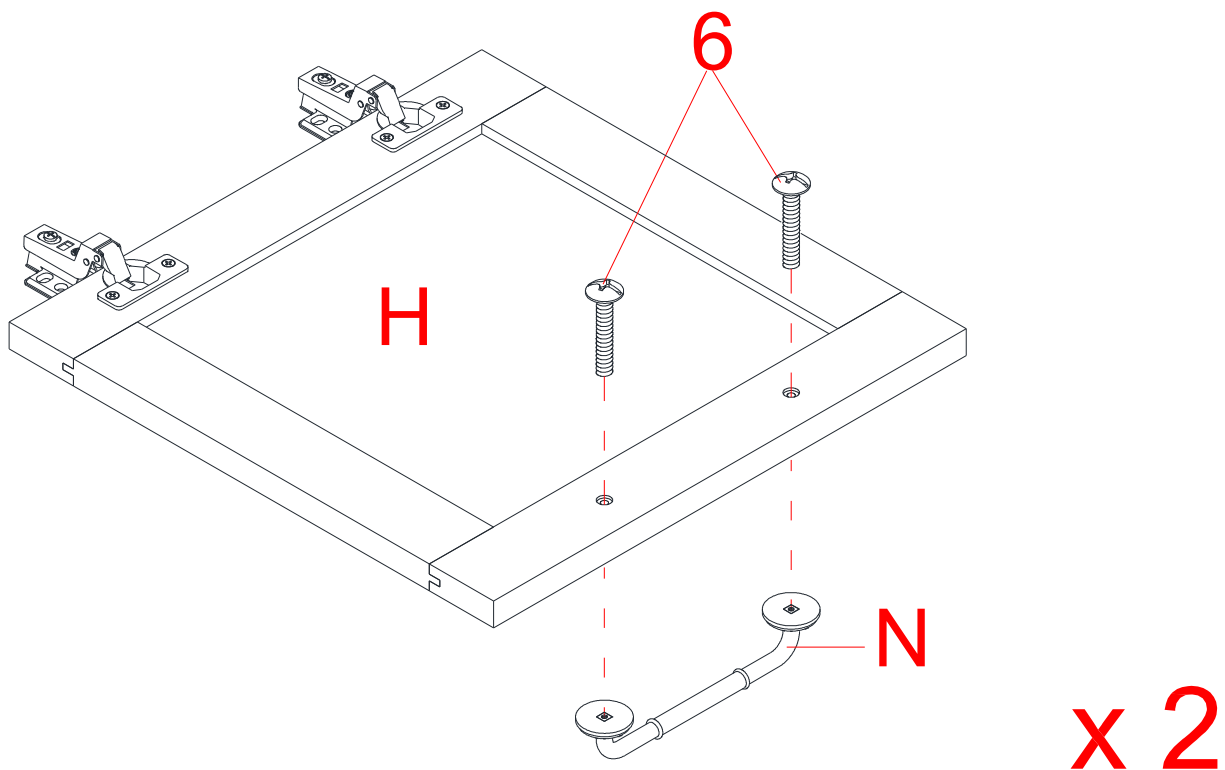

17. Adjuntar una manija para puerta (N) a lado exterior de cada puerta (H) con 2 pernos de 25 mm (6).

## Instructivo de ensamble

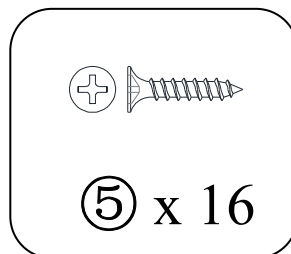
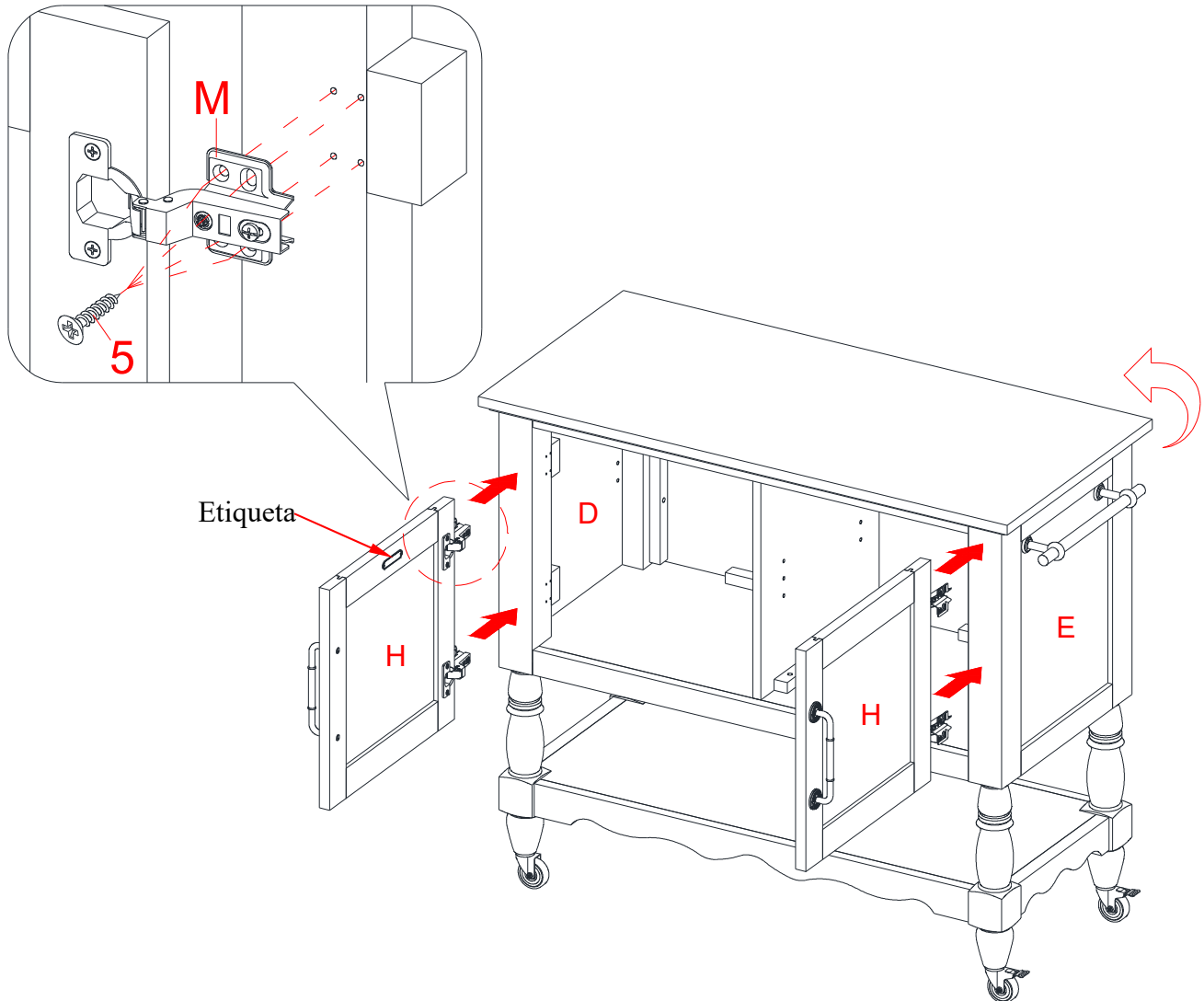

18. Pedir asistencia para poner la unidad ensamblada en posición vertical y cerca de la localización final.
19. Tomar una puerta (H) con la etiqueta y adjuntar las bisagras de la puerta extendidas (M) al marco izquierdo (D) con 8 pernos de 15 mm (5), usando los agujeros pilotos como guía. Asegurar de que ambas bisagras para puerta estén empleadas y funcionen apropiadamente.
20. Repetir el mismo procedimiento para adjuntar la otra puerta (H) al lado derecho (E).
21. Abrir y cerrar las puertas para asegurar de que estén alineadas y se cierren correctamente. Si fuera necesario, ajustar los pernos para un buen ajuste. Referirse a la etiqueta de la bisagra en el marco de la puerta para ajustar.

## Instructivo de ensamble

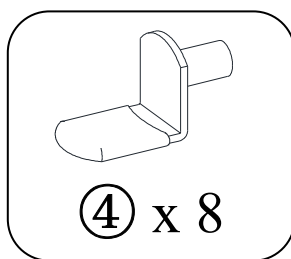
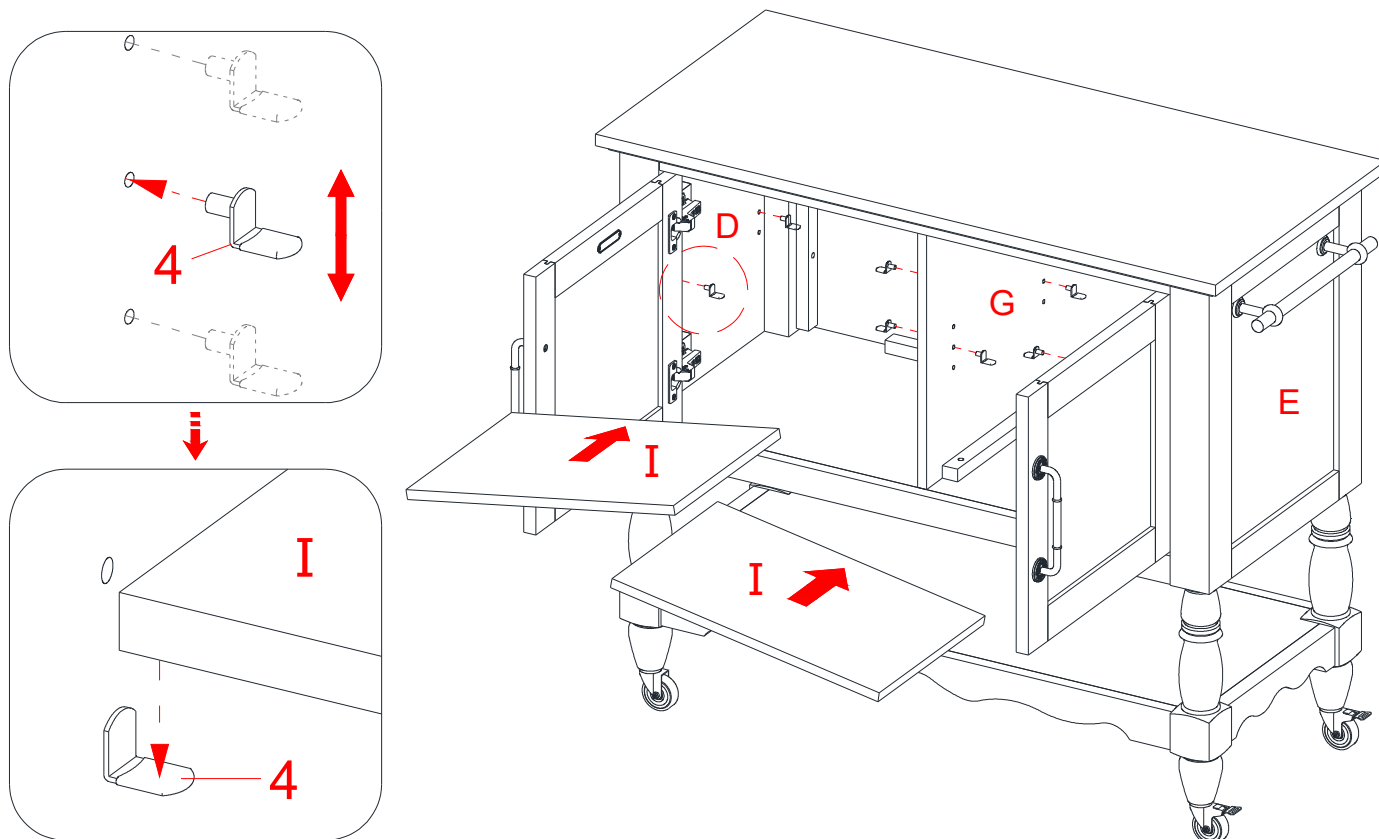

22. Insertar 4 soportes para repisa (4) en los agujeros a la altura deseada dentro de cada compartimiento. Asegurar de poner 4 soportes para repisa en el mismo nivel para nivelar la repisa.
23. Inclinarse y descansar las repisas ajustables (I) sobre los soportes para repisa (4).

## Instructivo de ensamble

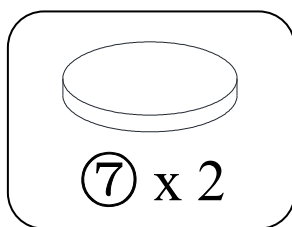
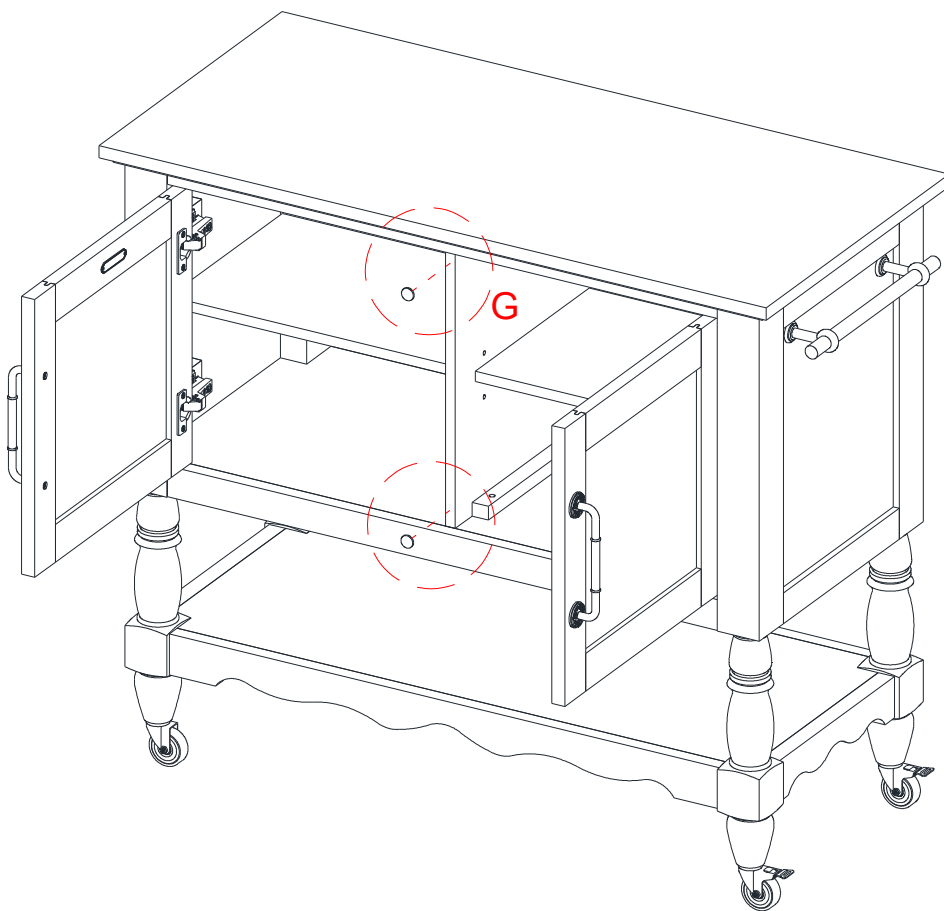
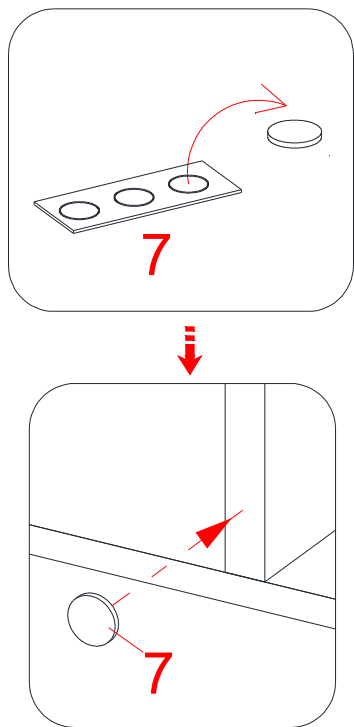

24. Despegar los toques de plástico (7) de la tarjeta de toques y pegarlos en el borde frontal del panel divisor (G) donde entran en contacto con las puertas (H).

## Mantenimiento y Cuidados

- Use una toalla suave y limpia para evitar daños y rayaduras.
- Uso de cera para pulir muebles no es necesario. Si desea usar cera, pruébela en un área que no sea visible para revisar su funcionamiento.
- Usar solventes de cualquier tipo puede dañar el acabado del mueble.
- Nunca use agua para limpiar la unidad, ya que le puede dañar el acabado.
- Siempre utilice protección para vasos cuando los ponga sobre la unidad.
- Líquidos derramados deben limpiarse inmediatamente, con una toalla suave evitando tallar.
- Siempre utilizar protectores en caso de poner cosas calientes. El calor puede provocar una reacción química en el acabado y dañarlo.
- Manchas o marcas de crayones o plumas de tinta serán difíciles de retirar.
- En caso de que su unidad sea manchada durante el uso le recomendamos hablar a un profesional para que le ayude.
- Revisar los pernos / tornillos periódicamente y apretar en caso necesario.

## Más recomendaciones para el cuidado de su mueble

Es mejor mantener la unidad en un área de clima controlado. Temperatura extrema y cambios de humedad pueden causar cambios como partes pandas, molduras que se contraigan o que la madera se raje. Es recomendable mantener la unidad lejos del sol directo ya que puede dañar el acabado.

Cuidados adecuados y limpieza pueden extender la vida útil de su unidad. Siga estas recomendaciones y mantendrá su mueble en buenas condiciones de uso por muchos años.

Un bolígrafo de retoque esta provisto para minimizar los golpes y rayaduras pequeñas que pueden ocurrir durante el ensamble o envío.

Esperamos que disfrute su mueble por muchos años.  
¡Gracias por su compra!

## GARANTÍA DE CALIDAD

Nosotros estamos seguros de que usted se encontrará feliz con la compra de este producto de Whalen Furniture.

Si este producto tiene algún defecto de ensamble o material, o si tiene alguna falla en uso normal, nosotros lo repararemos o lo re-emplazaremos hasta por un año a partir de la fecha de compra. Todo producto de Whalen Furniture es diseñado para alcanzar sus expectativas más altas. Nosotros le garantizamos que inmediatamente podrá ver el valor de nuestra mercancía de la más alta calidad.

Esta garantía le proporciona derechos legales específicos y tal vez tenga otros derechos que varían de estado a estado.

Whalen Furniture Manufacturing  
1578 Air Wing Road, San Diego, CA 92154, USA  
Servicio al cliente: 1-866-942-5362  
Hora estándar del Pacífico: 8:30 a.m. - 4:30 p.m., de lunes a viernes  
[www.whalenstyle.com](http://www.whalenstyle.com)