

Assembly Manual

Writing Desk

Model Number: SMWD-1-BR / SMWD-1-BR-E / SMWD-1-GR-E

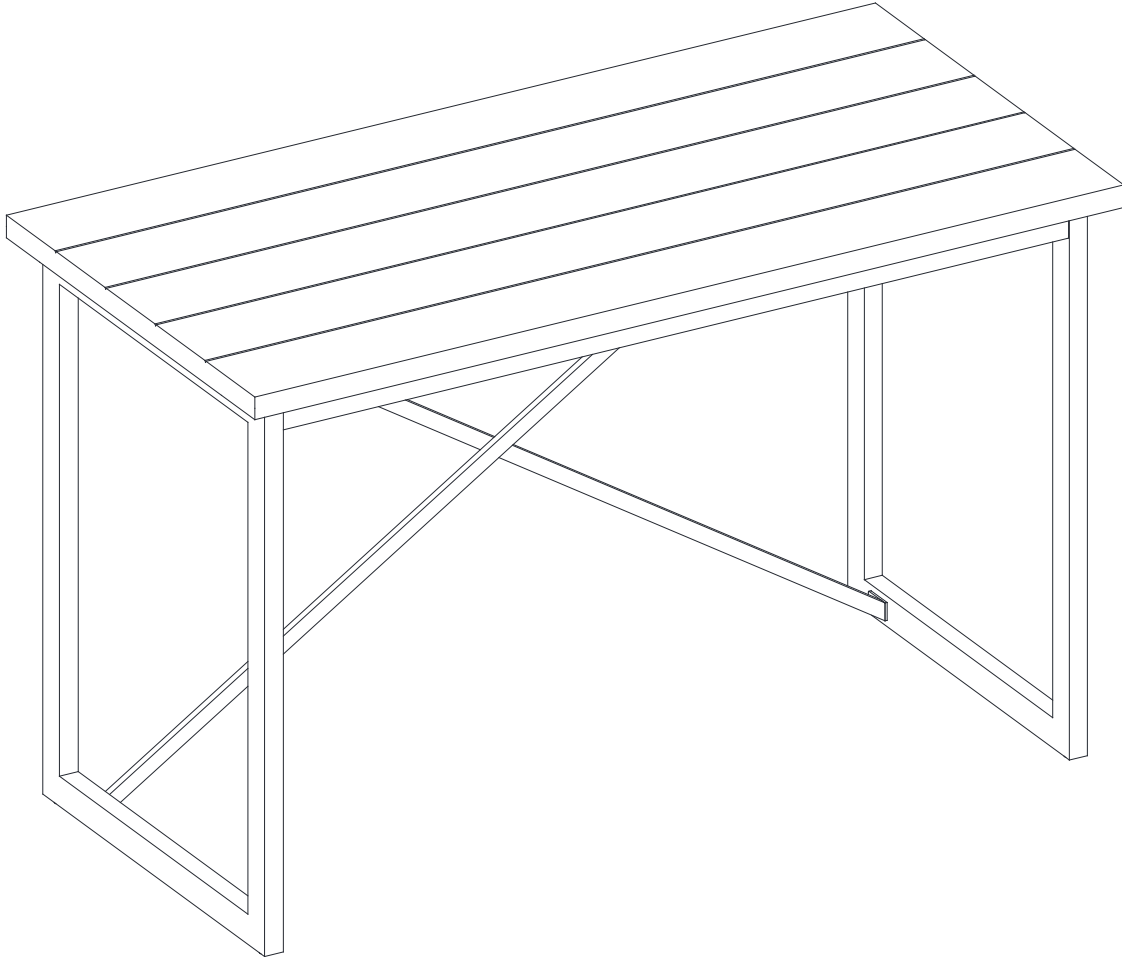

LOT NUMBER: _____ DATE PURCHASED: ____ / ____ / ____

**THIS ASSEMBLY MANUAL CONTAINS IMPORTANT SAFETY INFORMATION.
PLEASE READ AND KEEP FOR FUTURE REFERENCE.**

Questions or Comments?

We would love to hear about
your experience! Visit us at:
samsclub.com

Important Safety Information

- *Please read all instructions carefully before assembling this furniture.*
- *For your safety, assembly by two or more adults is strongly recommended.*
- *Use only vendor-supplied hardware to assemble this item. Using unauthorized hardware could jeopardize the structural integrity of the item.*
- *Hardware may loosen overtime. Periodically check that all connections are tight.*

Before Assembly

- *Remove all parts and hardware from the box. Place all items on a carpeted or scratch-free work surface, as this will avoid damaging parts during assembly.*
- *The shipping box provides an ideal work surface.*
- *To avoid accidentally discarding small parts or hardware, do not dispose of any packaging or contents of the shipping carton until assembly is complete.*
- *Use the parts and hardware lists below to identify and separate each of the pieces included.*
- *The use of power tools for assembly is not recommended. Power tools can damage the hardware and/or split the wood.*
- **Note:** *Do not fully tighten all bolts until all parts are in place. Failure to follow these instructions may cause the bolts to misalign during assembly.*

Care and Cleaning

- *Use a soft, clean cloth that will not scratch the surface when dusting.*
- *Use of furniture polish is not necessary. Should you choose to use polish, test first in an inconspicuous area.*
- *Using solvents of any kind on your furniture may damage the finish.*
- *Never use water to clean your furniture as it may cause damage to the finish.*
- *Liquid spills should be removed immediately. Using a soft clean cloth, blot the spill gently. Avoid rubbing.*
- *Do not place furniture in direct sunlight.*

Maximum Recommended Weight Loads

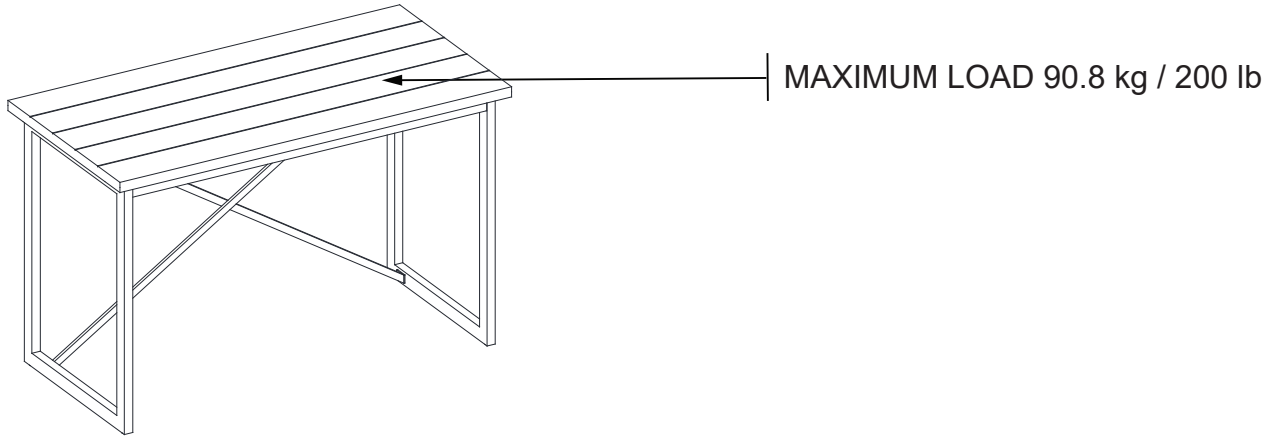



⚠ WARNING THIS UNIT IS INTENDED ONLY FOR USE WITHIN THE MAXIMUM WEIGHTS INDICATED. USE WITH LOAD HEAVIER THAN THE MAXIMUM WEIGHTS INDICATED MAY RESULT IN INSTABILITY, CAUSING POSSIBLE INJURY

Components

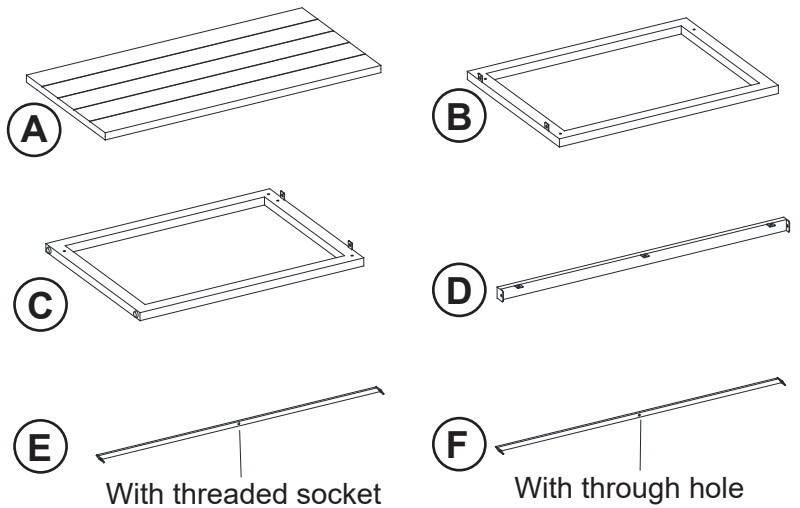

- A.....Top Panel1
- B.....Left Side Frame.....1
- C.....Right Side Frame.....1
- D.....Stretcher.....2
- E.....Front Metal Bar.....1
- F.....Back Metal Bar.....1

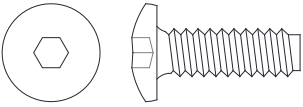

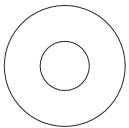
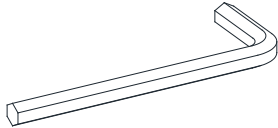
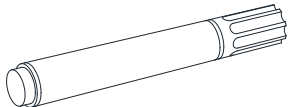
Hardware

<p>(H1) 1/4" x 19 mm Bolt Qty: 19+1 extra</p> 	<p>(H2) Lock Washer Qty: 19+1 extra</p> 	<p>(H3) Flat Washer Qty: 19+1 extra</p> 
<p>(H4) Hex Wrench Qty: 1</p> 	<p>(H5) Touch-up Pen Qty: 1</p> 	

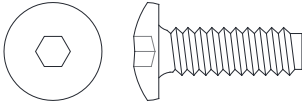
Step 1

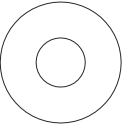
<p>(H1) 1/4" x 19 mm Bolt Qty: 6</p> 	<p>(H2) Lock Washer Qty: 6</p> 	<p>(H3) Flat Washer Qty: 6</p> 
---	--	---

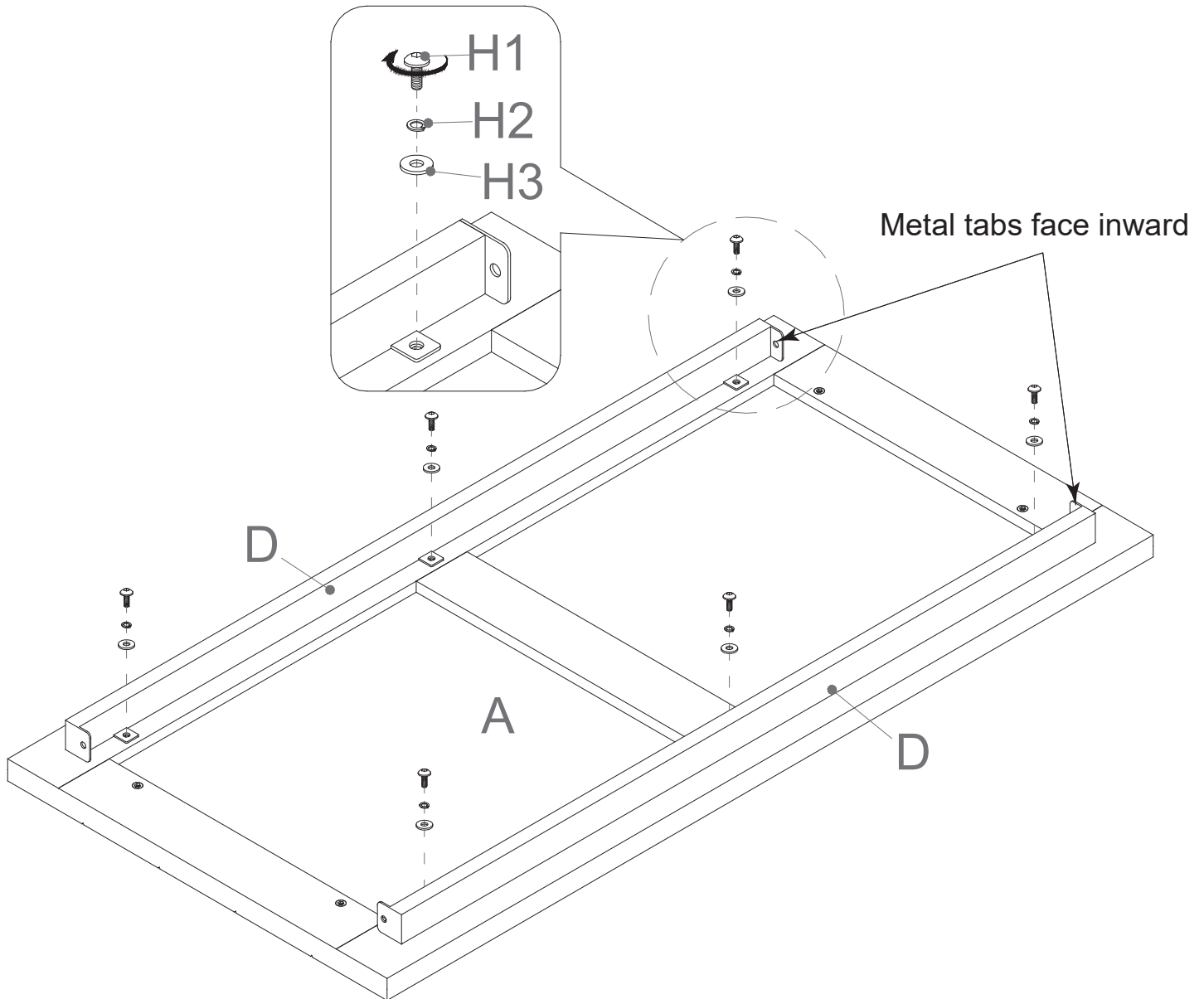



NOTE: Please do not fully tighten all bolts until you finish assembling all parts. Once assembled, go back and fully tighten all bolts. This will make the assembly easier

Unpack the unit and confirm that you have all the hardware and required parts listed. Assemble the unit on a carpeted floor or the empty carton to avoid any scratch.

Align and attach the Stretchers (D) to the Top Panel (A) with six 19 mm Bolts (H1) and the Washers (H2 and H3). Tighten the bolts with the provided hex wrench.

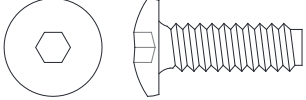
Step 2

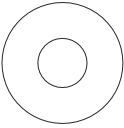
<p>(H1) 1/4" x 19 mm Bolt Qty: 8</p> 	<p>(H2) Lock Washer Qty: 8</p> 	<p>(H3) Flat Washer Qty: 8</p> 
---	--	---

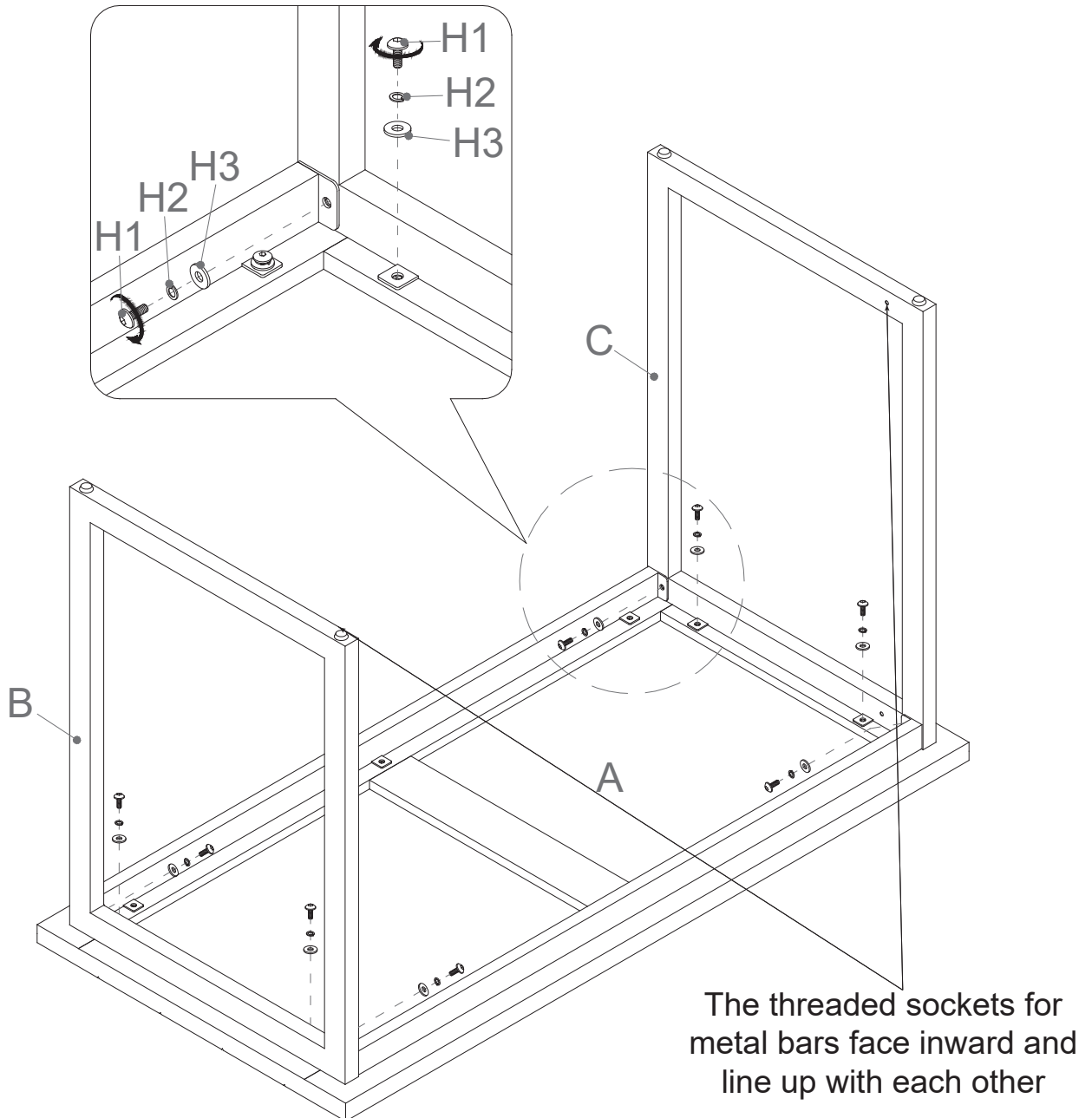

Align and attach the Side Frames (B and C) to the Top Panel (A) with four 19 mm Bolts (H1) and the Washers (H2 and H3).

Proceed to fasten the Side Frames (B and C) to the Stretchers (D) with four 19 mm Bolts (H1) and the Washers (H2 and H3).

Step 3

(H1)
1/4" x 19 mm Bolt
Qty: 2

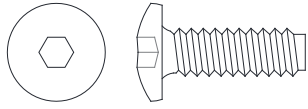

(H2)
Lock Washer
Qty: 2



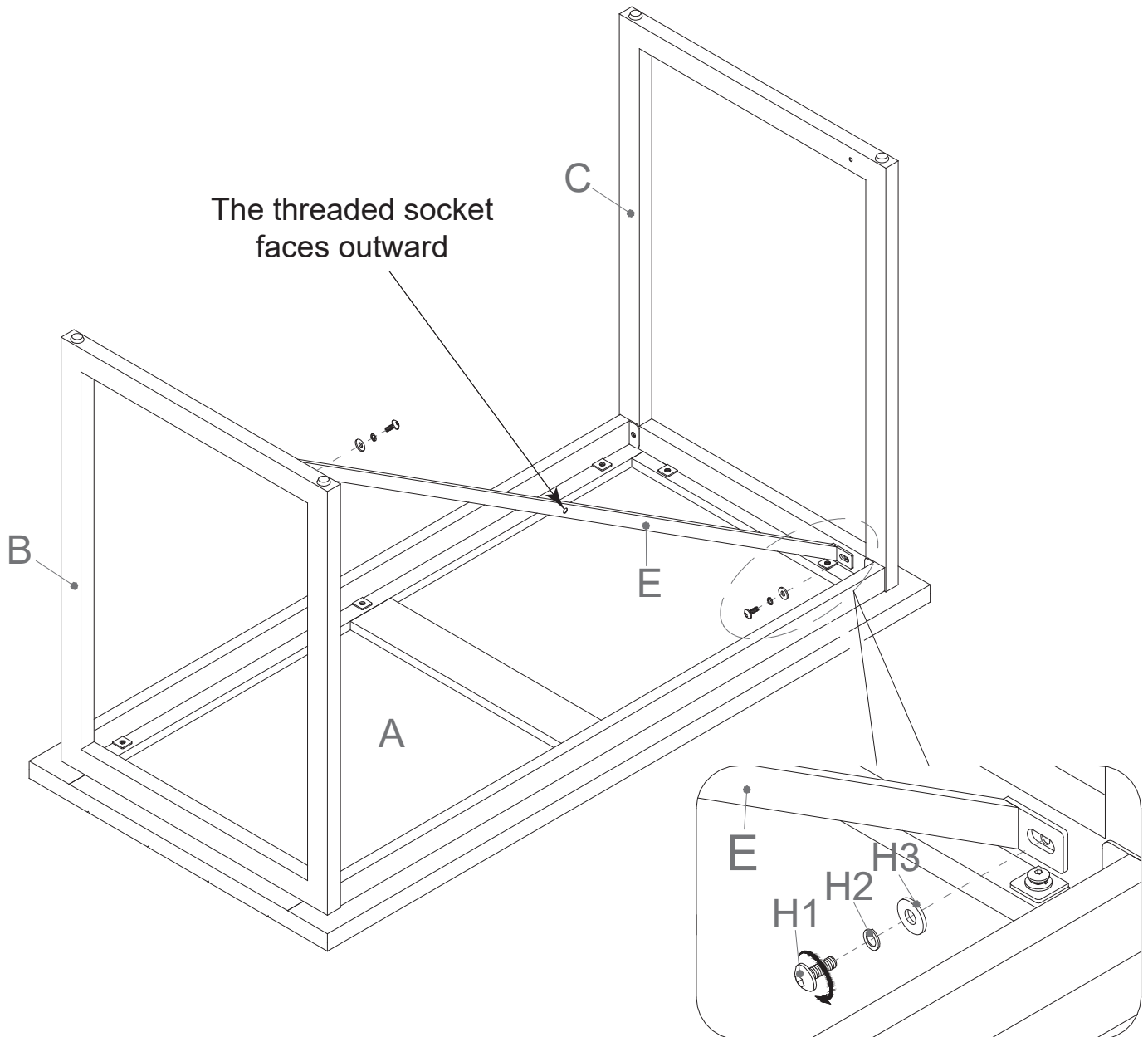
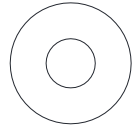

(H3)
Flat Washer
Qty: 2

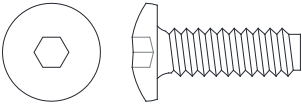

Align and attach the Front Metal Bar (E) between the Side Frames (B and C) with two 19 mm Bolts (H1) and the Washers (H2 and H3). DO NOT fasten the bolts.

Step 4

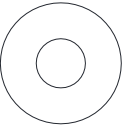
<p>(H1) 1/4" x 19 mm Bolt Qty: 3</p> 	<p>(H2) Lock Washer Qty: 3</p> 	<p>(H3) Flat Washer Qty: 3</p> 
---	--	---

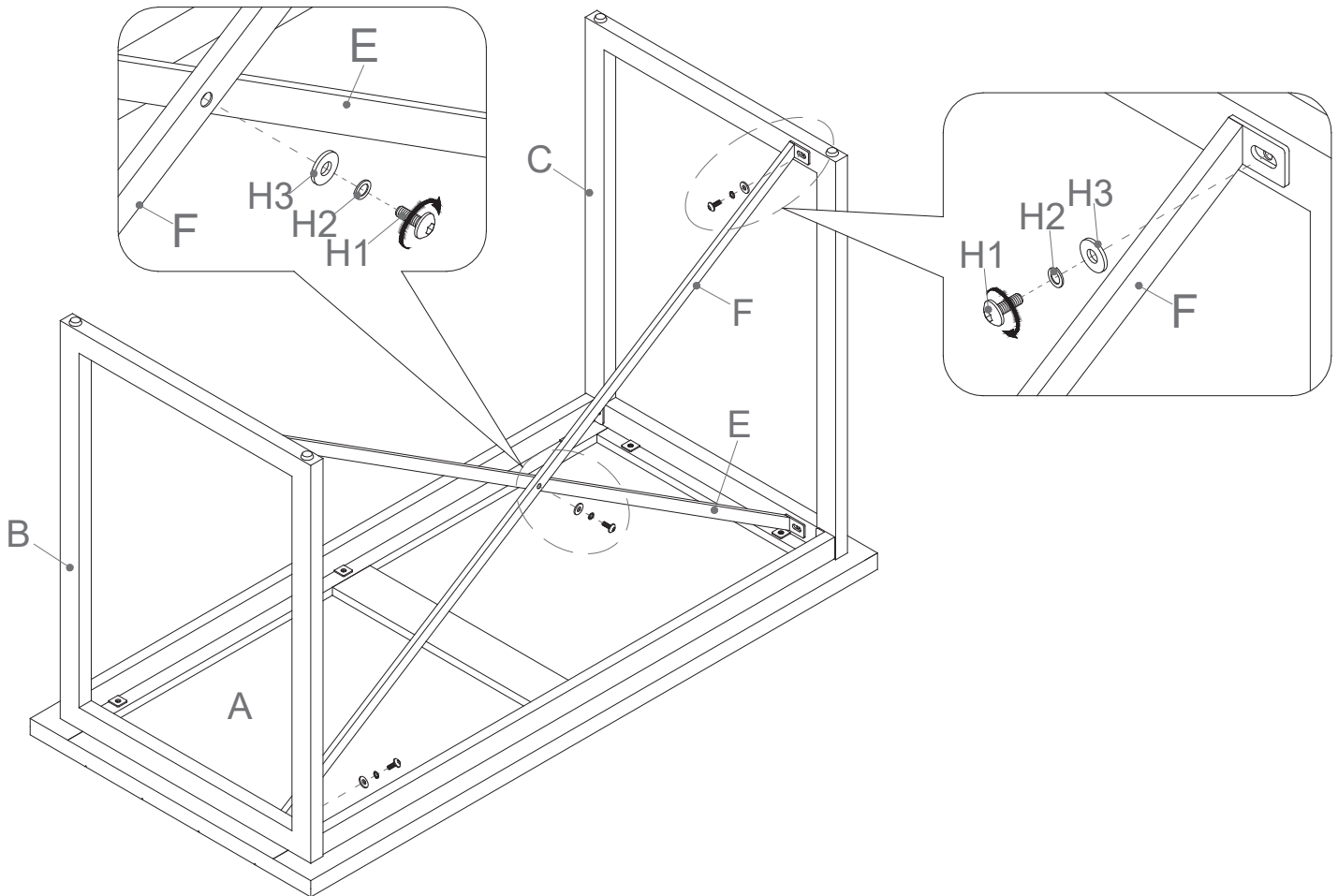

Repeat the previous step to attach the Back Metal Bar (F) to the Side Frames (B and C). Proceed to fasten the Back Metal Bar (F) to the Front Metal Bar (E) with one 19 mm Bolt (H1) and the Washers (H2 and H3).

Now, go back and securely tighten all the bolts. Make sure that all the parts are tight and there are no gaps between the parts. This will help keep the unit square.

Step 5

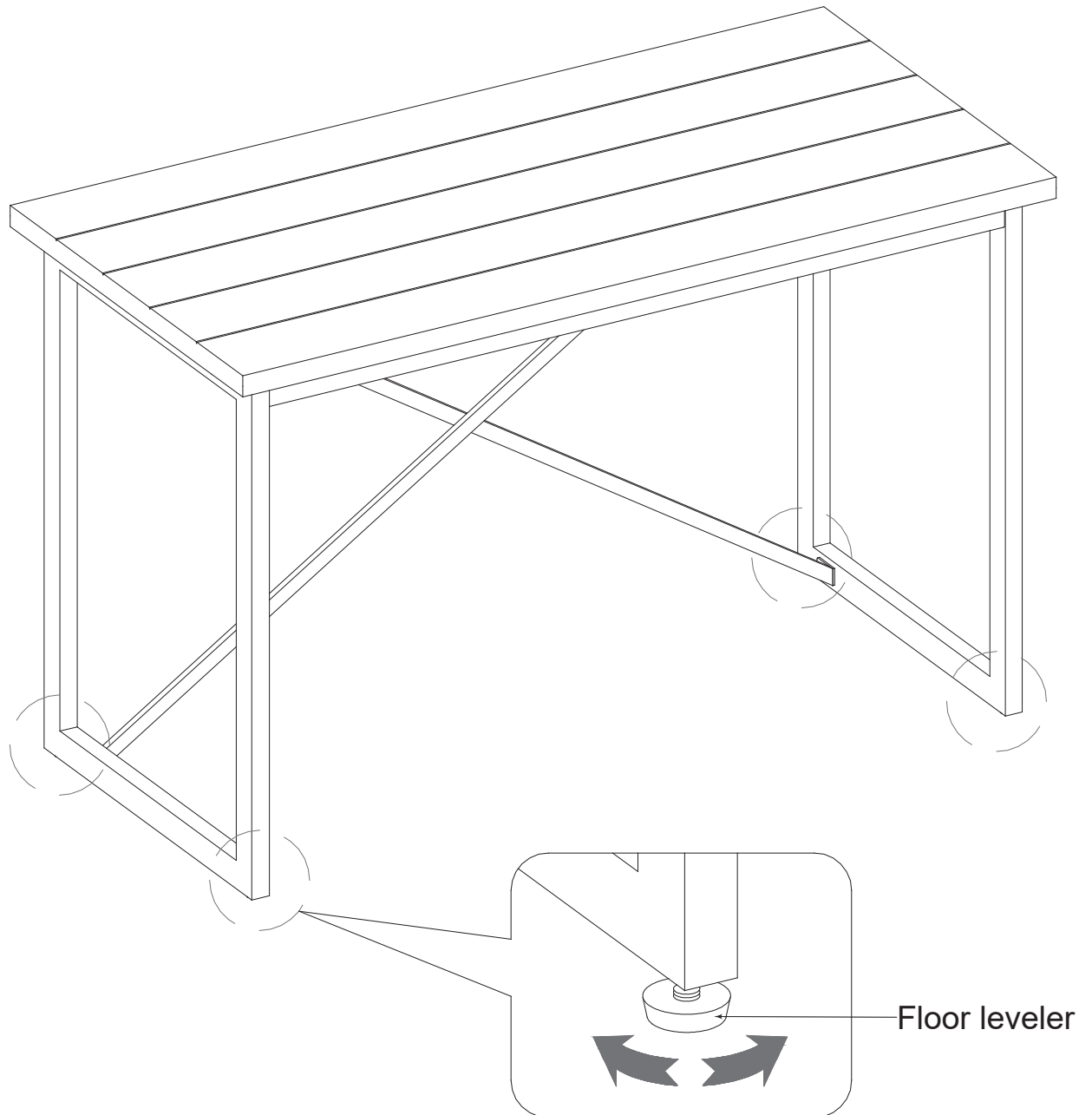

Ask for assistance to lift the assembled unit upright and position it at the desired location. If necessary, adjust the pre-attached floor levelers to correct tilting.

Manual de ensamble

Escritorio

Número de modelo: SMWD-1-BR / SMWD-1-BR-E / SMWD-1-GR-E

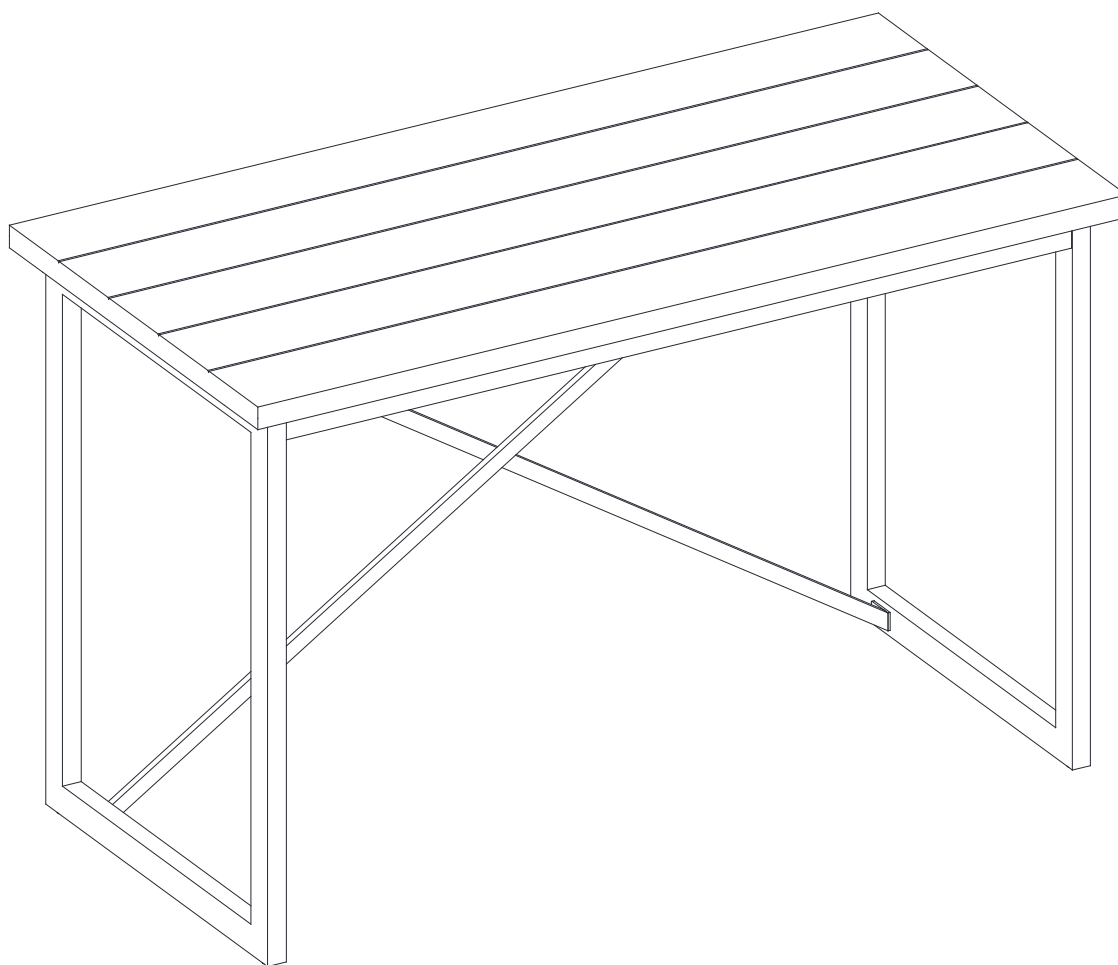

NÚMERO de LOTE: _____ FECHA de COMPRA: ____ / ____ / ____

ESTÉ MANUAL DE ENSAMBLE CONTIENE INFORMACIÓN DE SEGURIDAD IMPORTANTE. POR FAVOR LEA Y MANTENGA PARA REFERENCIA FUTURA.

¿Preguntas o Comentarios?

¡Nos gustaría escuchar sobre su experiencia! Visitenos en: samsclub.com

Información de seguridad importante

- *Por favor lea todas las instrucciones antes de ensamblar el mueble.*
- *Por su seguridad, se recomienda ensamblar con dos o más adultos.*
- *Use solo ferretería suplida por el vendedor para ensamblar la unidad. El uso de ferretería no autorizada podría poner en riesgo la integridad estructural de la unidad.*
- *La ferretería se podría aflojar con el tiempo. Revisar periódicamente que las conexiones estén apretadas.*

Antes de ensamblar

- *Retirar todas las partes y ferretería de la caja. Poner todo sobre una alfombra o en un are libre de rasguños, para evitar danos a las partes durante el ensamble.*
- *La caja de envío provee una superficie ideal de trabajo.*
- *Para evitar el desecho accidental de partes o ferretería pequeñas, no tire ningún paquete o contenidos del paquete hasta terminar el ensamble.*
- *Usar las listas de partes y ferretería para identificar y separar cada una de las piezas incluidas.*
- *El uso de herramientas eléctricas no está recomendado. Estas herramientas pueden dañar la ferretería o la madera.*
- **Nota:** *No apretar completamente los pernos hasta que las partes estén en su lugar. La falla de seguir estas instrucciones puede causar que los pernos se desalineen durante el ensamble.*

Mantenimiento y limpieza

- *Use una toalla suave y limpia que no rayara la superficie al limpiar.*
- *Uso de cera para pulir muebles no es necesario. Si desea usar cera, pruébela en un área que no sea visible para revisar su funcionamiento.*
- *Usar solventes de cualquier tipo puede dañar el acabado del mueble.*
- *Nunca use agua para limpiar la unidad, ya que le puede dañar el acabado.*
- *Líquidos derramados deben limpiarse inmediatamente, con una toalla suave evitando tallar.*
- *No poner el mueble en luz solar directa.*

Pesos máximos recomendados

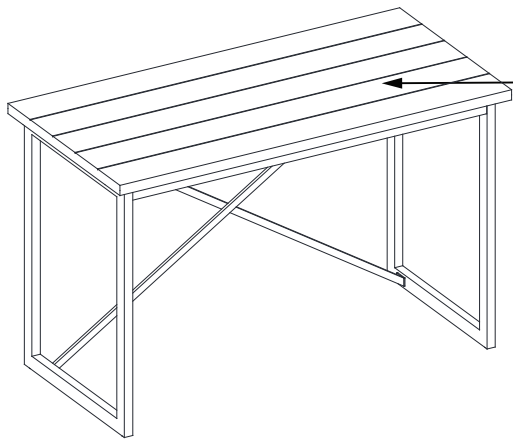

CARGA MÁXIMA 90.8 kg / 200 lb



⚠ ADVERTENCIA ESTA UNIDAD DEBE UTILIZARSE CON LOS PESOS MÁXIMOS INDICADOS. SI SE EXCEDE EL PESO MÁXIMO, PODRÍA RESULTAR EN UNA INESTABILIDAD DE LA UNIDAD CAUSANDO POSIBLES LESIONES.

Componentes

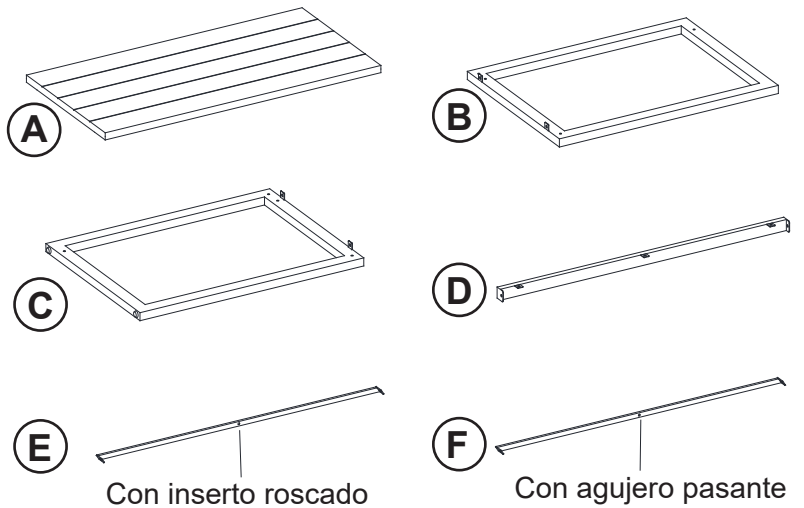

- A.....Panel superior.....1
- B.....Marco izquierdo.....1
- C.....Marco derecho.....1
- D.....Soporte.....2
- E.....Barra de metal frontal...1
- F.....Barra de metal posterior..1

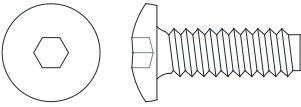

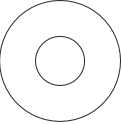
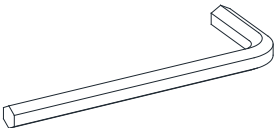
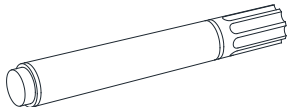
Material de ferretería

<p>(H1) Perno de 1/4" x 19 mm Cant: 19+1 extra</p> 	<p>(H2) Arandela de presión Cant: 19+1 extra</p> 	<p>(H3) Arandela plana Cant: 19+1 extra</p> 
<p>(H4) Llave hexagonal Cant: 1</p> 	<p>(H5) Plumón Cant: 1</p> 	

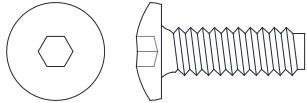
Paso 1

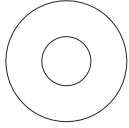
(H1) Perno de 1/4" x 19 mm Cant: 6		(H2) Arandela de presión Cant: 6		(H3) Arandela plana Cant: 6	
--	---	--	--	---	---

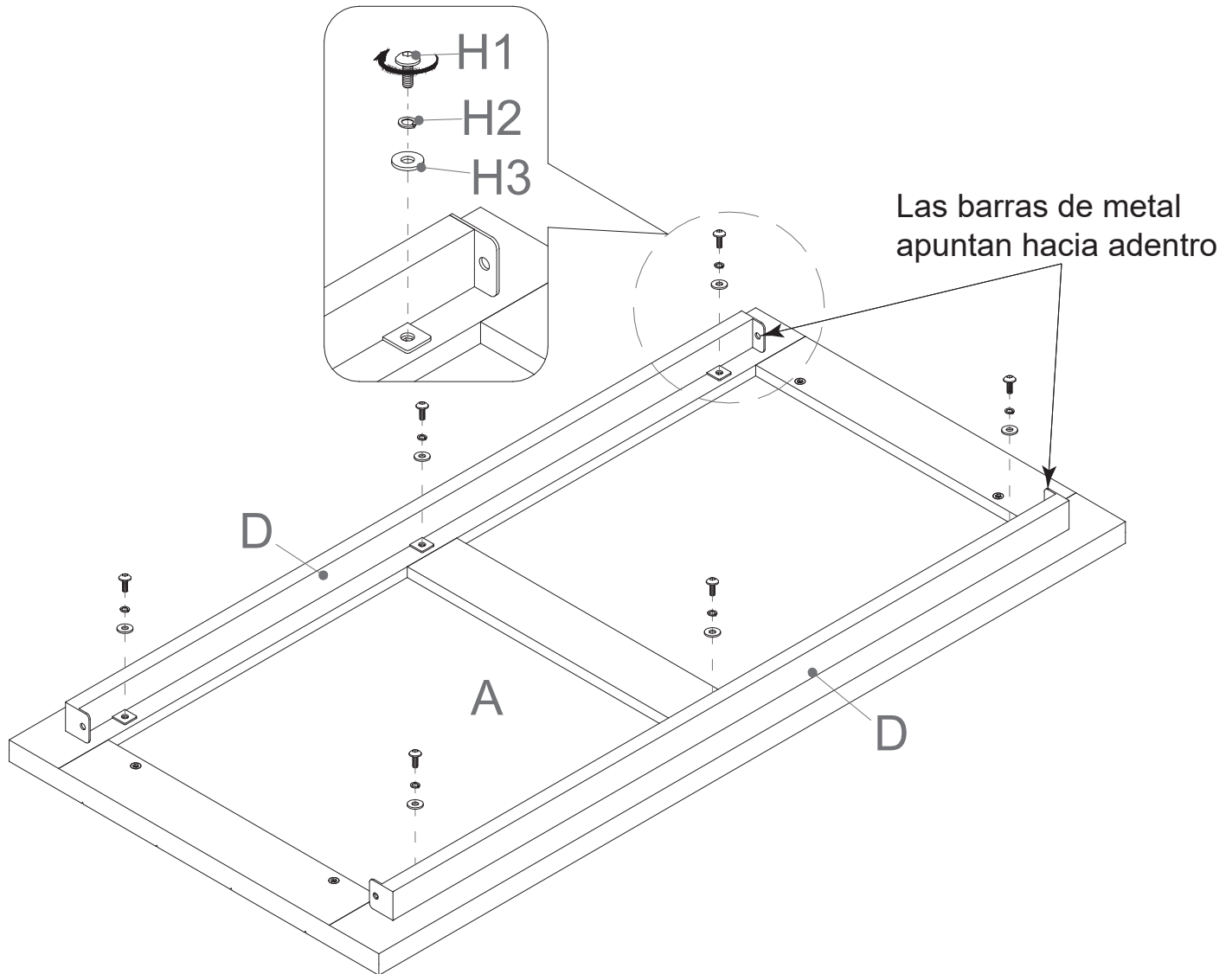

NOTA: Por favor no apriete completamente todos los pernos, hasta que termine con el ensamble de las partes, después asegúrese de apretar todos los pernos, esto hará el ensamble más fácil.

Desempacar la unidad y confirmar que se tiene todo el material de ferretería y partes requeridas. Ensamblar la unidad en un piso alfombrado o en el cartón vacío para evitar rasguños.

Alinear y adjuntar los soportes (D) al panel superior (A) con 6 pernos de 19 mm (H1) y sus arandelas (H2 y H3). Apretar los pernos con la llave hexagonal provista.

Paso 2

(H1) Perno de 1/4" x 19 mm Cant: 8	(H2) Arandela de presión Cant: 8	(H3) Arandela plana Cant: 8
--	--	---

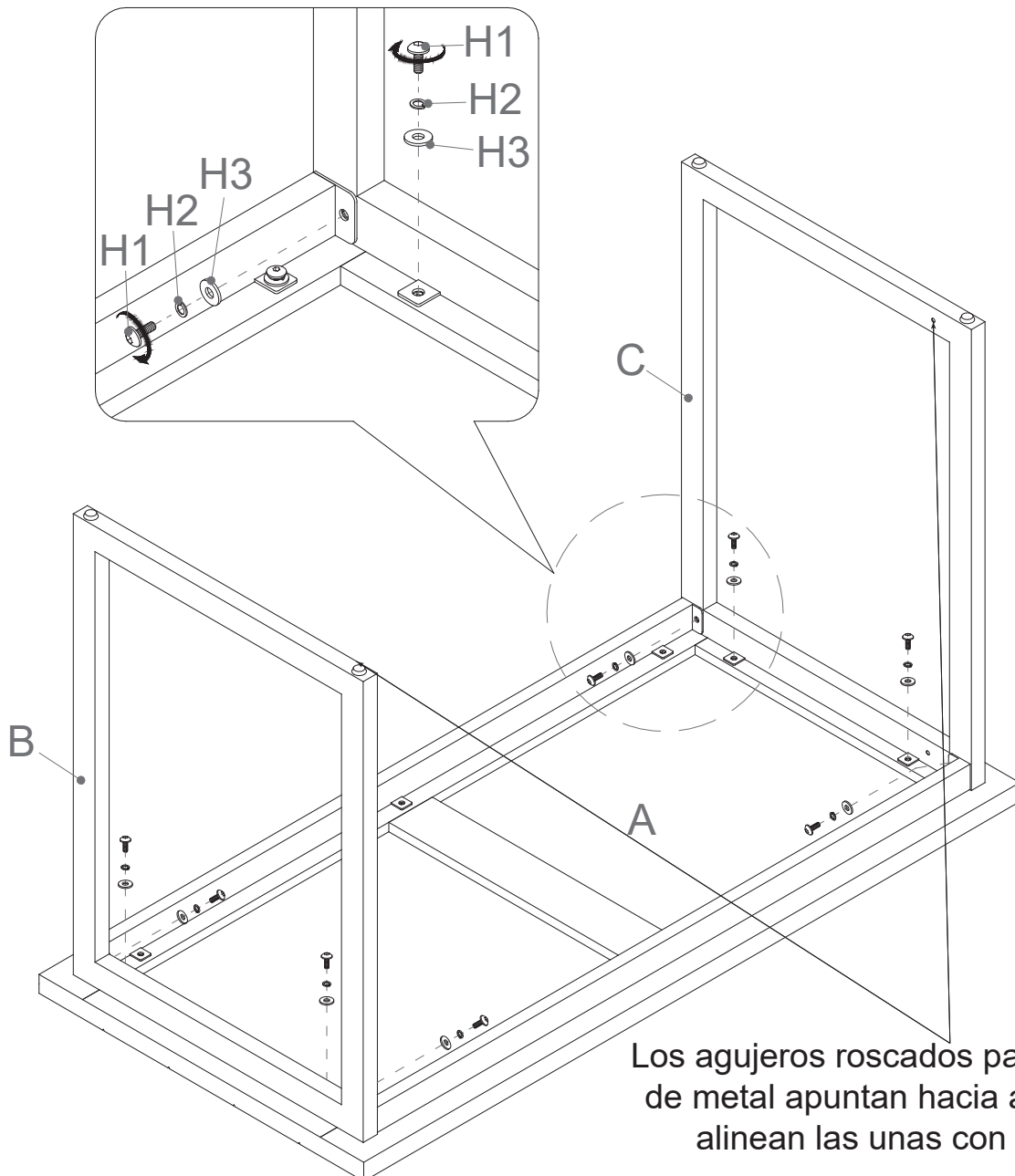

Alinear y adjuntar los marcos laterales (B y C) al panel superior (A) con 4 pernos de 19 mm (H1) y sus arandelas (H2 y H3).

Proceda a fijar los marcos laterales (B y C) a los soportes (D) con 4 pernos de 19 mm (H1) y sus arandelas (H2 y H3).

Paso 3

(H1)
Perno de
1/4" x 19 mm
Cant: 2

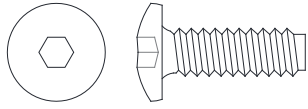

(H2)
Arandela de
presión
Cant: 2



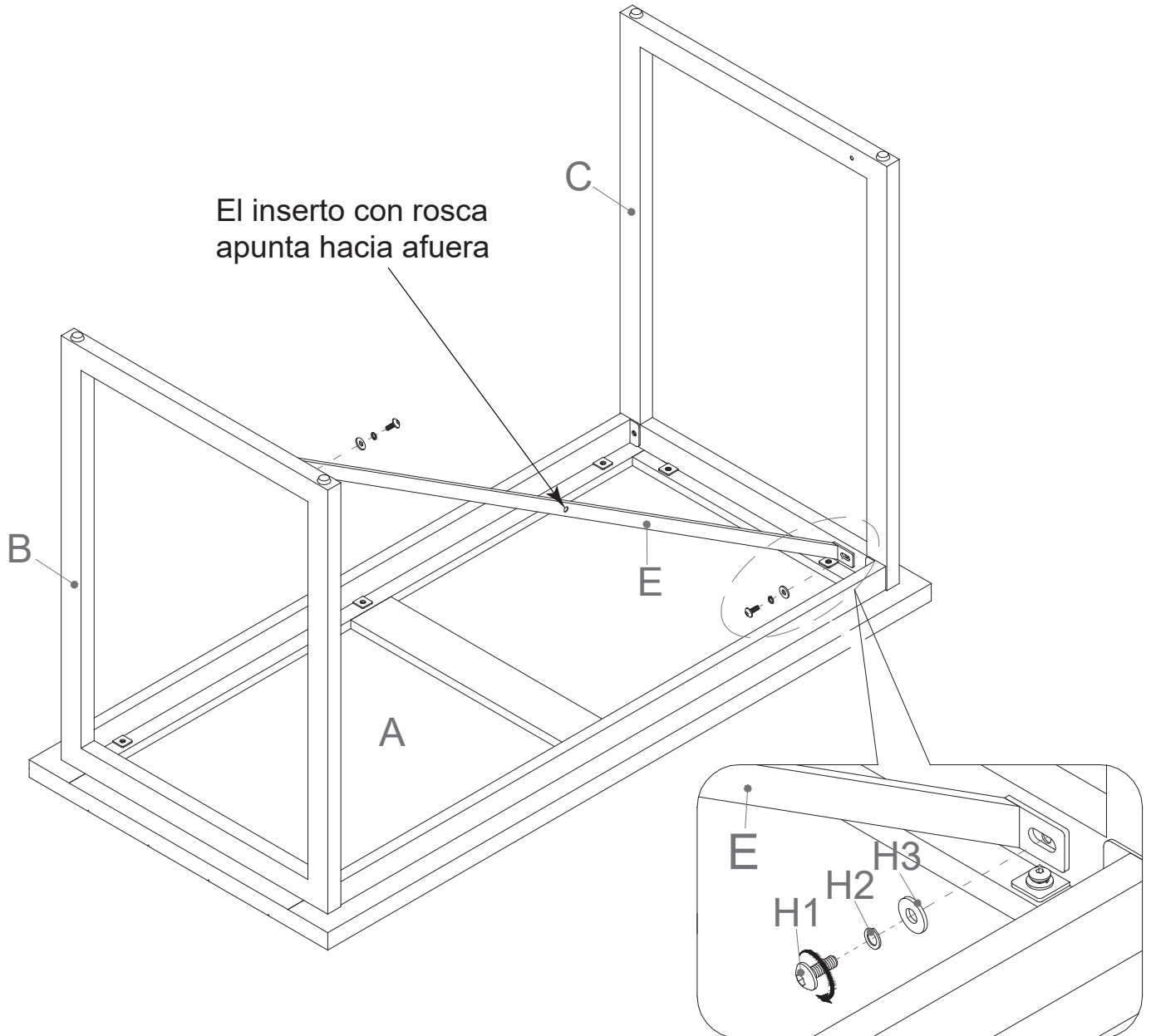
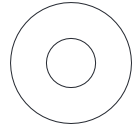

(H3)
Arandela
plana
Cant: 2

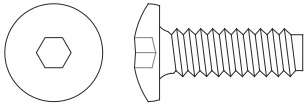

Alinear y adjuntar la barra de metal frontal (E) a los marcos laterales (B y C) con 2 pernos de 19 mm (H1) y sus arandelas (H2 y H3). No apretar los pernos.

Paso 4

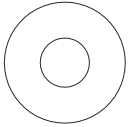
(H1) Perno de 1/4" x 19 mm Cant: 3		(H2) Arandela de presión Cant: 3		(H3) Arandela plana Cant: 3	
--	---	--	--	---	---

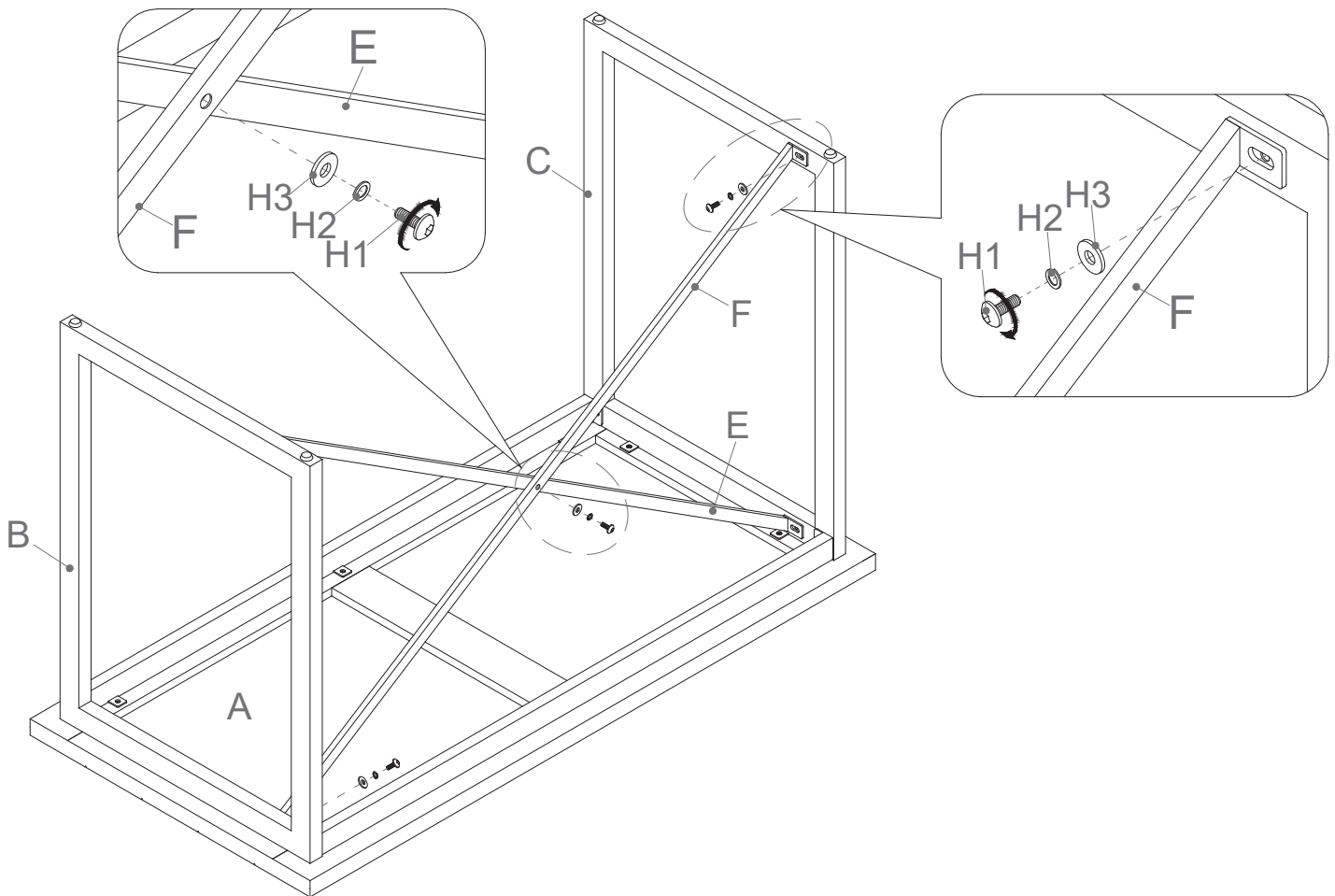

Repetir paso para sujetar la barra de metal posterior (F) a los marcos laterales (B y C). Continuar a sujetar la barra de metal posterior (F) a la barra de metal frontal (E) con un perno de 19 mm (H1) y sus arandelas (H2 y H3).

Ahora, volver y apretar todos los pernos, asegurar que todas las partes estén apretadas y de que no hay huecos entre las partes, esto ayudara a mantener la unidad cuadrada.

Paso 5

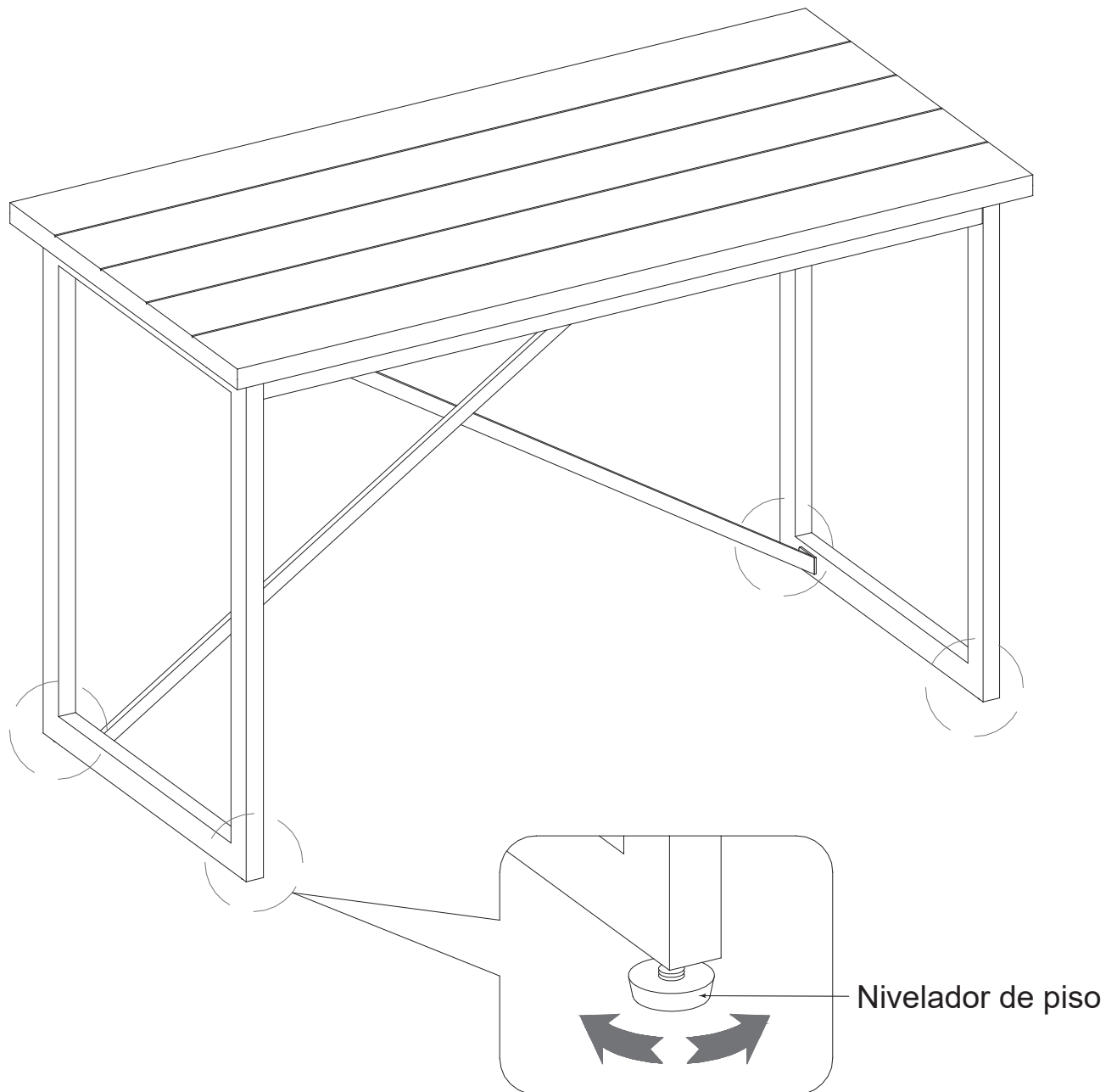

Pedir asistencia para posicionar la unidad ensamblada en posición vertical y en el lugar deseado. Si fuera necesario, ajustar los niveladores de piso pre-adjuntados para corregir la inclinación.