

# Origin 21

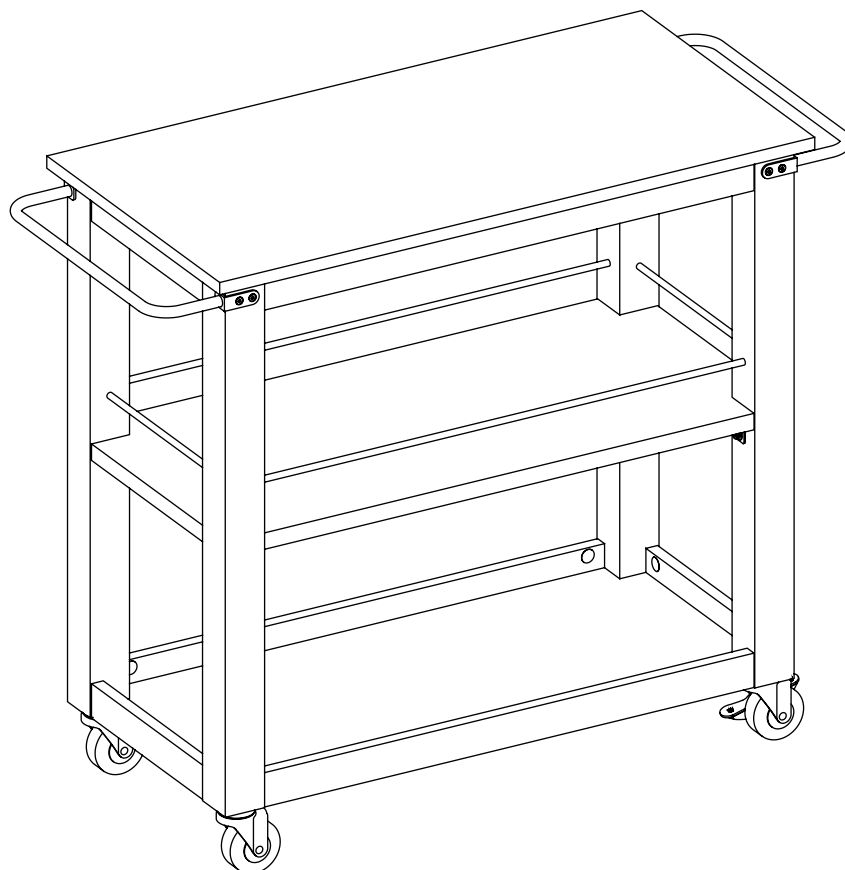

ORIGIN 21 and logo design are trademarks or registered trademarks of LF, LLC. All rights reserved.

ITEM #4350898

## KITCHEN CART WITH RUBBERWOOD TOP

MODEL #LWS35KCR

Français p. 12

Español p. 23

### ATTACH YOUR RECEIPT HERE

Serial Number \_\_\_\_\_ Purchase Date \_\_\_\_\_

**Questions, problems, missing parts?** Before returning to your retailer, call our customer service department at (888) 251-1026, 8 a.m. - 8 p.m., EST, Monday - Sunday. You could also contact us at [partsplus@lowes.com](mailto:partsplus@lowes.com).

## TABLE OF CONTENTS

---

Camlock System Operation.....	2
Package Contents.....	3
Hardware Contents.....	4
Safety Information.....	5
Preparation .....	5
Assembly Instructions.....	6
Care and Maintenance .....	9
Limited Lifetime Warranty.....	9
Replacement Parts List .....	10

## CAM LOCK SYSTEM OPERATION

---

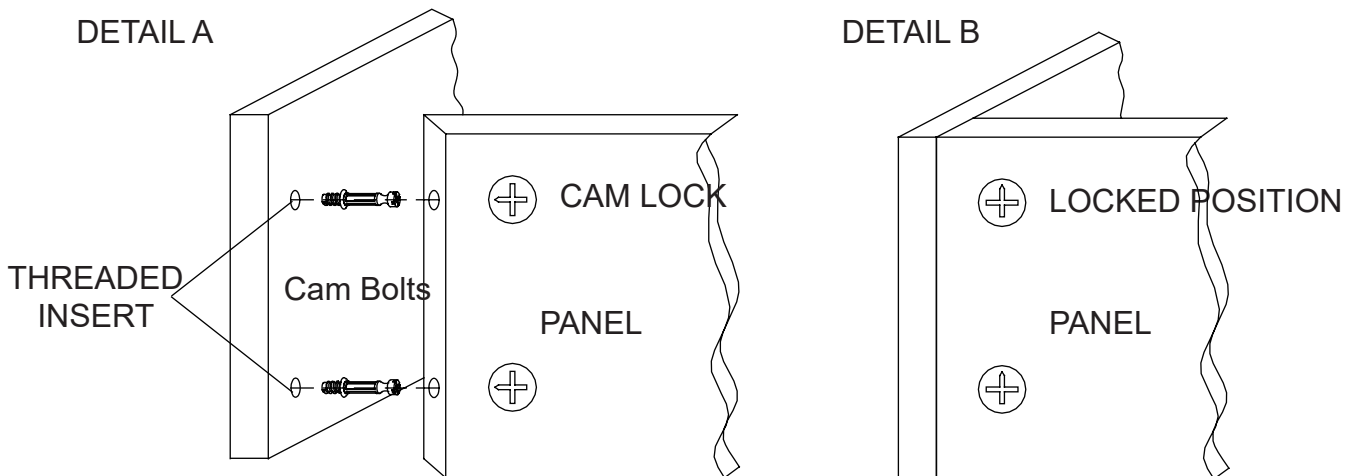

1. Screw cam bolts into the predrilled small holes on panel.
2. Insert cam lock into predrilled large hole on panel.
3. Make sure the arrow on the cam lock is pointed toward the cam bolts.
4. Connect both panels together, making sure cam bolts goes into predrilled hole on the end of panel with cam lock.
5. Once cam bolts is connected inside cam lock, take Phillips screwdriver and tighten cam lock clockwise.

## PACKAGE CONTENT

PART	DESCRIPTION	QUANTITY
A	Top Panel	1
B	Left Back Post	1
C	Left Front Post	1
D	Right Back Post	1
E	Right Front Post	1
F	Upper Stretcher	2
G	Upper Side Stretcher	2
H	Long Metal Stretcher	2

PART	DESCRIPTION	QUANTITY
I	Short Metal Stretcher	2
J	Shelf	1
K	Lower Stretcher	2
L	Lower Side Stretcher	2
M	Bottom Panel	1
N	Handle	2
O	Caster	2
P	Caster With Brake	2

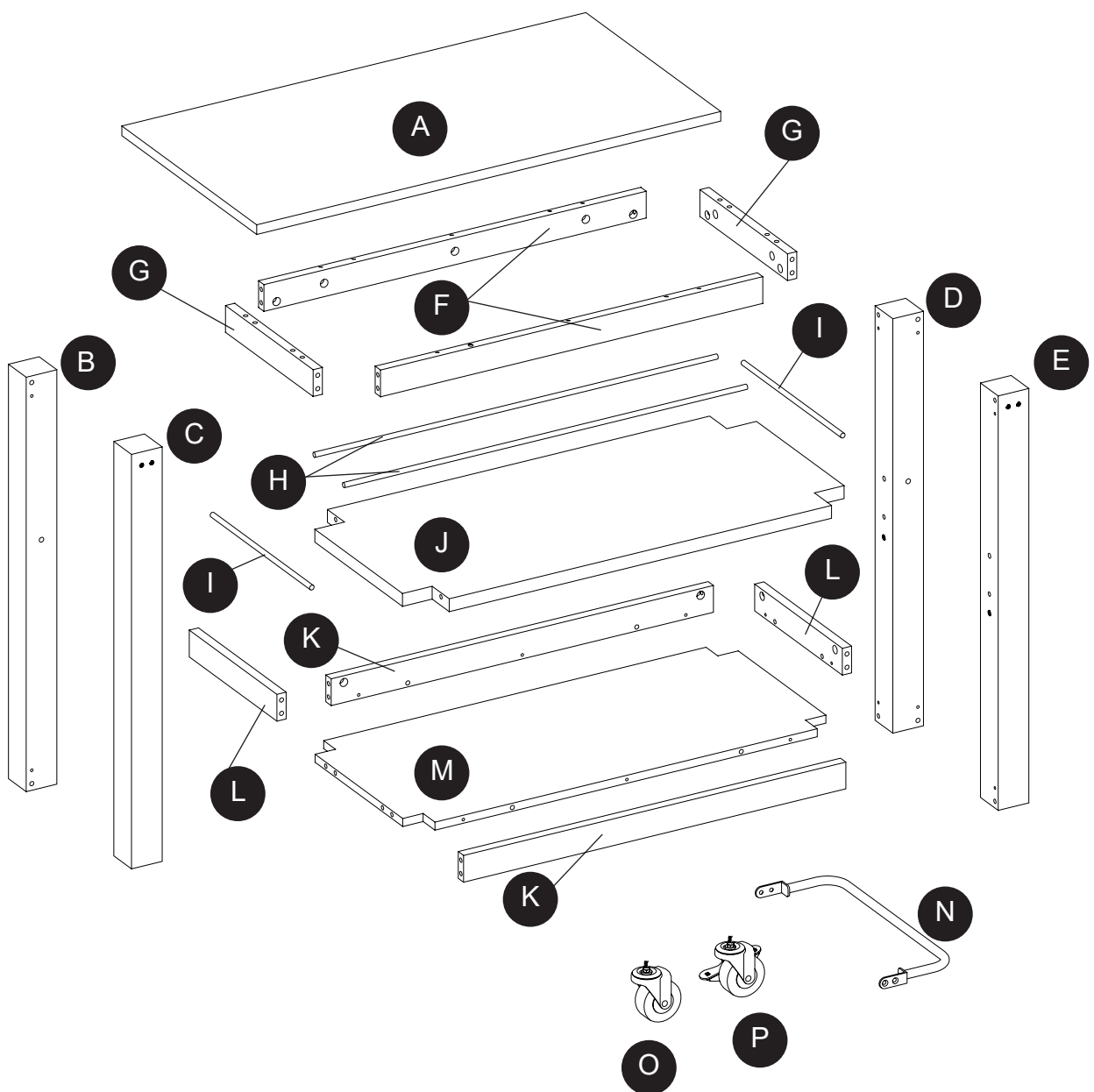

**HARDWARE CONTENTS** (shown not actual size)

---

AA

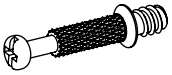

Cam Bolt

Qty. 36

BB



Cam Lock

Qty. 36

CC



Wood Dowel

Qty. 36

DD

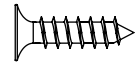

M4 x 17mm Screw

Qty. 8

EE

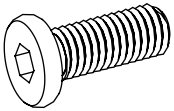

1/4"x 15 mm Bolt

Qty. 4

FF

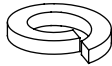

1/4" Lock Washer

Qty. 4

GG

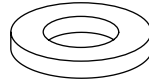

1/4" Flat Washer

Qty. 4

HH

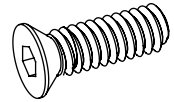

1/4"x 15 mm  
Sala Bolt  
Qty. 8

II

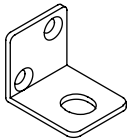

L metal plate

Qty. 4

JJ

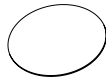

PVC Cover

Qty. 26

KK

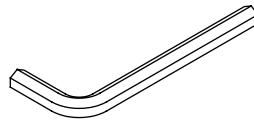

Allen Wrench

Qty. 1

LL

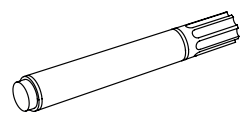

Touch up Pen

Qty. 1

## **! SAFETY INFORMATION**

---

Please read and understand this entire manual before attempting to assemble or install the product.

1. Please read the Assembly Instructions prior to assembling the unit.
2. To avoid damage, assemble the unit on a sturdy, level and non-abrasive surface.
3. Keep all hardware and parts out of the reach of children.
4. Please wait until all steps are completed before fully tightening bolts.
5. Make sure all bolts and screws are tightly fastened before the unit is used.
6. Check that all bolts, screws are tight at least every 3 months or as needed.

## **! WARNING**

THIS UNIT IS INTENDED FOR USE ONLY WITH THE MAXIMUM WEIGHTS INDICATED. USE WITH PRODUCTS HEAVIER THAN THE MAXIMUM WEIGHTS INDICATED MAY RESULT IN INSTABILITY CAUSING POSSIBLE INJURY. DISTRIBUTE WEIGHT EVENLY.

TOP MAXIMUM:  
45.4kg / 100 lb  
EVENLY DISTRIBUTED.

SHELF MAXIMUM:  
13.6kg / 30 lb  
EVENLY DISTRIBUTED.

ENTIRE UNIT MAXIMUM  
WEIGHT CAPACITY:  
72.7kg / 160 lb  
EVENLY DISTRIBUTED

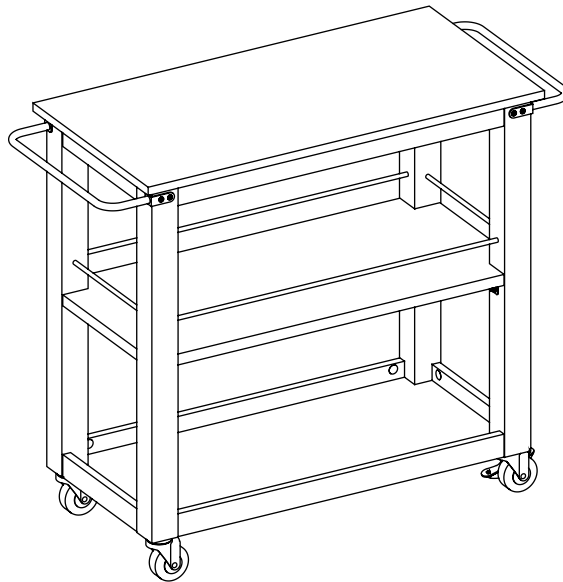

## **PREPARATION**

---

Please read the instruction sheets completely before assembly. Examine all packaging material before discarding carton. Remove any remaining staples from the carton before discarding. Remove all parts from carton and separate into groups as indicated on part list. Please ensure all parts are included prior to assembly. Use of power tools must be with caution and ensuring setting at low-torque, avoid damaging the wood panels.

**Estimated Assembly Time: 60 minutes.**

Tools Required for Assembly: Phillips screwdriver, stud finder, marking pencil, tape measure, power drill and drill bits.

## ASSEMBLY INSTRUCTIONS

1. Insert cam bolts (AA) into left back post (B), left front post (C), right back post (D), right front post (E), lower stretcher (K), and lower side stretcher (L).

### Hardware Used

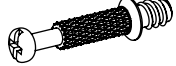
AA Cam Bolt  x 26

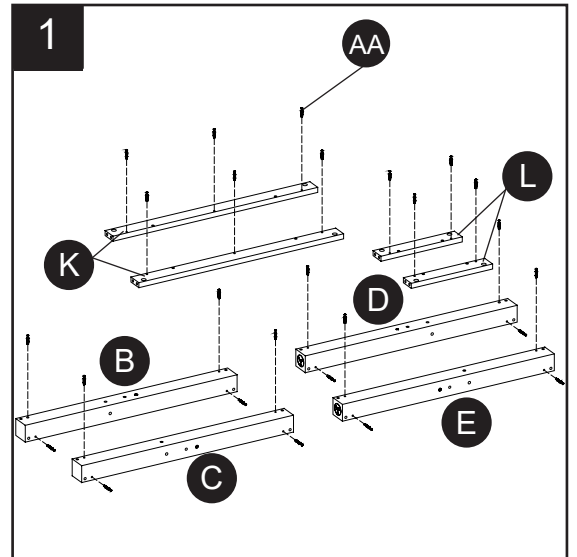

2. Attach lower stretcher (K) to bottom panel (M) using wood dowels (CC) and cam locks (BB).

### Hardware Used

BB Cam Lock  x 6

CC Wood Dowel  x 4

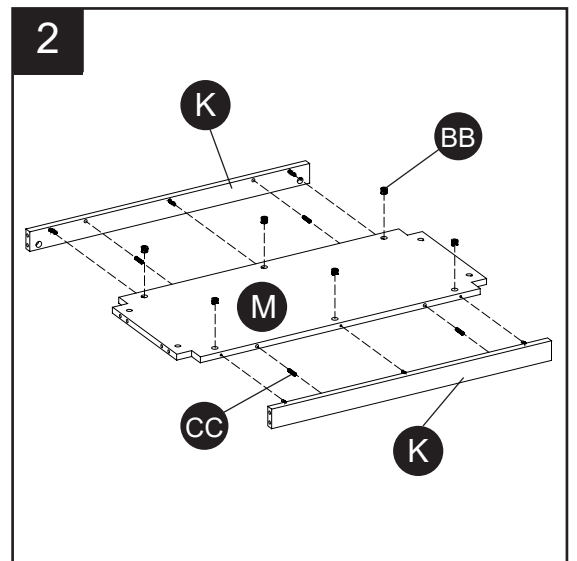

3. Attach left back post (B), upper side stretcher (G), short metal stretcher (I), and lower side stretcher (L) to left front post (C), attach right back post (D), upper side stretcher (G), short metal stretcher (I), and lower side stretcher (L) to right front post (E), using wood dowels (CC) and cam locks (BB).

### Hardware Used

BB Cam Lock  x 8

CC Wood Dowel  x 8

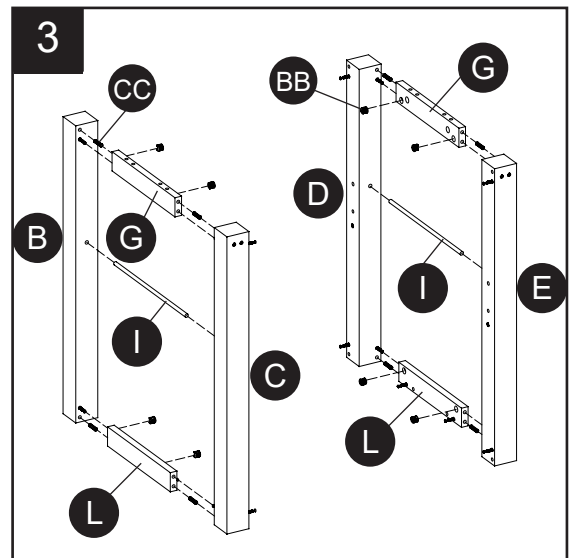

## ASSEMBLY INSTRUCTIONS

4. Insert cam bolts (AA) into top panel (A) .

### Hardware Used

AA Cam Bolt x 10

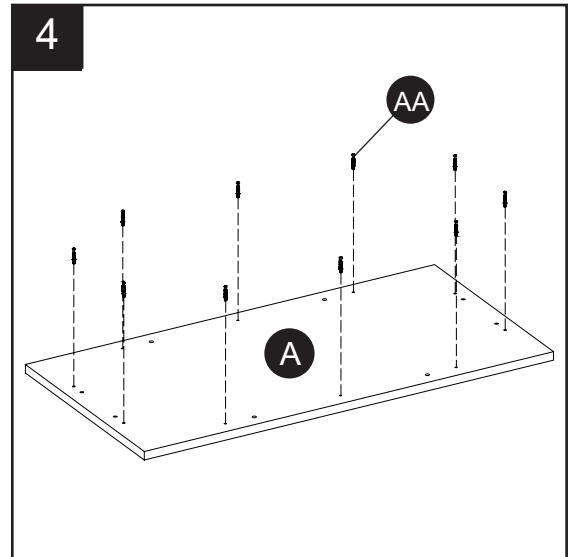
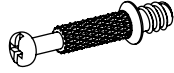

5. Install the L metal plate (II) to pilot hole of the shelf (J), tighten with screws (DD).

### Hardware Used

DD M4 x 17 mm Screw x 8

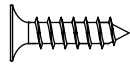

II L Metal Plate x 4

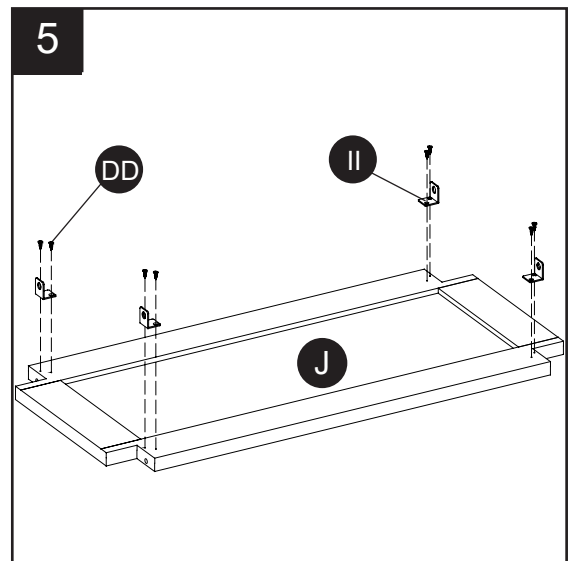
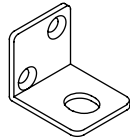

6. Attach left back post (B), left front post (C), upper stretcher (F), long metal stretcher (H), shelf (J) and lower stretcher (K), bottom panel (M) to right back post (D), right front post (E), using wood dowels (CC) and cam locks (BB).

### Hardware Used

BB Cam Lock x 12



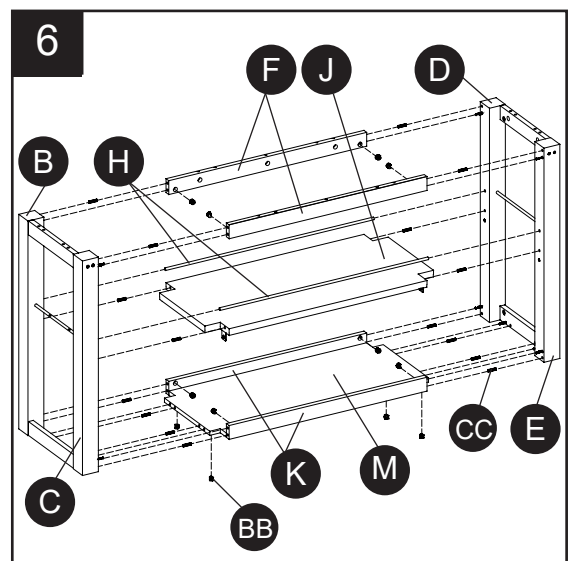
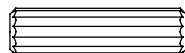

CC Wood Dowel x 16



## ASSEMBLY INSTRUCTIONS

7. Attach left back post (B), left front post (C), upper stretcher (F), upper side stretcher (G), right back post (D), right front post (E) to top panel (A), using wood dowels (CC) and cam locks (BB).

### Hardware Used



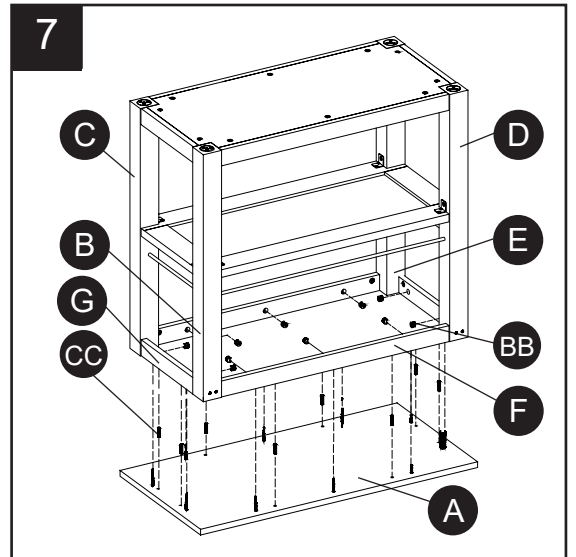

<b>BB</b> Cam Lock		x 10
<b>CC</b> Wood Dowel		x 8

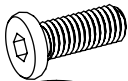

8. Install caster (O) and caster with brake (P) into the bottom of post T- nut.

Using allen wrench (KK), 1/4" x 15 mm bolt (EE), 1/4" lock washer (FF), 1/4" flat washer (GG) to tighten shelf (J) on the post.

### Hardware Used

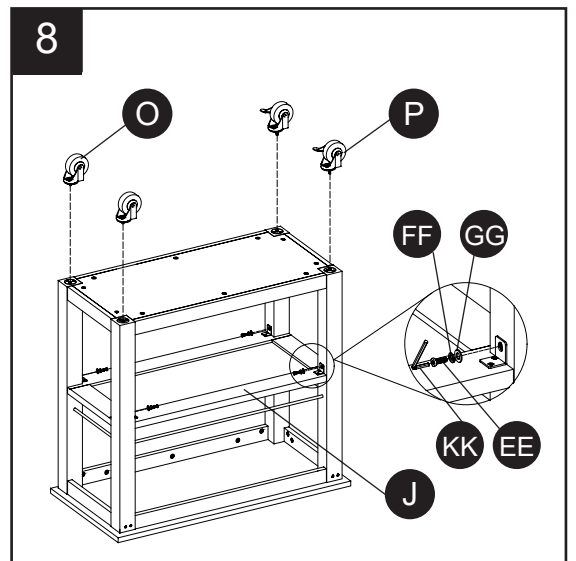

<b>EE</b> 1/4"x 15 mm Bolt		x 4
<b>FF</b> 1/4" Lock Washer		x 4
<b>GG</b> 1/4" Flat Washer		x 4
<b>KK</b> Allen Wrench		x 1



9. Using allen wrench (KK) and 1/4" x 15 mm sala bolt (HH) to tighten handle(N) on left back post (B), left front post (C), right back post (D), right front post (E).

All expose cam lock holes covered with PVC cover (JJ)

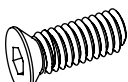
### Hardware Used

<b>HH</b> 1/4"x 15 mm Sala Bolt		x 8
<b>JJ</b> PVC cover		x 26
<b>KK</b> Allen Wrench		x 1

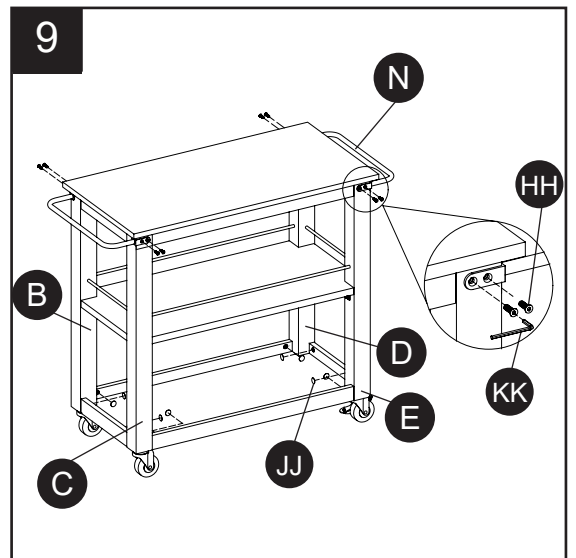



## **CARE AND MAINTENANCE**

---

- Use a soft, clean cloth that will not scratch the surface when dusting.
- Use of furniture polishes is not necessary. Should you choose to use polishes, test first in an inconspicuous area.
- Using solvents of any kind on your furniture may damage the finish.
- Never use water to clean your furniture as it may cause damage to the finish.
- Always use coasters under beverage glasses and flowerpots.
- Liquid spills should be removed immediately. Using a soft clean cloth, blot the spill gently. Avoid rubbing.
- Always use protective pads under hot dishes and plates. Heat can cause chemical changes that may create spotting within the furniture finish.
- Stains or marks from crayons or ink markers will be difficult to remove.
- In the event that your furniture is stained or otherwise damaged during use, we recommend that you call a professional to repair your furniture.
- Check bolts/nuts periodically and tighten them if necessary.
- Touch-up Pen (LL) has been provided to repair any small nicks or scratches that may occur during assembly or shipping.

## **LIMITED LIFETIME WARRANTY**

---

This product is warranted to the original purchaser. If there is a failure in this unit due to defects in materials or workmanship, the manufacturer will repair or replace this item at our discretion without charge. Warranty is void if product has been assembled incorrectly, misused, abused by overloading, altered in any way or damaged due to accident. This warranty is not transferable and does not cover chipping, flaking, scratches, rust, dents, or other damages to the surfaces of this product. Responsibility of the manufacturer is limited to repair or replacement of this product. The manufacturer is not responsible for consequential, incidental, or other damages or losses resulting from product failure.

This warranty is in lieu of all other expressed warranties. Some states do not allow the exclusion or limitation of incidental or consequential damages, so the above limitation may not apply to you. This warranty gives you specific legal rights and you may have other rights which vary from state to state.

## REPLACEMENT PARTS LIST

---

For replacement parts, call our customer service department at (888) 251-1026, 8 a.m. - 8 p.m., EST, Monday - Sunday. You could also contact us at [partsplus@lowes.com](mailto:partsplus@lowes.com) or visit [www.lowespartsplus.com](http://www.lowespartsplus.com).

PART	DESCRIPTION	PART #
A	Top Panel	00LWS35KCR-01
B	Left Back Post	00LWS35KCR-02
C	Left Front Post	00LWS35KCR-03
D	Right Back Post	00LWS35KCR-04
E	Right Front Post	00LWS35KCR-05
F	Upper Stretcher	00LWS35KCR-06
G	Upper Side Stretcher	00LWS35KCR-07
H	Long Metal Stretcher	00LWS35KCC-CR-08
I	Short Metal Stretcher	00LWS35KCC-CR-09
J	Shelf	00LWS35KCR-10
K	Lower Stretcher	00LWS35KCR-11
L	Lower Side Stretcher	00LWS35KCR-12
M	Bottom Panel	00LWS35KCR-13
N	Handle	00LWS35KCC-CR-14
O	Caster	00LWS35KCC-CR-15
P	Caster With Brake	00LWS35KCC-CR-16
AA	Cam Bolt	00LWS35KCC-CR-17
BB	Cam Lock	00LWS35KCC-CR-18
CC	Wood Dowel	00LWS35KCC-CR-19
DD	M4 x 17mm Screw	00LWS35KCC-CR-20
EE	1/4"x 15 mm Bolt	00LWS35KCC-CR-21
FF	1/4" Lock Washer	00LWS35KCC-CR-22
GG	1/4" Flat Washer	00LWS35KCC-CR-23
HH	1/4"x 15 mm Sala Bolt	00LWS35KCC-CR-24
II	L metal plate	00LWS35KCC-CR-25
JJ	PVC Cover	00LWS35KCC-CR-26
KK	Allen Wrench	00LWS35KCC-CR-27
LL	Touch up Pen	00LWS35KCC-CR-28

# REPLACEMENT PARTS LIST

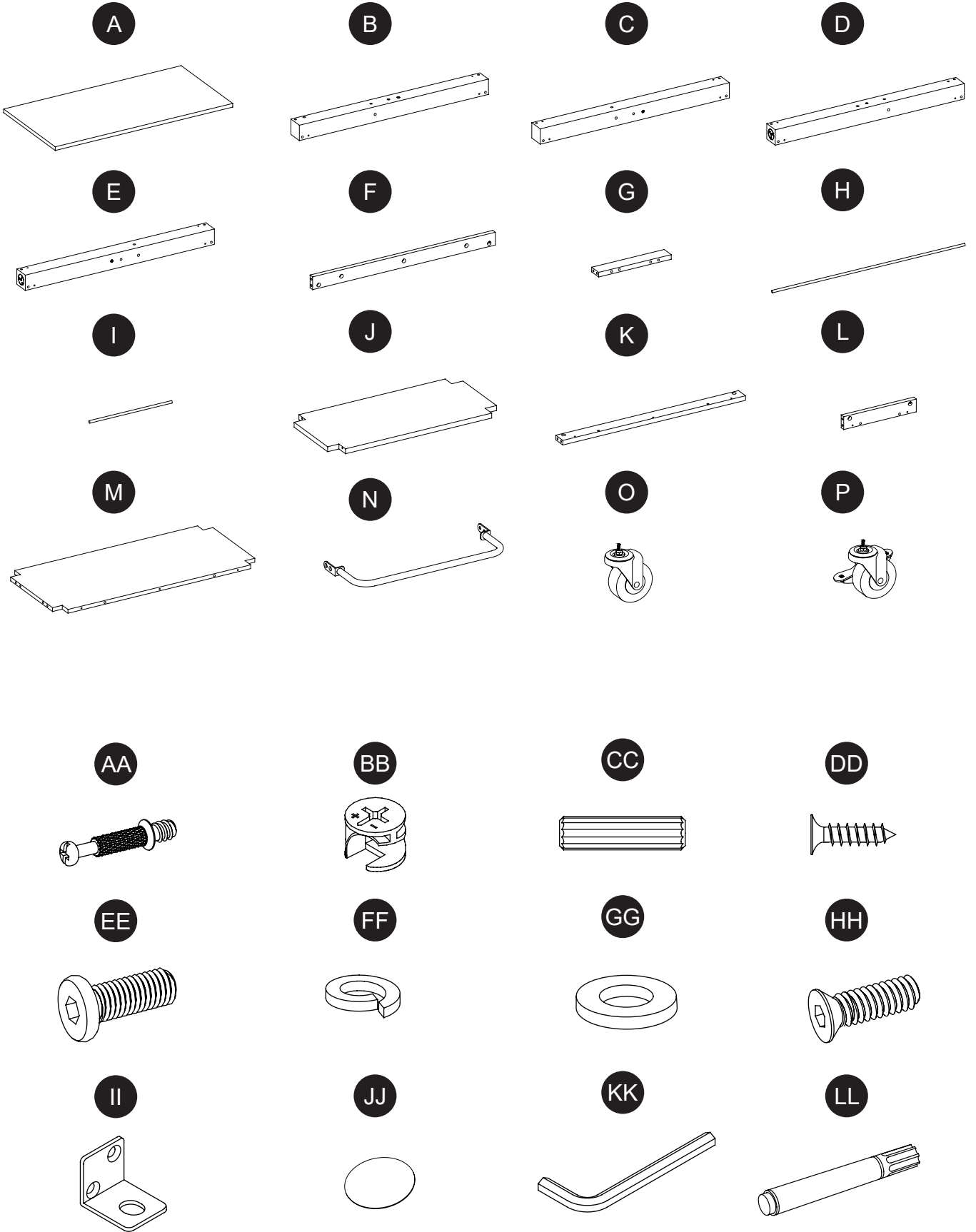

# Origin 21

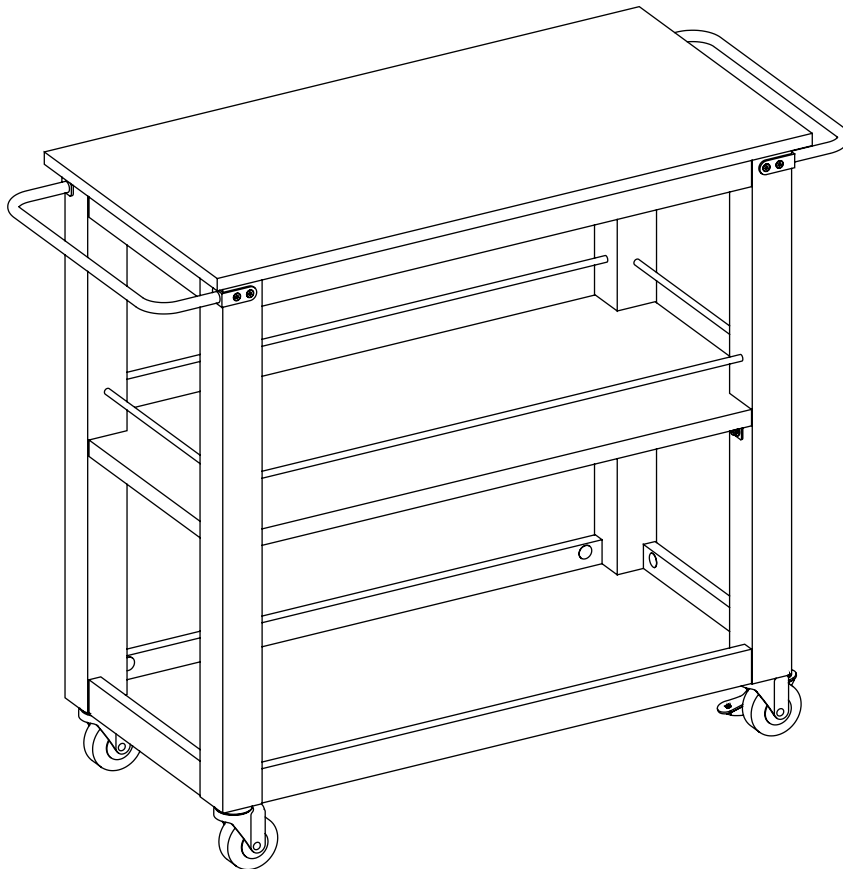

ORIGIN 21 ainsi que le logo sont des marques ou des marques déposées de LF, LLC. Tous droits réservés.

ARTICLE N° 4350898

## CHARIOT DE CUISINE AVEC TOIT EN CAOUTCHOUC

MODÈLE N° LWS35KCR

Français p. 12

Español p. 23

**JOINDRE VOTRE REÇU ICI**

Numéro de série \_\_\_\_\_ Date d'achat \_\_\_\_\_

**Des questions, des problèmes, des pièces manquantes?** Avant de retourner l'article au détaillant, appelez notre service à la clientèle au (888) 251-1026, entre 8 h et 20 h (HNE), du lundi au dimanche. Vous pouvez également nous contacter à [partsplus@lowes.com](mailto:partsplus@lowes.com).

AS21712

## TABLE DES MATIÈRES

---

Fonctionnement du système Camloc .....	13
Contenu de l'emballage.....	14
Contenu de la quincaillerie.....	15
Consignes de sécurité.....	16
Préparation .....	16
Instructions de montage.....	17
Soin et entretien .....	20
Garantie limitée à vie.....	20
Liste des pièces de remplacement.....	21

## FONCTIONNEMENT DU SYSTÈME CAMLOC

---

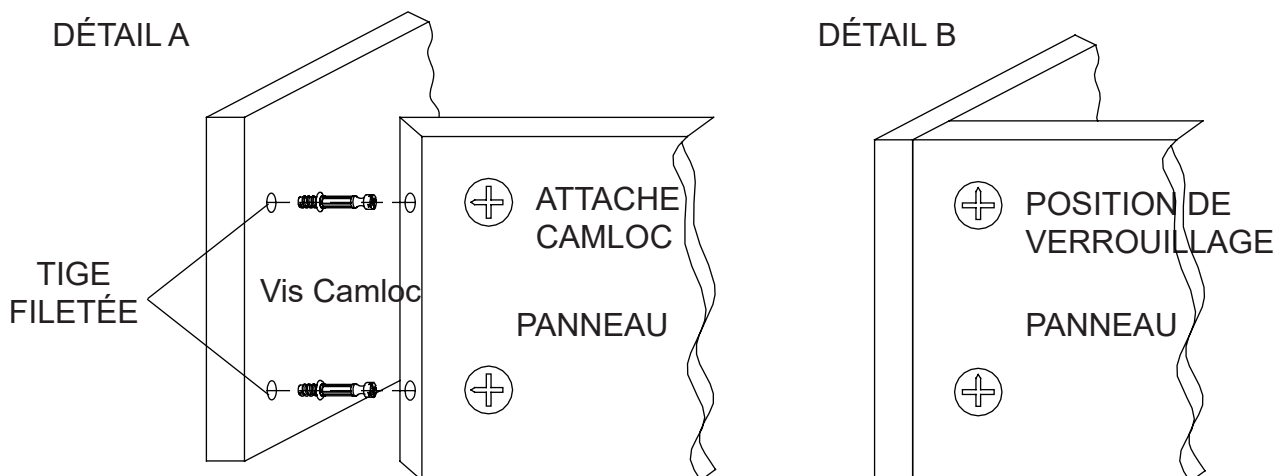

1. Vissez les vis Camloc dans les petits trous déjà percés sur le panneau.
2. Insérez les attaches Camloc dans les grands trous déjà percés sur le panneau.
3. Assurez-vous que les flèches sur les attaches Camloc pointent vers les vis Camloc.
4. Reliez les deux panneaux ensemble, en vous assurant que les vis Camloc s'insèrent correctement dans les trous déjà percés situés à l'extrémité du panneau sur lequel sont installées les attaches Camloc.
5. Une fois les vis Camloc insérées dans les attaches Camloc, serrez les attaches Camloc dans le sens des aiguilles d'une montre à l'aide d'un tournevis cruciforme.

## CONTENU DE L'EMBALLAGE

PIÈCE	DESCRIPTION	QUANTITÉ	PIÈCE	DESCRIPTION	QUANTITÉ
A	Panneau supérieur	1	I	Brancard métallique court	2
B	Support arrière gauche	1	J	Étagère	1
C	Support avant gauche	1	K	Brancard inférieur	2
D	Support arrière droit	1	L	Brancard de côté inférieure	2
E	Support avant droit	1	M	Panneau inférieur	1
F	Brancard supérieur	2	N	Poignée	2
G	Brancard de côté supérieur	2	O	Roulette	2
H	Brancard métallique long	2	P	Roulette avec frein	2

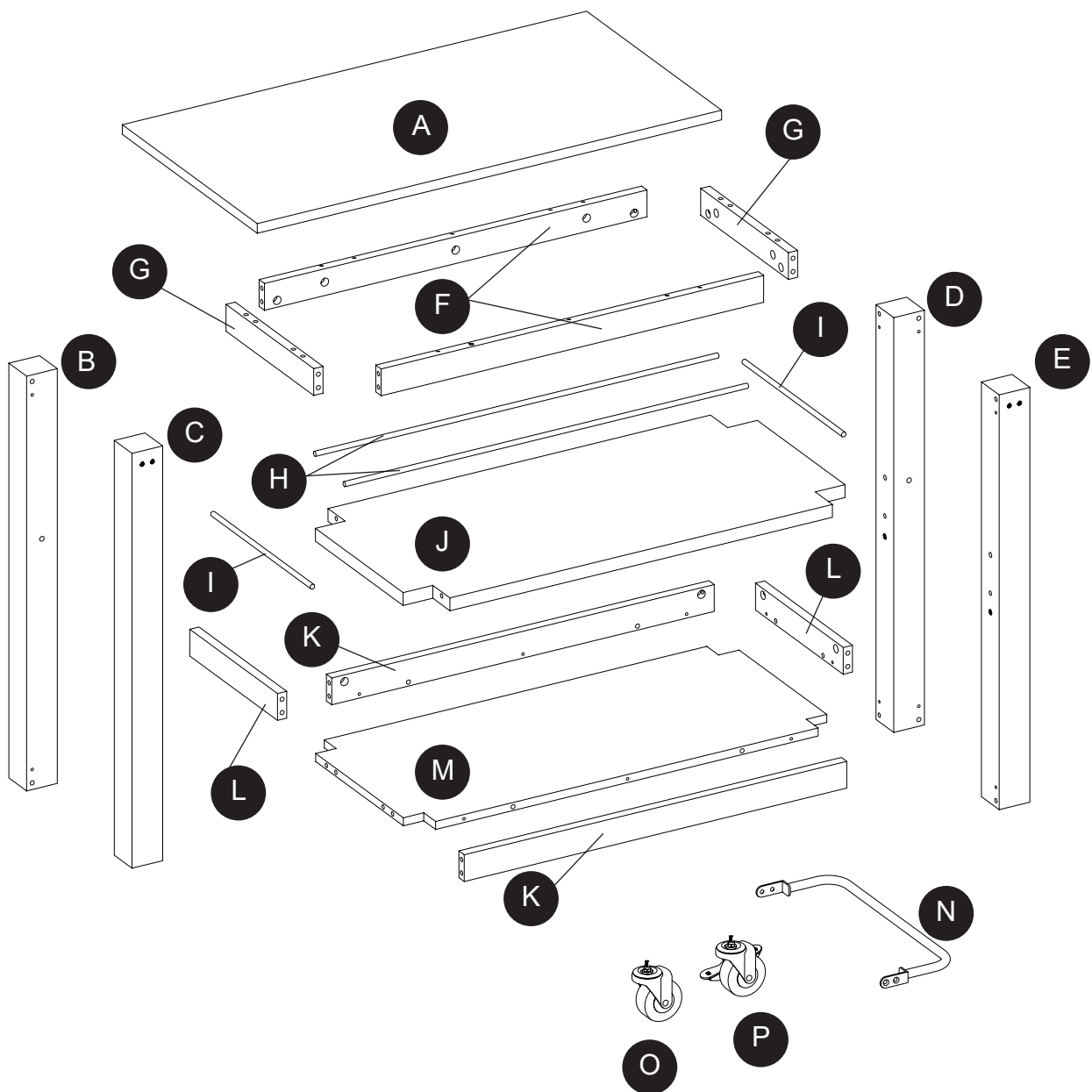

**CONTENU DE LA QUINCAILLERIE (non illustrée à la grandeur réelle)**

---

AA

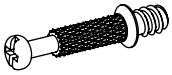

Vis Camloc

Qté. 36

BB



Attache Camloc

Qté. 36

CC

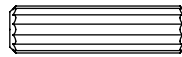

Goujon de bois

Qté. 36

DD

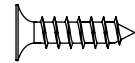

Vis M4 x 17 mm

Qté. 8

EE

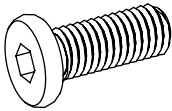

Boulon  
1/4" x 15mm  
Qté. 4

FF

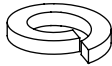

1/4" Rondelle de  
blocage  
Qté. 4

GG

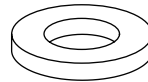

1/4" Rondelle  
plate  
Qté. 4

HH

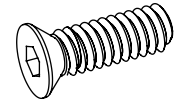

1/4"x 15 mm  
Boulons Sala  
Qté. 8

II

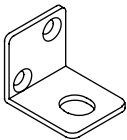

Plaque  
métallique L  
Qté. 4

JJ

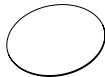

Couvercle en PVC  
Qté. 26

KK

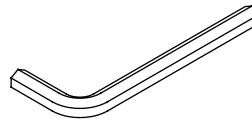

Clé Allen  
Qté. 1

LL

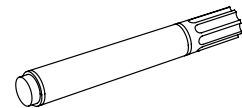

Crayon à retouche  
Qté. 1

## **! CONSIGNES DE SÉCURITÉ**

---

Lire et comprendre le présent guide avant de monter ou d'installer le produit.

1. Lire les Instructions de montage avant d'assembler l'unité.
2. Pour éviter les dommages, assembler l'unité sur une surface solide, de niveau et non abrasive.
3. Garder toute la quincaillerie et les pièces hors de portée des enfants.
4. Attendre que toutes les étapes soient complétées avant de serrer les boulons à fond.
5. S'assurer que tous les boulons et les vis soient solidement fixés avant d'utiliser l'unité.
6. S'assurer tous les trois mois ou au besoin que les boulons, les vis soient solides.

## **! AVERTISSEMENT**

CETTE UNITÉ DOIT ÊTRE UTILISÉE UNIQUEMENT SELON LES POIDS MAXIMAUX INDIQUÉS. L'UTILISATION AVEC DES PRODUITS PLUS LOURDS QUE LES LIMITES MENTIONNÉES PEUT CAUSER DE L'INSTABILITÉ ET DES BLESSURES. RÉPARTIR LE POIDS ÉGALEMENT.

CAPACITÉ MAXIMALE  
DE PANNEAU SUPÉRIEUR:  
45.4kg / 100 lb  
RÉPARTIS ÉGALEMENT.

CAPACITÉ MAXIMALE  
DE ÉTAGÈRE:  
13.6kg / 30 lb  
EVENLY DISTRIBUTED.

CAPACITÉ MAXIMALE DE  
L'UNITÉ:  
72.7 kg / 160 lb  
RÉPARTIS ÉGALEMENT.

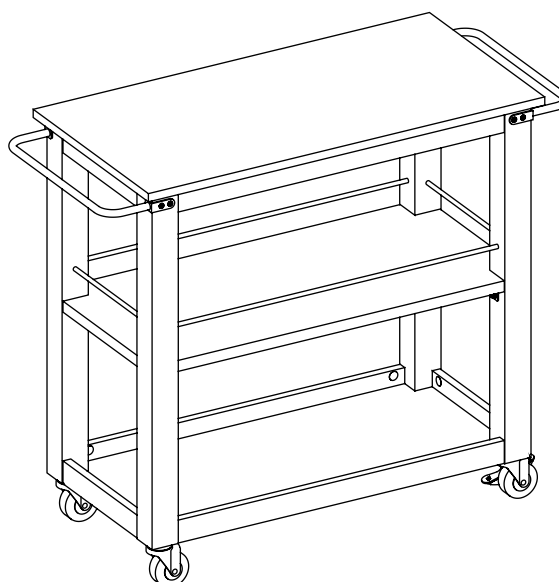

## **PRÉPARATION**

---

Avant de débuter le montage de ce produit, s'assurer d'avoir toutes les pièces indiquées. Comparer les pièces avec la liste du contenu de l'emballage et de la quincaillerie. En cas de pièce manquante ou endommagée, ne pas tenter de monter le produit.

**Durée approximative du montage : 60 minutes.**

Outils nécessaires pour l'assemblage: tournevis cruciforme, détecteur de montants, crayon, ruban à mesurer, perceuse électrique, foret.



## INSTRUCTIONS DE MONTAGE

1. Insérer les boulons à came (AA) dans le support arrière gauche (B), le support avant gauche (C), le support arrière droit (D), le support avant droit (E), le brancard inférieur (K) et le brancard de côté inférieure (L).

### Quincaillerie utilisée

AA Vis Camloc  x 26

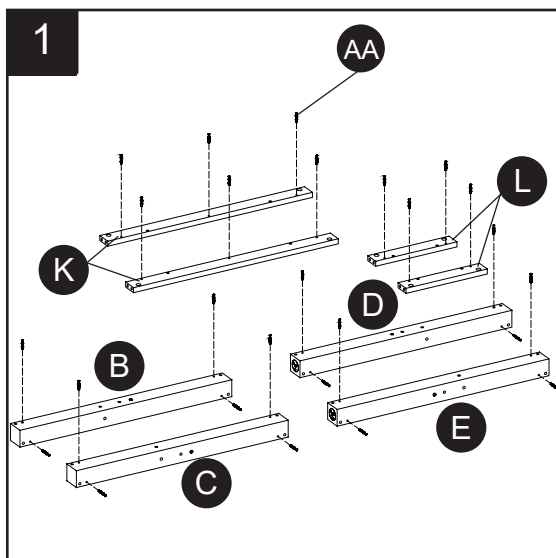

2. Fixer le brancard inférieur (K) au panneau inférieur (M) à l'aide de chevilles en bois (CC) et de verrous à came (BB).

### Quincaillerie utilisée

BB Attache Camloc  x 6

CC Goujon de bois  x 4

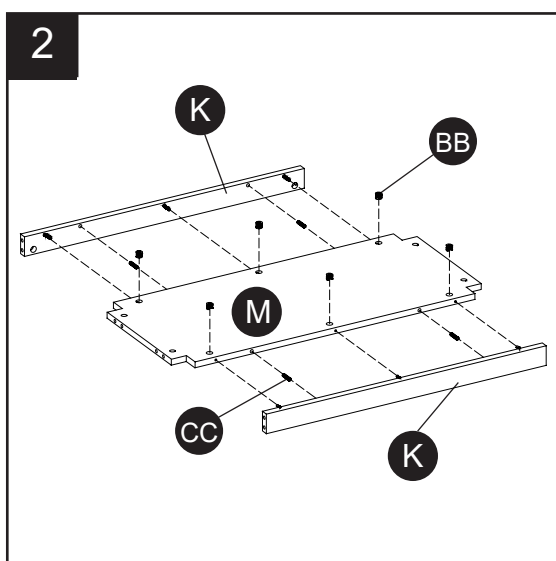

3. Fixer le montant arrière gauche (B), le brancard de côté supérieur (G), le brancard métallique court (I) et le brancard de côté inférieure (L) au support avant gauche (C), fixer le support arrière droit (D), le brancard de côté supérieur (G), le brancard métallique court (I) et le brancard de côté inférieure (L) au montant avant droit (E), à l'aide de chevilles en bois (CC) et de verrous à came (BB).

### Quincaillerie utilisée

BB Attache Camloc  x 8

CC Goujon de bois  x 8

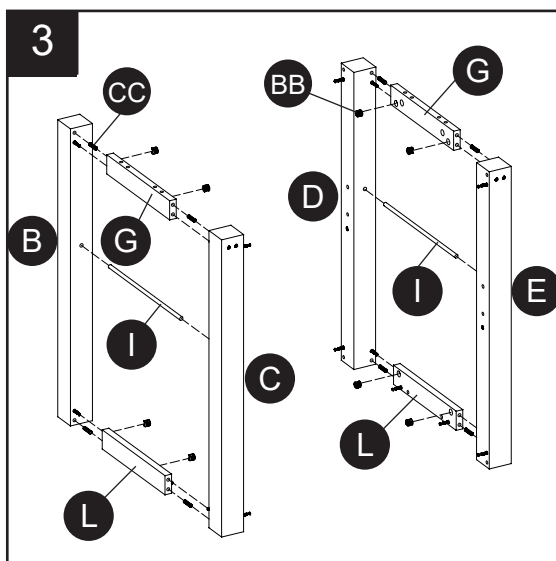

## INSTRUCTIONS DE MONTAGE

4. Insérer les boulons à came (AA) dans le panneau supérieur (A).

### Quincaillerie utilisée

AA Vis Camloc x 10

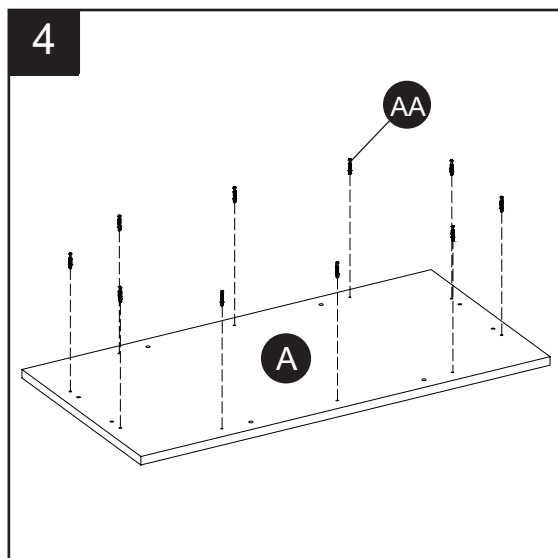
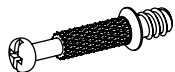

5. Installer la plaque métallique L (II) dans le trou pilote de l'étagère (J), serrer à l'aide des vis (DD).

### Quincaillerie utilisée

DD Vis M4 x 17 mm x 8

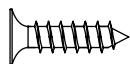

II Plaque métallique L x 4

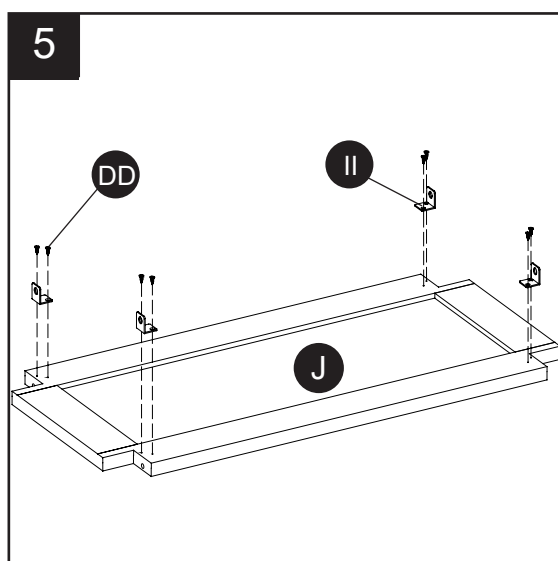
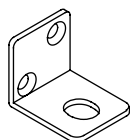

6. Fixer le montant arrière gauche (B), le support avant gauche (C), le brancard supérieur (F), le brancard métallique long (H), l'étagère (J) et le brancard inférieur (K), le panneau inférieur (M) au support arrière droit (D), au support avant droit (E), en utilisant des chevilles en bois (CC) et des verrous à came (BB).

### Quincaillerie utilisée

BB Attache Camloc x 12



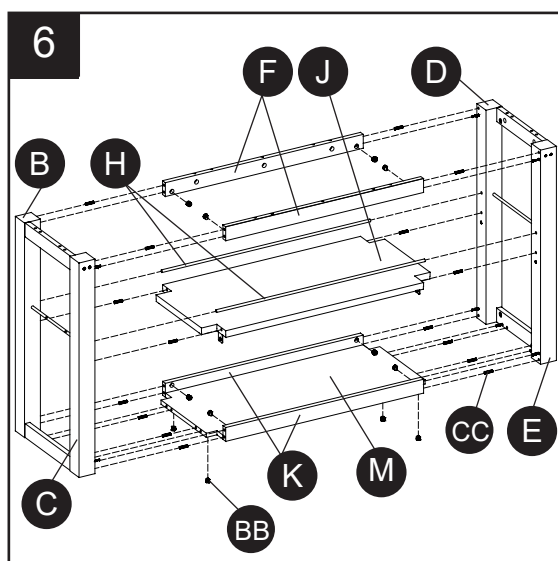
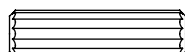

CC Goujon de bois x 16



## INSTRUCTIONS DE MONTAGE

7. Fixer le support arrière gauche (B), le support avant gauche (C), le brancard supérieur (F), le brancard de côté supérieur (G), le support arrière droit (D), le support avant droit (E) au panneau supérieur (A), en utilisant des chevilles en bois (CC) et des verrous à came (BB).

### Quincaillerie utilisée



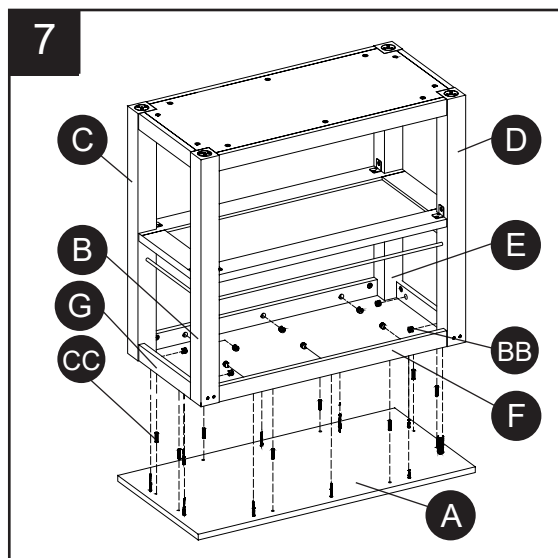

<b>BB</b> Attache Camloc		x 10
<b>CC</b> Goujon de bois		x 8

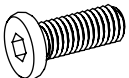

8. Introduire la roulette (O) et la roulette avec frein (P) dans le bas de l'écrou en T du poteau.

A l'aide d'une clé allen (KK), d'un boulons 1/4" x 15 mm (EE), d'une rondelle frein 1/4" (FF), d'une rondelle plate 1/4" (GG), serrer la étagère (J) sur le poteau.

### Quincaillerie utilisée

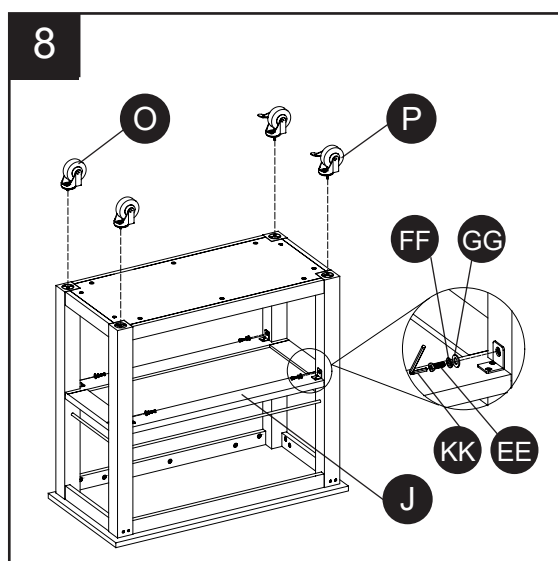

<b>EE</b> Boulon 1/4" x 15mm		x 4
<b>FF</b> 1/4" Rondelle de blocage		x 4
<b>GG</b> 1/4" Rondelle plate		x 4
<b>KK</b> Clé Allen		x 1



9. Serrer la poignée (N) sur le poteau arrière gauche (B), le support avant gauche (C), le support arrière droit (D), le support avant droit (E) à l'aide de la clé allen (KK) et du boulons sala 1/4" x 15 mm (HH).

Tous les trous de fixation de came exposés sont recouverts d'un couvercle en PVC (JJ).

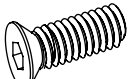
### Quincaillerie utilisée

<b>HH</b> 1/4"x 15 mm Boulons Sala		x 8
<b>JJ</b> Couvercle en PVC		x 26
<b>KK</b> Clé Allen		x 1

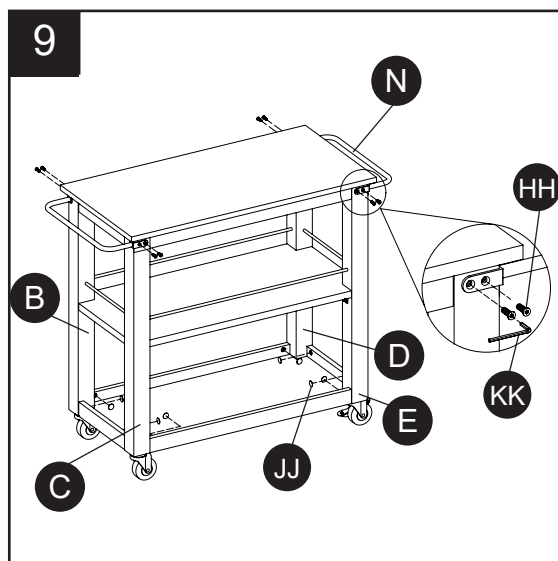

## **SOIN ET ENTRETIEN**

---

- Utiliser un linge doux et propre qui ne rayera pas la surface lors de l'époussetage.
- L'utilisation de poli à meuble n'est pas nécessaire. Le cas échéant, tester d'abord une surface peu visible.
- L'utilisation de solvants de quelque nature que ce soit sur le meuble peut en endommager le fini.
- Ne jamais utiliser d'eau pour nettoyer votre meuble car cela pourrait en endommager le fini.
- Toujours utiliser des sous-verres sous les verres et les pots à fleur.
- Les liquides renversés devraient toujours être retirés sur-le-champ. En utilisant un linge doux et propre, éponger doucement le liquide. Éviter de frotter.
- Toujours utiliser des coussins protecteurs sous les assiettes et les plats chauds. La chaleur peut engendrer des modifications chimiques pouvant créer des taches sur le fini du meuble.
- Les taches et les marques de craies ou de marqueurs à l'encre seront difficiles à retirer.
- Dans le cas où le meuble serait taché ou autrement endommagé lors de l'utilisation, il est recommandé de faire appel à un professionnel pour réparer le meuble.
- Vérifier régulièrement les boulons et les écrous et serrer au besoin.
- Un crayon à retouche (LL) est offert pour réparer toute petite marque ou éraflure pouvant survenir lors du montage ou de l'expédition.

## **GARANTIE LIMITÉE À VIE**

---

Ce produit est garanti à l'acheteur original. En cas de défaut de fabrication ou des matériaux, le fabricant réparera ou remplacera cet article, à sa discrétion, sans frais. La garantie est nulle si le produit a été mal assemblé, utilisé inadéquatement, abusé par la surcharge, modifié de quelque manière que ce soit ou endommagé suite à un accident. La présente garantie n'est pas transférable et ne couvre pas l'écaillage, les éraflures, la rouille, l'enfoncement ni les autres dommages aux surfaces du produit. La responsabilité du fabricant se limite à réparer ou remplacer ce produit. Le fabricant n'est pas responsable des dommages indirects ou accessoires ou de tout autre dommage ou perte résultant d'un bris du produit.

La présente garantie remplace toute autre garantie expresse. Certaines régions ne permettent pas l'exclusion ni la limite des dommages indirects ou accessoires et dans de tels cas, la limite précédente pourrait ne pas s'appliquer. La présente garantie vous donne des recours légaux particuliers et vous pourriez bénéficier d'autres droits qui varient d'une région à l'autre.

## **LISTE DES PIÈCES DE REMPLACEMENT**

---

Pour obtenir des pièces de rechange, communiquez avec notre service à la clientèle au (888) 251-1026, entre 8 h et 20 h (HNE), du lundi au dimanche. Vous pouvez également nous contacter à [partsplus@lowes.com](mailto:partsplus@lowes.com) ou visiter [www.lowespartsplus.com](http://www.lowespartsplus.com).

<b>PIÈCE</b>	<b>DESCRIPTION</b>	<b>N° PIÈCE</b>
A	Panneau supérieur	00LWS35KCR-01
B	Support arrière gauche	00LWS35KCR-02
C	Support avant gauche	00LWS35KCR-03
D	Support arrière droit	00LWS35KCR-04
E	Support avant droit	00LWS35KCR-05
F	Brancard supérieur	00LWS35KCR-06
G	Brancard de côté supérieur	00LWS35KCR-07
H	Brancard métallique long	00LWS35KCC-CR-08
I	Brancard métallique court	00LWS35KCC-CR-09
J	Étagère	00LWS35KCR-10
K	Brancard inférieur	00LWS35KCR-11
L	Brancard de côté inférieure	00LWS35KCR-12
M	Panneau inférieur	00LWS35KCR-13
N	Poignée	00LWS35KCC-CR-14
O	Roulette	00LWS35KCC-CR-15
P	Roulette avec frein	00LWS35KCC-CR-16
AA	Vis Camloc	00LWS35KCC-CR-17
BB	Attache Camloc	00LWS35KCC-CR-18
CC	Goujon de bois	00LWS35KCC-CR-19
DD	Vis M4 x 17 mm	00LWS35KCC-CR-20
EE	Boulon 1/4" x 15 mm	00LWS35KCC-CR-21
FF	1/4" Rondelle de blocage	00LWS35KCC-CR-22
GG	1/4" Rondelle plate	00LWS35KCC-CR-23
HH	1/4"x 15 mm Boulons Sala	00LWS35KCC-CR-24
II	Plaque métallique L	00LWS35KCC-CR-25
JJ	Couvercle en PVC	00LWS35KCC-CR-26
KK	Clé Allen	00LWS35KCC-CR-27
LL	Crayon à retouche	00LWS35KCC-CR-28

# REPLACEMENT PARTS LIST

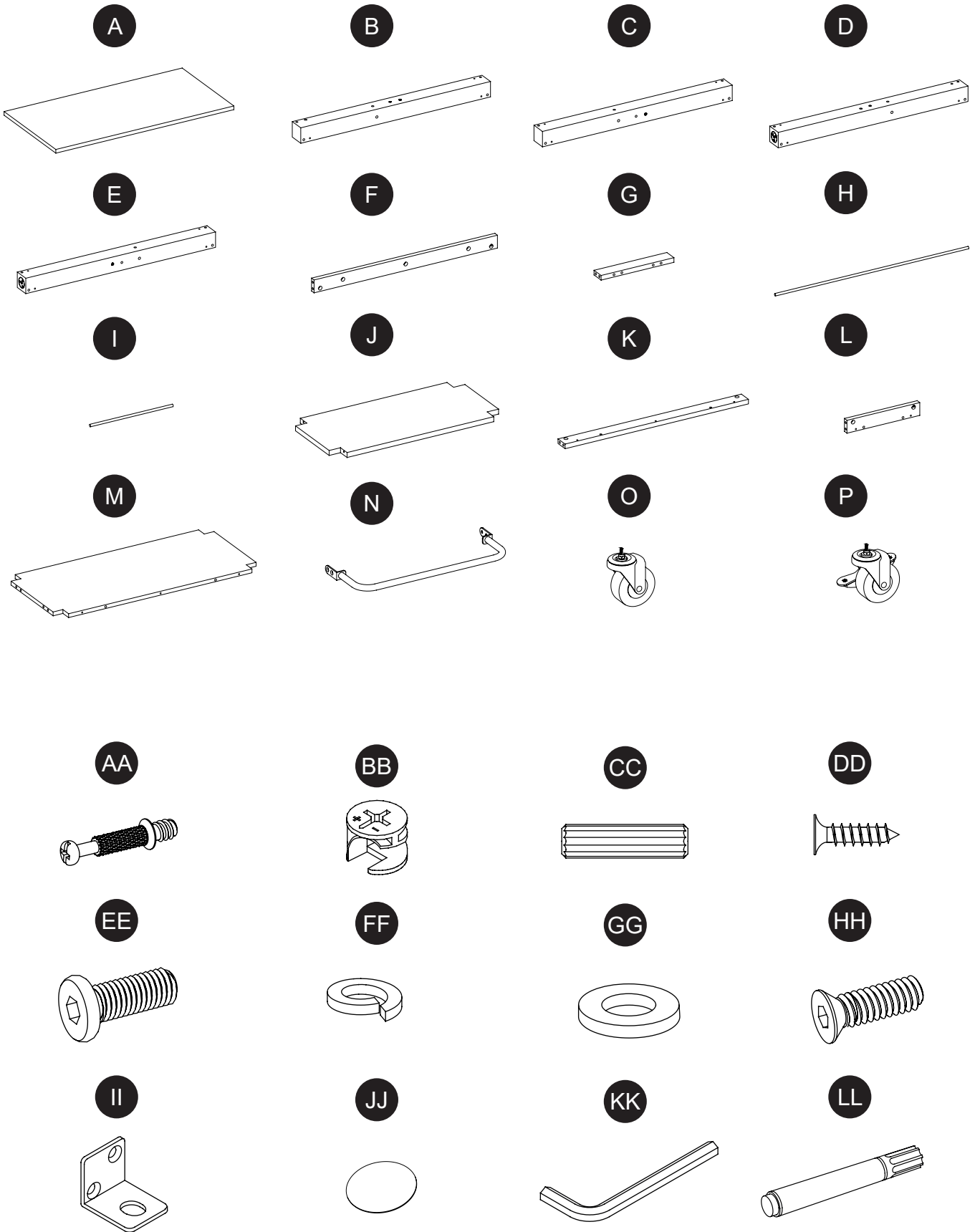

# Origin 21

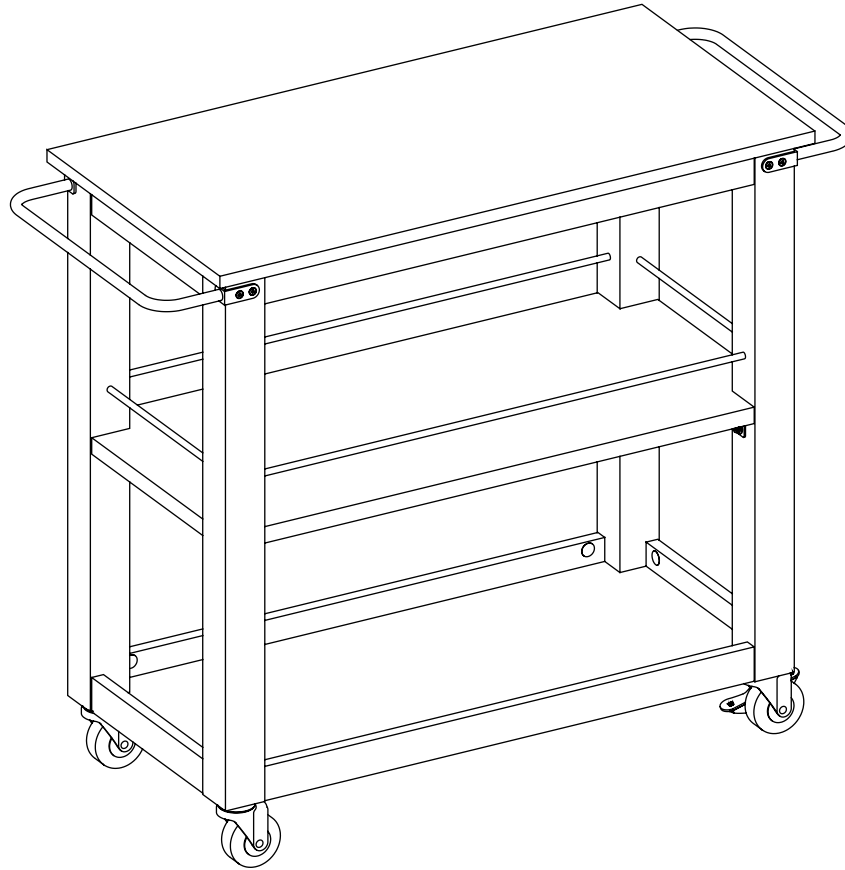

ORIGIN 21 y el diseño del logotipo son marcas comerciales o marcas registradas de LF, LLC. Todos los derechos reservados

ARTÍCULO #4350898

## CARRO DE COCINA CON TAPA DE MADERA DE CAUCHO

MODELO #LWS35KCR

Français p. 12

Español p. 23

ADJUNTAR SU RECIBO AQUÍ

Número de serie \_\_\_\_\_ Fecha de compra \_\_\_\_\_

**¿Preguntas, problemas, piezas faltantes?** Antes de volver a la tienda, llame a nuestro Departamento de Servicio al Cliente al (888) 251-1026, de lunes a domingo de 8 a.m. a 8 p.m., hora estándar del Este. También puedes ponerte en contacto con nosotros en [partsplus@lowes.com](mailto:partsplus@lowes.com).

AS21712

Funcionamiento del sistema de cerrojo de leva.....	24
Contenido del paquete.....	25
Contenido de herraje.....	26
Información de seguridad.....	27
Preparación.....	27
Instrucciones de ensamblaje.....	28
Cuidado y mantenimiento .....	31
Garantía limitada.....	31
Lista de piezas de repuesto .....	32

## FUNCIONAMIENTO DEL SISTEMA DE CERROJO DE LEVA

---

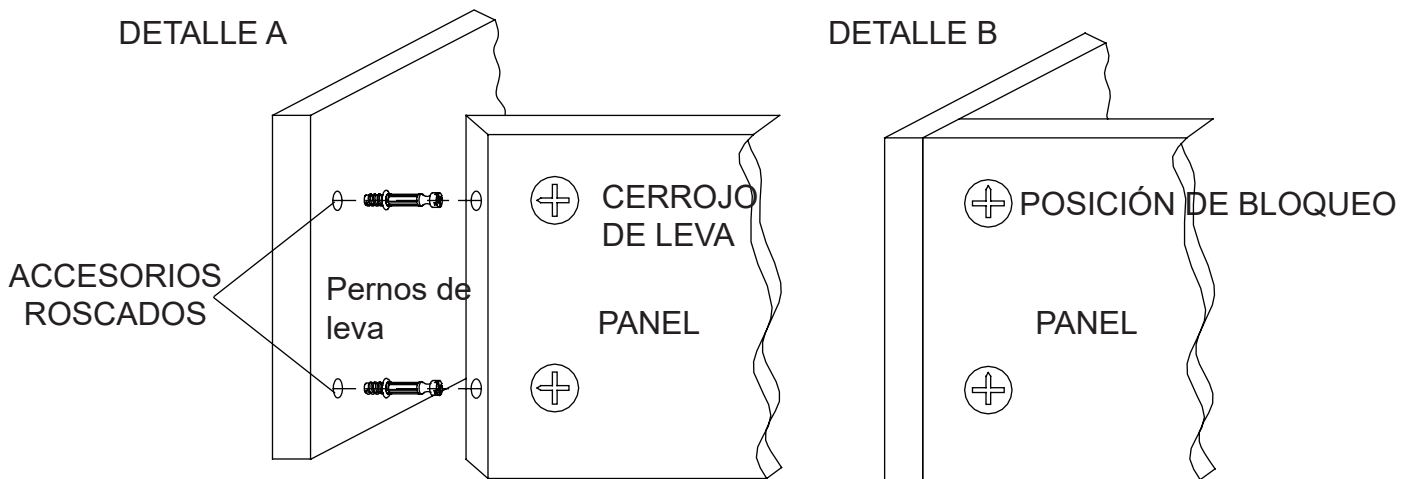

1. Atornille los pernos de leva a los orificios pequeños pretaladrados en el panel.
2. Introduzca el cerrojo de leva al orificio pretaladrado grande en el panel.
3. Asegúrese de que la flecha en el cerrojo de leva señale a los pernos de leva.
4. Una ambos paneles, y asegúrese de que los pernos de leva vayan dentro del orificio pretaladrado en el extremo del panel con cerrojo de leva.
5. Una vez que los pernos de leva estén conectados dentro del cerrojo de leva, tome el destornillador Phillips y apriete el cerrojo de leva en dirección de las manecillas del reloj.



## CONTENIDO DEL PAQUETE

PARTE	DESCRIPCIÓN	CANTIDAD	PARTE	DESCRIPCIÓN	CANTIDAD
A	Panel superior	1	I	Camilla metálica corta	2
B	Poste trasero izquierdo	1	J	Estantería	1
C	Poste delantero izquierdo	1	K	Camilla inferior	2
D	Poste trasero derecho	1	L	Camilla lateral inferior	2
E	Poste delantero derecho	1	M	Panel inferior	1
F	Camilla superior	2	N	Manija	2
G	Camilla lateral superior	2	O	Rueda	2
H	Camilla metálica larga	2	P	Rueda con freno	2

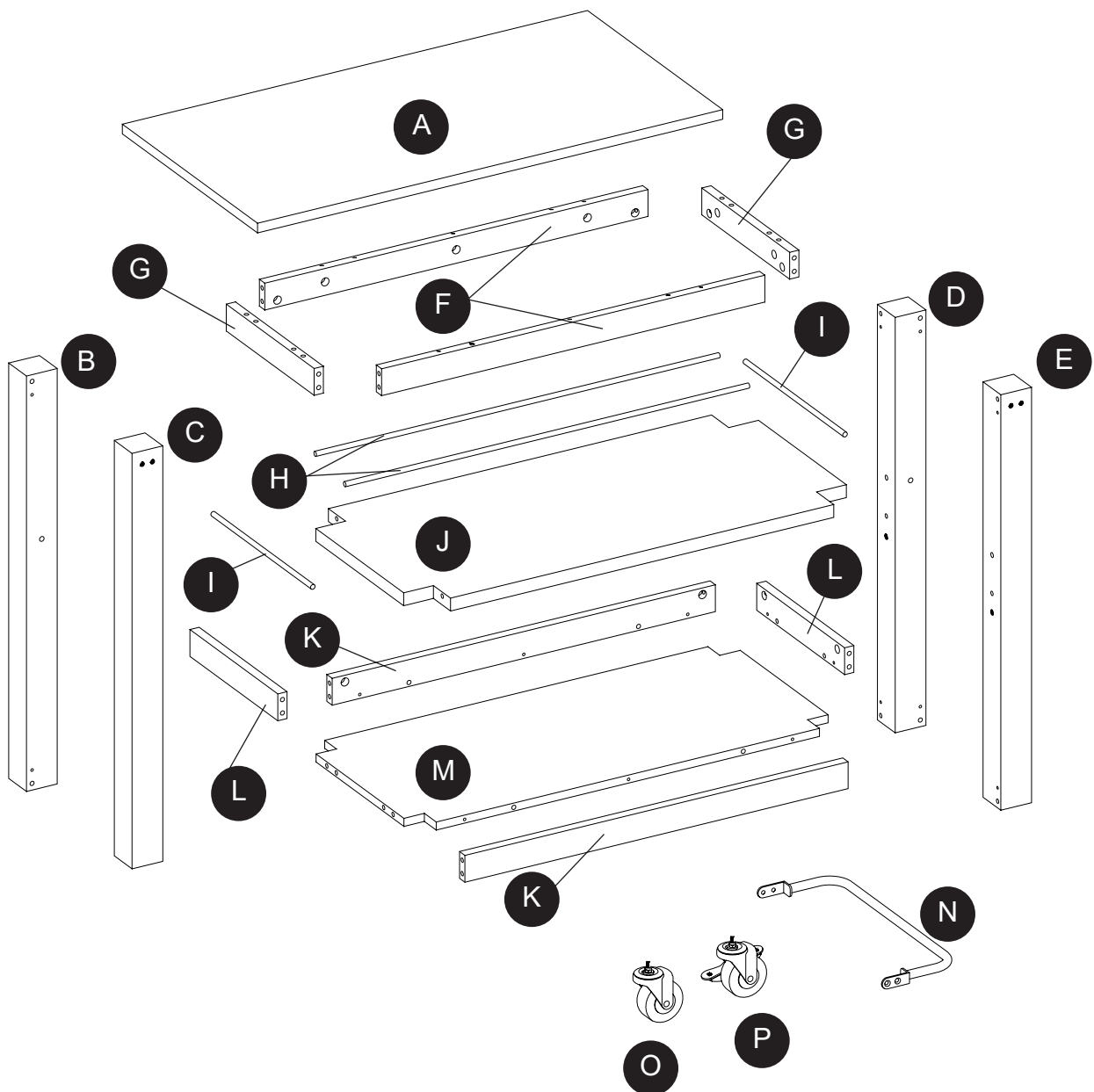

**CONTENIDO DE HERRAJE (no se muestran en tamaño real)**

---

AA



Perno de leva

Cant. 36

BB



Cerrojo de leva

Cant. 36

CC

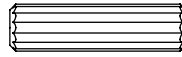

Espiga de madera

Cant. 36

DD

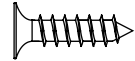

Tornillo  
M4 x 17 mm  
Cant. 8

EE

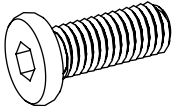

Perno de  
1/4" x 15 mm  
Cant. 4

FF

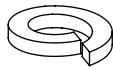

1/4" Arandela de  
seguridad  
Cant. 4

GG

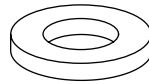

1/4" Arandela  
plana  
Cant. 4

HH

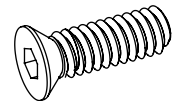

perno de sala  
1/4" x 15 mm  
Cant. 8

II

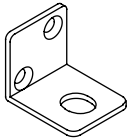

Placa metálica en  
forma de L  
Cant. 4

JJ

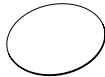

Cubierta de PVC  
Cant. 26

KK

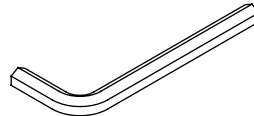

Llave hexagonal  
Cant. 1

LL

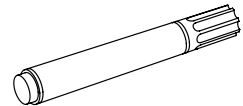

Plumón de retoque  
Cant. 1

## **! INFORMACIÓN DE SEGURIDAD**

Por favor lea y comprenda el manual entero antes de intentar ensamblar o instalar el producto.

1. Por favor, lea las instrucciones de ensamble antes de usar la unidad.
2. Para evitar daños, ensamble la unidad sobre una superficie firme, nivelada y no abrasiva.
3. Mantenga todos los accesorios y las piezas fuera del alcance de los niños
4. Espere hasta que se completen todos los pasos antes de apretar completamente los tornillos.
5. Asegúrese de que todos los pernos y tornillos estén bien apretados antes de utilizar la unidad.
6. Verifique que todos los pernos, tornillos estén apretados por lo menos cada 3 meses o cuando sea necesario.

## **! ADVERTENCIA**

ESTÁ UNIDAD ESTA DISEÑADA PARA USO UNICAMENTE CON LOS PESOS MÁXIMOS INDICADOS. USO CON CARGAS MAYORES DE LOS PESOS MÁXIMOS INDICADOS PUEDE RESULTAR EN INESTABILIDAD, CAUSANDO POSIBLES LESIONES.

CAPACIDAD MÁXIMA DE  
LA PANEL SUPERIOR:  
45.4 kg / 100 lb  
DISTRIBUIDOS  
UNIFORMEMENTE.

CAPACIDAD MÁXIMA DE  
LA REPISA:  
13.6 kg / 30 lb  
DISTRIBUIDOS  
UNIFORMEMENTE.

CAPACIDAD MÁXIMA DE LA  
UNIDAD COMPLETA:  
72.7 kg / 160 lb  
DISTRIBUIDOS  
UNIFORMEMENTE

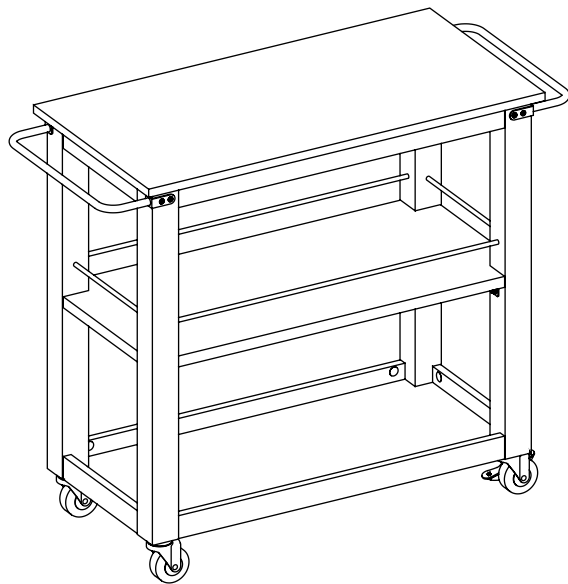

## **PREPARACIÓN**

Antes de empezar el ensamble del producto, asegúrese de que todas las partes estén presentes. Compare las piezas con el contenido en la lista de partes del paquete y el diagrama de arriba. Si alguna parte falta o está dañada, no intente ensamblar el producto. Póngase en contacto con servicio al cliente para las piezas de reemplazo.

**Tiempo estimado de ensamble: 60 minutos.**

Herramienta requerida para el ensamble: destornillador phillips, detector de vigas, lápiz para marcar, cinta métrica, taladro eléctrico, broca.

## INSTRUCCIONES DE ENSAMBLAJE

1. Inserte los pernos de leva (AA) en el poste trasero izquierdo (B), el poste delantero izquierdo (C), el poste trasero derecho (D), el poste delantero derecho (E), la camilla inferior (K) y la camilla lateral inferior (L).

### Herraje Utilizado

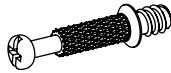
AA Perno de leva  x 26

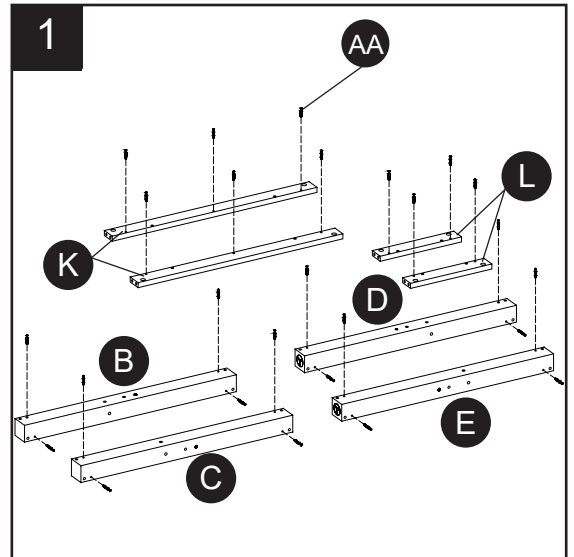

2. Fije la camilla inferior (K) al panel inferior (M) utilizando pasadores de madera (CC) y cierres de leva (BB).

### Herraje Utilizado

BB Cerrojo de leva  x 6

CC Espiga de madera  x 4

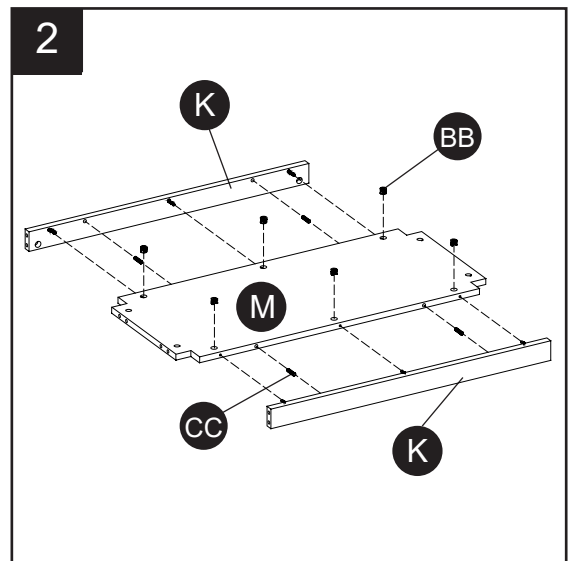

3. Fije el poste trasero izquierdo (B), la camilla lateral superior (G), la camilla metálico corto (I) y la camilla lateral inferior (L) al poste delantero izquierdo (C). Fije el poste trasero derecho (D), la camilla lateral superior (G), la camilla metálico corto (I) y la camilla lateral inferior (L) al poste delantero derecho (E), utilizando pasadores de madera (CC) y cierres de leva (BB).

### Herraje Utilizado

BB Cerrojo de leva  x 8

CC Espiga de madera  x 8

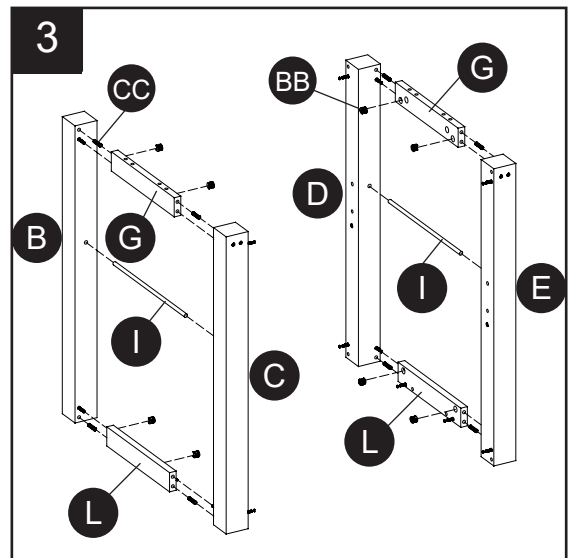

## INSTRUCCIONES DE ENSAMBLAJE

4. Inserte los pernos de la leva (AA) en el panel superior (A).

### Herraje Utilizado

AA Perno de leva x 10

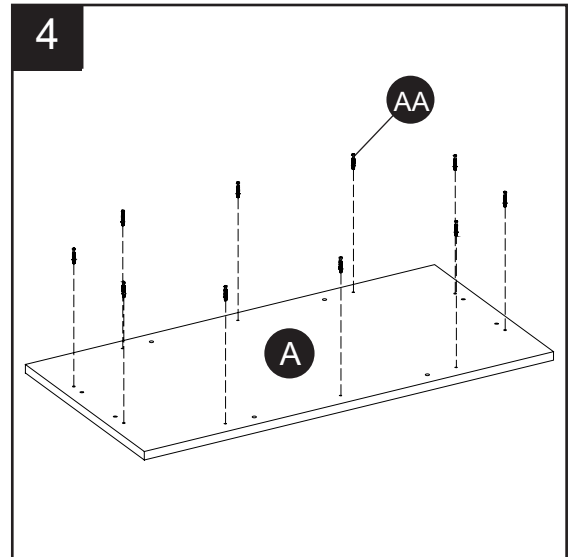
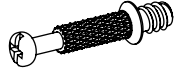

5. Instale la placa metálica en forma de L (II) en el orificio piloto del estante (J), apriete con los tornillos (DD).

### Herraje Utilizado

DD Tornillo M4 x 17 mm x 8

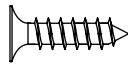

II Placa metálica en forma de L x 4

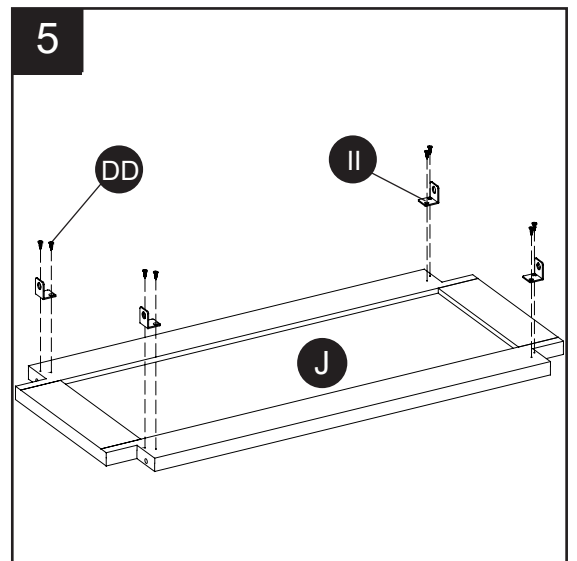
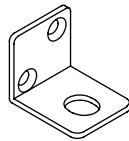

6. Fije el poste trasero izquierdo (B), el poste delantero izquierdo (C), la camilla superior (F), la camilla metálica larga (H), el estante (J) y la camilla inferior (K), panel inferior (M) al poste trasero derecho (D) y al poste delantero derecho (E), utilizando pasadores de madera (CC) y cierres de leva (BB).

### Herraje Utilizado

BB Cerrojo de leva x 12



CC Espiga de madera x 16

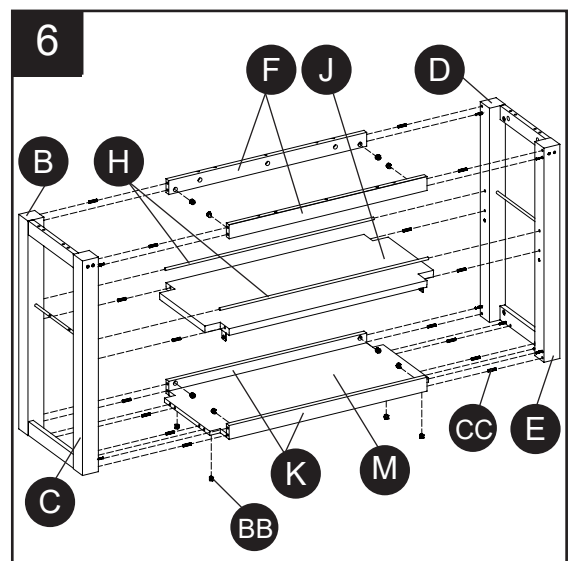
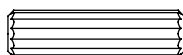

## INSTRUCCIONES DE ENSAMBLAJE

7. Fije el poste trasero izquierdo (B), el poste delantero izquierdo (C), la camilla superior (F), la camilla lateral superior (G), el poste trasero derecho (D), el poste delantero derecho (E) al panel superior (A), utilizando pasadores de madera (CC) y cierres de leva (BB).

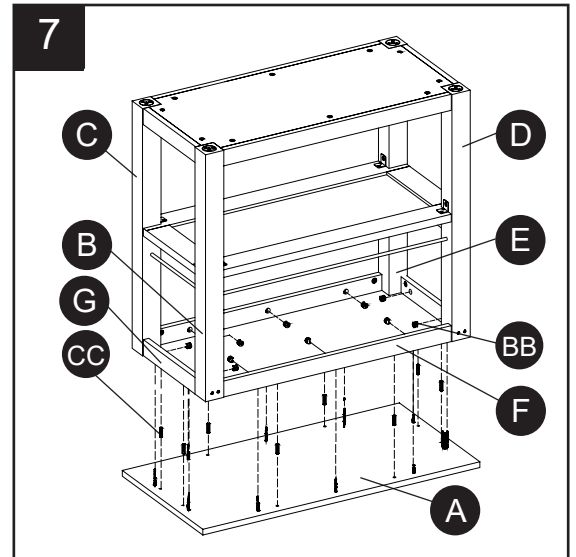



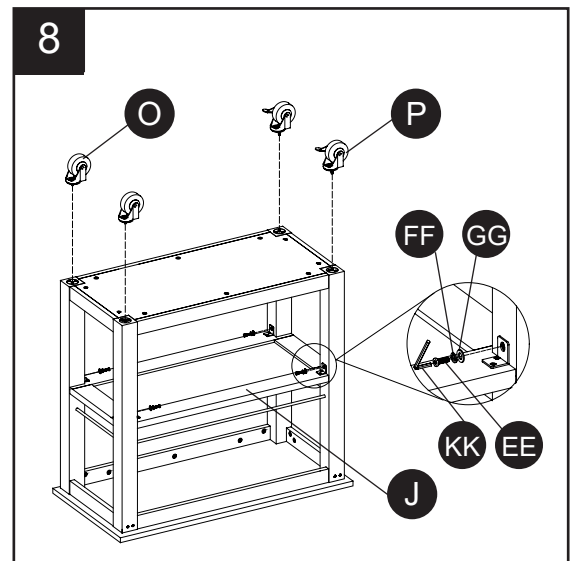

### Herraje Utilizado

<b>BB</b> Cerrojo de leva		x 10
<b>CC</b> Espiga de madera		x 8

8. Instale la rueda (O) y la rueda con freno (P) en la parte inferior de la tuerca T del poste. Utilizando la llave hexagonal (KK), el perno de 1/4" x 15 mm (EE), la arandela de seguridad de 1/4" (FF) y la arandela plana de 1/4" (GG), apriete el estante (J) en el poste.

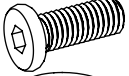



### Herraje Utilizado

<b>EE</b> Perno de 1/4"x 15 mm		x 4
<b>FF</b> 1/4" Arandela de seguridad		x 4
<b>GG</b> 1/4" Arandela plana		x 4
<b>KK</b> Llave hexagonal		x 1

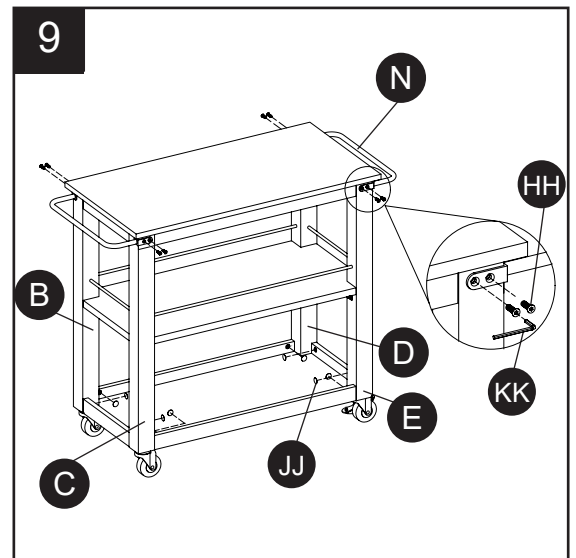
9. Usando la llave hexagonal (KK) y el perno de sala de 1/4" x 15 mm (HH), apriete la manija (N) en el poste trasero izquierdo (B), el poste delantero izquierdo (C), el poste trasero derecho (D) y el poste delantero derecho (E). Todos los agujeros de cierre de leva expuestos están cubiertos con una cubierta de PVC (JJ).

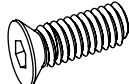

### Herraje Utilizado

<b>HH</b> perno de sala 1/4"x 15 mm		x 8
<b>JJ</b> Cubierta de PVC		x 26
<b>KK</b> Llave hexagonal		x 1

## **CUIDADO Y MANTENIMIENTO**

---

- Utilice un paño suave y limpio para que no se raye la superficie cuando limpie el polvo
- El uso de ceras para muebles no es necesario. Si decide utilizar ceras, checar un área poco visible.
- Uso de disolventes de cualquier tipo en sus muebles puede dañar el terminado.
- Nunca utilice agua para limpiar sus muebles, ya que puede causar daños al terminado.
- Utilice siempre toallas bajo vasos de bebidas.
- Los derrames de líquidos deben ser retirados inmediatamente. Con un paño suave y limpio, seque el derrame suavemente. Evitar frotar.
- Siempre use almohadillas protectoras en platos calientes. El calor puede causar cambios químicos que pueden crear manchas en los muebles.
- Las manchas o marcas de crayones o marcadores de tinta difícil para eliminar.
- En el caso de que sus muebles se tiñe o dañado durante el uso, se recomienda que de llamar a un profesional para reparar sus muebles.
- Revise los tornillos/tuercas periódicamente y apretar si es necesario.
- Plumón de retoque (LL) se ha proporcionado para reparar los pequeños rasguños o arañazos que pueden ocurrir durante montaje o envío.

## **GARANTIA LIMITADA**

---

Este producto (con exclusión de las repisas) está garantizado para el comprador original. Si hay un fallo en esta unidad debido a defectos en los materiales o mano de obra, el fabricante reparará o reemplazará esta unidad a nuestra discreción y sin cargo alguno. La garantía queda anulada si el producto ha sido ensamblado incorrectamente, utilizado incorrectamente por la sobrecarga, de alguna forma alterada o dañada debido a un accidente. Esta garantía no es transferible y no cubre astillado, descamación, arañazos, óxido, abolladuras u otros daños a las superficies de este producto. La responsabilidad del fabricante se limita a la reparación o sustitución de este producto. El fabricante no es responsable de daños consecuentes, incidentales o de otra, o pérdidas resultantes de la falla del producto.

Esta garantía está en lugar de cualquier otra garantía expresa. Algunos estados no permiten la exclusión o limitación de daños incidentales o consecuentes, por lo que la limitación anterior puede no ser aplicable en su caso. Esta garantía le otorga derechos legales específicos y usted puede tener otros derechos que varían de estado a estado.

## LISTA DE PIEZAS DE REPUESTO

Para obtener piezas de repuesto, llame a nuestro Departamento de Servicio al Cliente al (888) 251-1026, de lunes a domingo de 8 a.m. a 8 p.m., hora estándar del Este. También puedes ponerte en contacto con nosotros en [partsplus@lowes.com](mailto:partsplus@lowes.com) o visitar [www.lowespartsplus.com](http://www.lowespartsplus.com).

PIEZA	DESCRIPCIÓN	PIEZA #
A	Panel superior	00LWS35KCR-01
B	Poste trasero izquierdo	00LWS35KCR-02
C	Poste delantero izquierdo	00LWS35KCR-03
D	Poste trasero derecho	00LWS35KCR-04
E	Poste delantero derecho	00LWS35KCR-05
F	Camilla superior	00LWS35KCR-06
G	Camilla lateral superior	00LWS35KCR-07
H	Camilla metálica larga	00LWS35KCC-CR-08
I	Camilla metálica corta	00LWS35KCC-CR-09
J	Estantería	00LWS35KCR-10
K	Camilla inferior	00LWS35KCR-11
L	Camilla lateral inferior	00LWS35KCR-12
M	Panel inferior	00LWS35KCR-13
N	Manija	00LWS35KCC-CR-14
O	Rueda	00LWS35KCC-CR-15
P	Rueda con freno	00LWS35KCC-CR-16
AA	Perno de leva	00LWS35KCC-CR-17
BB	Cerrojo de leva	00LWS35KCC-CR-18
CC	Espiga de madera	00LWS35KCC-CR-19
DD	Tornillo M4 x 17 mm	00LWS35KCC-CR-20
EE	Perno de 1/4" x 15 mm	00LWS35KCC-CR-21
FF	1/4" Arandela de seguridad	00LWS35KCC-CR-22
GG	1/4" Arandela plana	00LWS35KCC-CR-23
HH	perno de sala 1/4"x 15 mm	00LWS35KCC-CR-24
II	Placa metálica en forma de L	00LWS35KCC-CR-25
JJ	Cubierta de PVC	00LWS35KCC-CR-26
KK	Llave hexagonal	00LWS35KCC-CR-27
LL	Plumón de retoque	00LWS35KCC-CR-28



**LISTA DE PIEZAS DE REPUESTO**

