

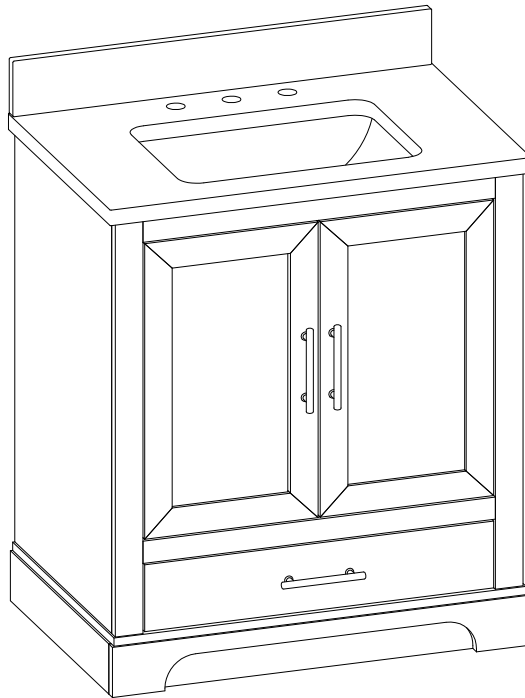

Item #358060
Model # HDC30PRGV

USE AND CARE GUIDE

30" VANITY



Questions, problems, missing parts? Before returning to the store,
call Glacier Bay Customer Service
8 a.m. - 7 p.m., EST, Monday - Friday, 9 a.m. - 6 p.m., EST, Saturday

1-855-HD-GLACIER

HOMEDEPOT.COM/GLACIERBAY

THANK YOU

We appreciate the trust and confidence you have placed in Glacier Bay through the purchase of this wall mount vanity with shelf mirror. We strive to continually create quality products designed to enhance your home. Visit us online to see our full line of products available for your home improvement needs. Thank you for choosing Glacier Bay!

Table of Contents

Table of Contents	2	Hardware Included	4
Safety Information.....	2	Package Contents	5
Limited Lifetime Warranty	2	Installation	6
Minnesota Residents	3	Care and Cleaning	8
Pre-installation	4	Maintenance	8
Planning Installation	4	Service Parts	9
Tools required	4		

Safety Information

- Please read and understand these instructions before assembling and using this product. Save these instructions for future reference.



WARNING: Do not stand on the vanity. Use the vanity on level ground. The base vanity supports a maximum weight of 200 lbs. Exceeding the maximum weight limits will compromise the integrity of the vanity structure and could cause the vanity to fail.

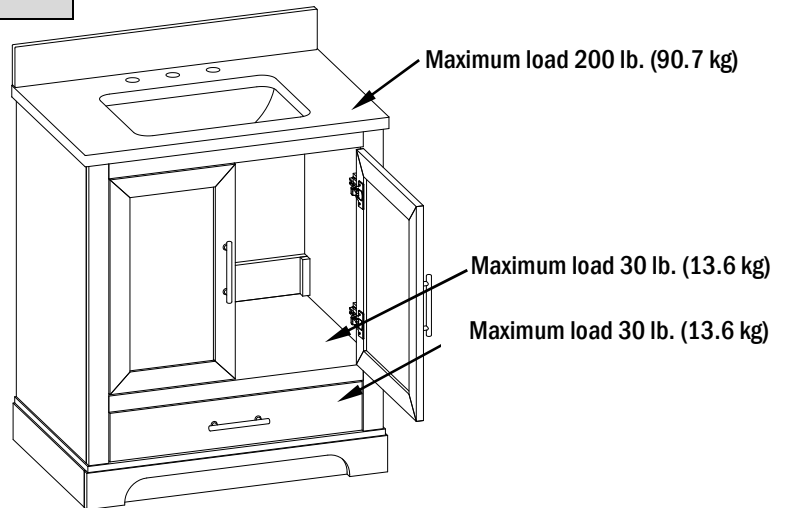

Limited Lifetime Warranty

This product is warranted to the original purchaser. If there is a failure in this unit due to defects in materials or workmanship, the manufacturer will repair or replace this item at our discretion without charge. Warranty is void if product has been assembled incorrectly, misused, abused by overloading, altered in any way or damaged due to accident. This warranty is not transferable and does not cover chipping, flaking, scratches, rust, dents, or other damages to the surfaces of this product. Responsibility of the manufacturer is limited to repair or replacement of this product. The manufacturer is not responsible for consequential, incidental, or other damages or losses resulting from product failure. This warranty is in lieu of all other expressed warranties. Some states do not allow the exclusion or limitation of incidental or consequential damages, so the above limitation may not apply to you. This warranty gives you specific legal rights and you may have other rights which vary from state to state.

Contact the Customer Service Team at 1-855-HD-GLACIER or visit www.HomeDepot.com/GlacierBay.

Minnesota Residents

MINNESOTA RESIDENTS

"IMPORTANT HEALTH NOTICE.

SOME OF THE BUILDING MATERIALS USED IN THIS HOME (OR THESE BUILDING MATERIALS) EMIT FORMALDEHYDE. EYE, NOSE, AND THROAT IRRITATION, HEADACHE, NAUSEA AND A VARIETY OF ASTHMA-LIKE SYMPTOMS, INCLUDING SHORTNESS OF BREATH, HAVE BEEN REPORTED AS A RESULT OF FORMALDEHYDE EXPOSURE. ELDERLY PERSONS AND YOUNG CHILDREN, AS WELL AS ANYONE WITH A HISTORY OF ASTHMA, ALLERGIES, OR LUNG PROBLEMS, MAY BE AT GREATER RISK. RESEARCH IS CONTINUING ON THE POSSIBLE LONG-TERM EFFECTS OF EXPOSURE TO FORMALDEHYDE.

REDUCED VENTILATION MAY ALLOW FORMALDEHYDE AND OTHER CONTAMINANTS TO ACCUMULATE IN THE INDOOR AIR. HIGH INDOOR TEMPERATURES AND HUMIDITY RAISE FORMALDEHYDE LEVELS. WHEN A HOME IS TO BE LOCATED IN AREAS SUBJECT TO EXTREME SUMMER TEMPERATURES, AN AIR-CONDITIONING SYSTEM CAN BE USED TO CONTROL INDOOR TEMPERATURE LEVELS. OTHER MEANS OF CONTROLLED MECHANICAL VENTILATION CAN BE USED TO REDUCE LEVELS OF FORMALDEHYDE AND OTHER INDOOR AIR CONTAMINANTS.

IF YOU HAVE ANY QUESTIONS REGARDING THE HEALTH EFFECTS OF FORMALDEHYDE, CONSULT YOUR DOCTOR OR LOCAL HEALTH DEPARTMENT."

Pre-installation

PLANNING INSTALLATION

Compare all parts with the Hardware Included and Package Contents list. If any part appears missing or damaged, do not assemble this product and contact the Customer Service Team at 1-855-HD-GLACIER or visit www.HomeDepot.com/GlacierBay.

TOOLS REQUIRED



Phillips
screwdriver

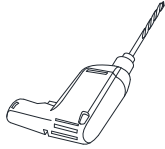

Drill

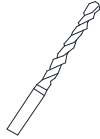

Bit



Silicone
compound

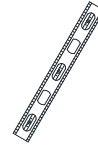

Level

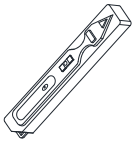

Stud finder

HARDWARE INCLUDED



NOTE: Hardware not shown to actual size.



— AA

Part	Description	Quantity
AA	Touch-up Pen	1

Pre-installation (continued)

PACKAGE CONTENTS

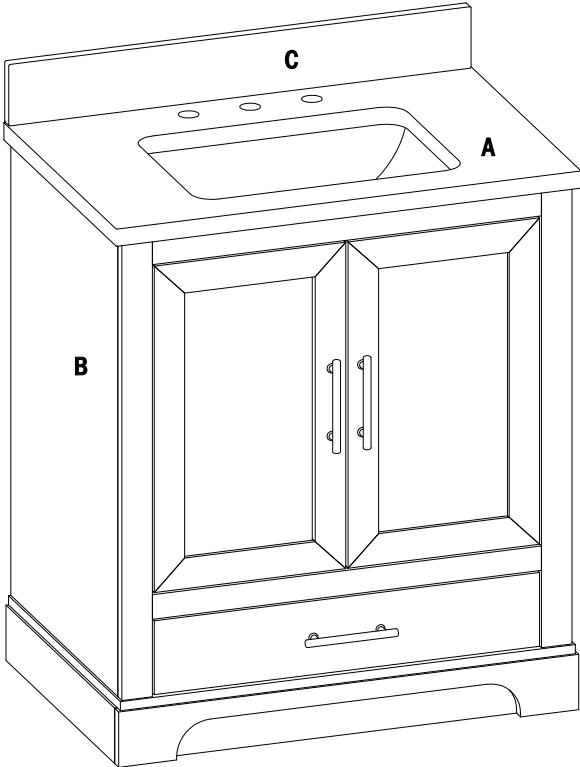

Part	Description	Quantity
A	Vanity Top	1
B	Vanity Base	1
C	Backsplash	1

Installation

1 Water Supply Lines and Drain Installation Guide

- Mark wall for vanity placement and note the location of the water supply lines and drain on the back panel of vanity.
- Move vanity (B) into proper place against the wall.
- Install faucet, drain and supply lines (none included) to vanity top (A) according to the instructions supplied with those items.

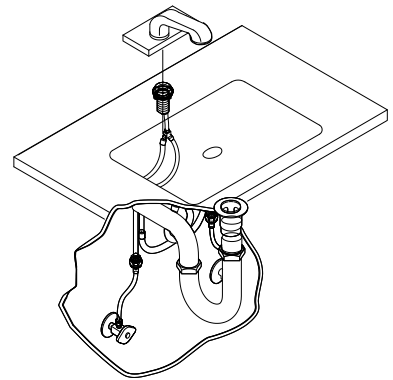
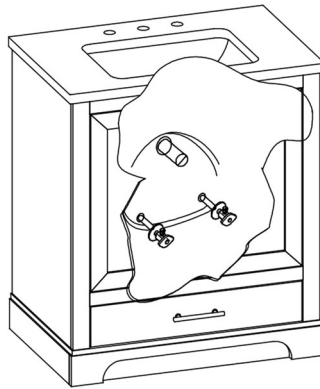
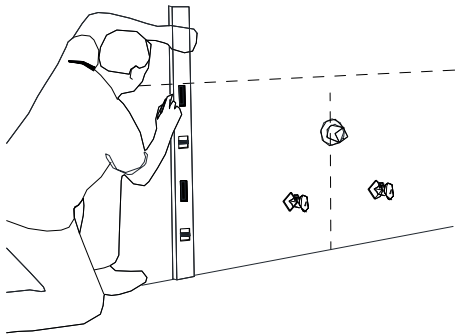

2 Backsplash Installation

- To mount the backsplash (C) to the wall, apply a thin bead of silicone compound (not included) to the unpolished back side and bottom of the backsplash (C). Position backsplash (C) as shown onto vanity top (A) and against the wall. Clean any excess silicone compound before allowing to dry.

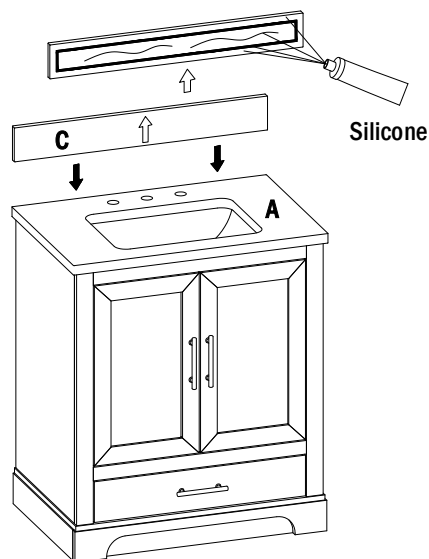

Installation (continued)

3 Vanity Drawer Removal

□ Removing the Drawer:

1. Unload the contents from the drawer.
2. Slide out the drawer as far as it will go.
3. Press the lever down on the right-hand track and lift the lever up on the left track to release the drawer. Pull the drawer out the rest of the way.

□ Replacing the Drawer

1. Align the drawer guides with the receiving glides.
2. Hold the receiving glides firmly and insert the drawer guide.

NOTE: It is normal for the drawer to close tightly the first time after it has been removed.

3. Push the drawer in completely.

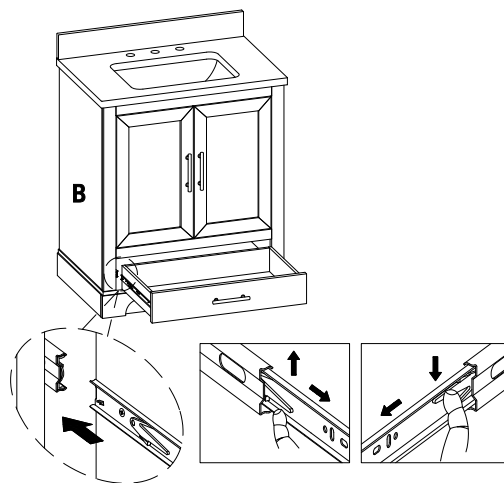

4 Hinge Adjustment For Door Alignment

□ If the doors preassembled to vanity base (B) require adjustment, follow the below options as needed:

- To adjust door up or down, loosen screws (a), adjust door and retighten screws.
- To adjust door left and right, turn screw (b) in or out.
- To adjust door in and out, loosen screw (c), adjust door and retighten screw.

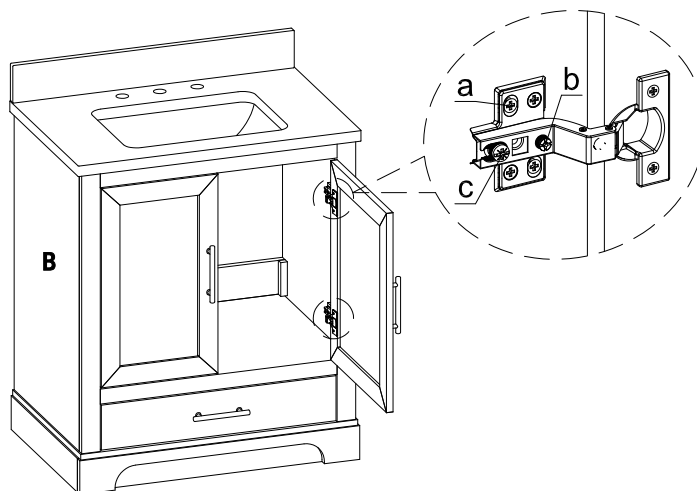

Care and Cleaning

- Use a soft, clean cloth that will not scratch the surface when dusting.
- Use of furniture polishes is not necessary. Should you choose to use polishes, test the polish in an inconspicuous area before using over the entire surface of the product.
- Using solvents of any kind on your furniture may damage the finish.
- Never use water to clean your furniture as it may cause damage to the finish.
- Always use coasters under beverage glasses and flowerpots.
- Liquid spills should be removed immediately. Using a soft, clean cloth, blot the spill gently. Avoid rubbing.
- Always use protective pads under hot dishes and plates. Heat can cause chemical changes that may create spotting within the furniture finish.
- Use care as stains or marks from crayons or ink markers will be difficult to remove.
- Be sure to immediately clean red wine or soda stains within 30 minutes or the surface will stain.

Maintenance

- In the event that your furniture is stained or otherwise damaged during use, we recommend that you call a professional to repair your furniture.
- Check bolts/screws periodically and tighten them if necessary.
- A touch-up pen (AA) has been provided to repair any small nicks or scratches that may occur during assembly or shipping.

Service Parts

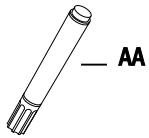
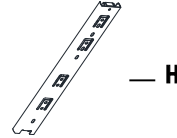
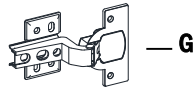
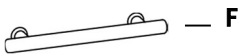
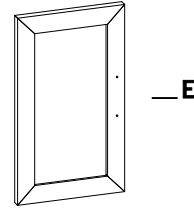
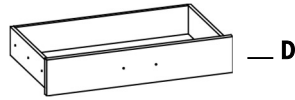

Part	Description	Quantity
C	Backsplash	1
D	Drawer	1
E	Door	2
F	Handle with Bolt	3
G	Slow Close Hinge	4
H	Drawer Slides	2
AA	Touch-up Pen	1



Questions, problems, missing parts? Before returning to the store,
call Glacier Bay Customer Service
8 a.m. – 7 p.m., EST, Monday-Friday, 9 a.m. – 6 p.m., EST, Saturday

1-855-HD-GLACIER

[HOMEDEPOT.COM/GLACIERBAY](https://www.homedepot.com/glacierbay)

Retain this manual for future use.