



THRESHOLDTM_{MC}

Cambridge Turned Leg Desk Off White

Style # T71113-4A

DPC-item #: 249-14-5144 / 249-94-0067

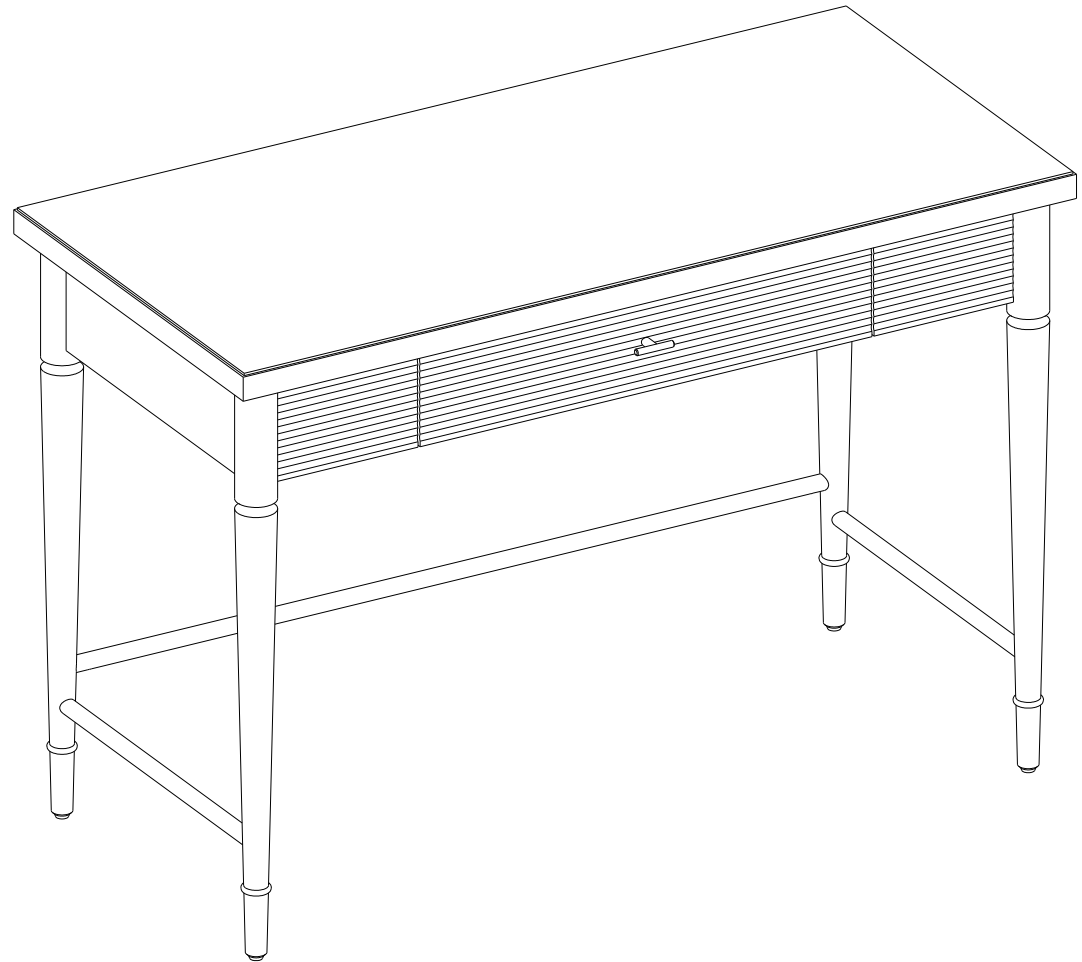

>> Assembly instructions



Congratulations on your latest Target purchase.

Now what? Don't start sweating over this box of parts. This will be easy. We did the hard work for you. All you need to do is follow our simple instructions and you'll be on your way to transforming your room in no time. Good luck – though we're confident you won't need it.

before you begin

1. Check for damaged or missing parts. Call 1-855-MYTGTHOME (855-698-4846) to order missing supplies.
2. Use the carton as a work surface to prevent product damage during assembly.
3. Gather all tools prior to assembly.

tools needed (not included)

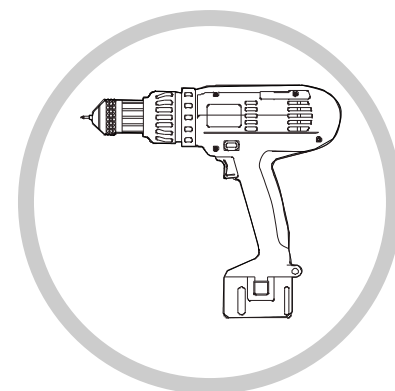
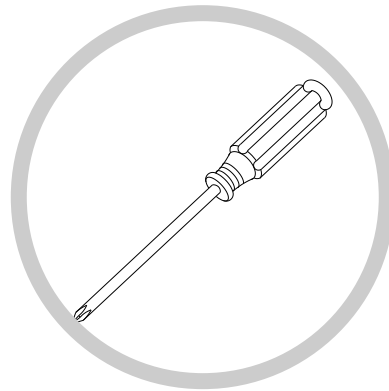
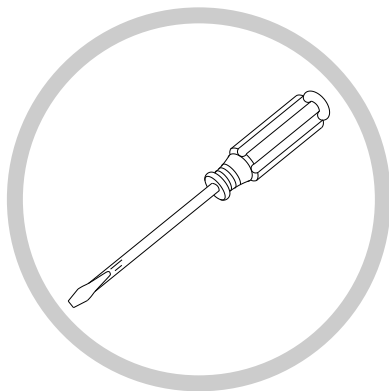
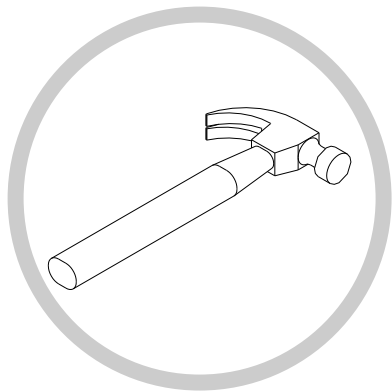

For tipping restraint hardware kit only

table of contents

| | |
|-----------------------------------|------|
| Introduction | 2 |
| Hardware | 4 |
| Parts list | 5 |
| Assembly | 6-10 |
| Care and maintenance and warranty | 11 |
| Important safety information | 12 |

| ⚠ WARNING | |
|--|---|
|  | <p>Serious or fatal crushing injuries can occur from furniture tip-over. To help prevent tip-over:</p> <ul style="list-style-type: none">• Install tip-over restraint provided.• Place heaviest items in the lowest drawers.• Do not set TV's or other heavy objects on top of this product, unless the product is specifically designed to accommodate them.• Never allow children to climb or hang on drawers, doors, or shelves.• Never open more than one drawer at a time. <p>Use of tip-over restraints may only reduce, but not eliminate, the risk of tip-over.</p> <p><i>This is a permanent label. Do not remove!</i></p> |

hardware

(H1) x 8
2 1/2" bolt

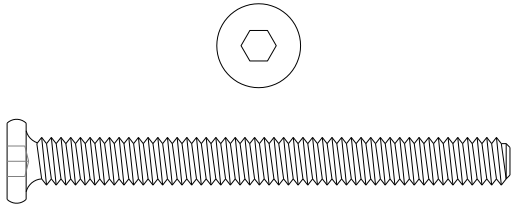

(H2) x 8
lock washer



(H3) x 8
flat washer

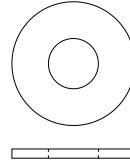

(H4) x 6
1 1/2" screw

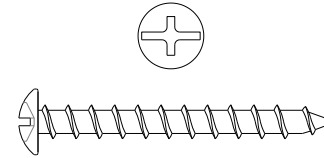

(H5) x 1
hex wrench



(H6) x 2
tipping restraint hardware kit
(inside plastic bag)

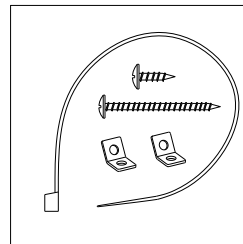

Spare hardware

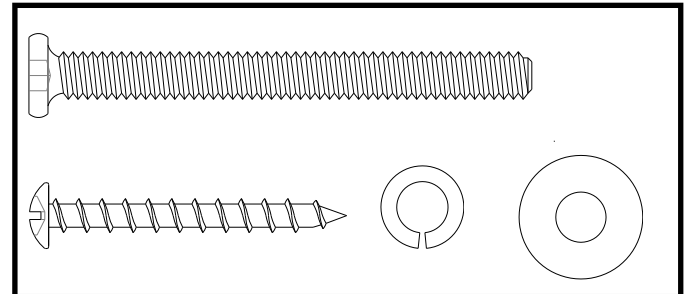

| ITEM | DESCRIPTION | QUANTITY |
|------|-------------|----------|
|------|-------------|----------|

| | | |
|---|-----------------|---|
| A | Desk top | 1 |
| B | Left front leg | 1 |
| C | Right front leg | 1 |
| D | Left back leg | 1 |
| E | Right back leg | 1 |
| F | Back stretcher | 1 |
| G | Side stretcher | 2 |

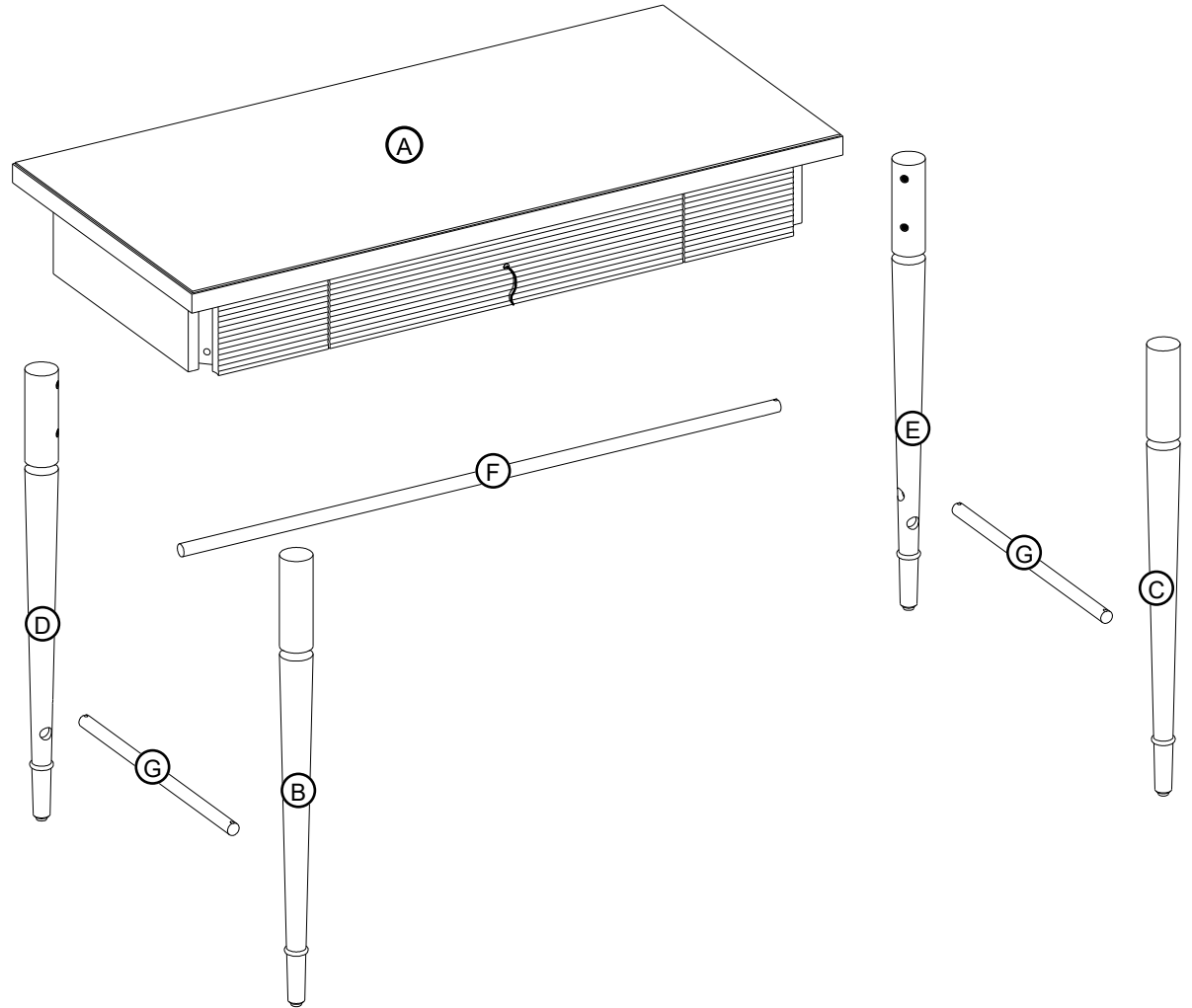

step 1.

NOTE: DO NOT fully tighten all bolts until you finish assembling all parts. Once assembled, go back and fully tighten all bolts. This will make the assembly easier.

(H1) x 4
2 1/2" bolt

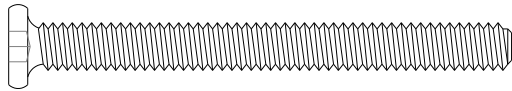

(H3) x 4
flat washer

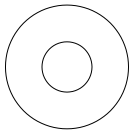

(H2) x 4
lock washer



(H5) x 1
hex wrench

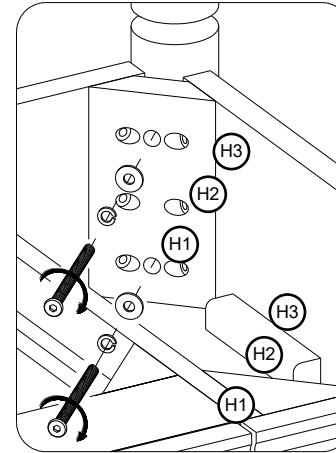

The slant holes will face the floor when the unit is turned upright

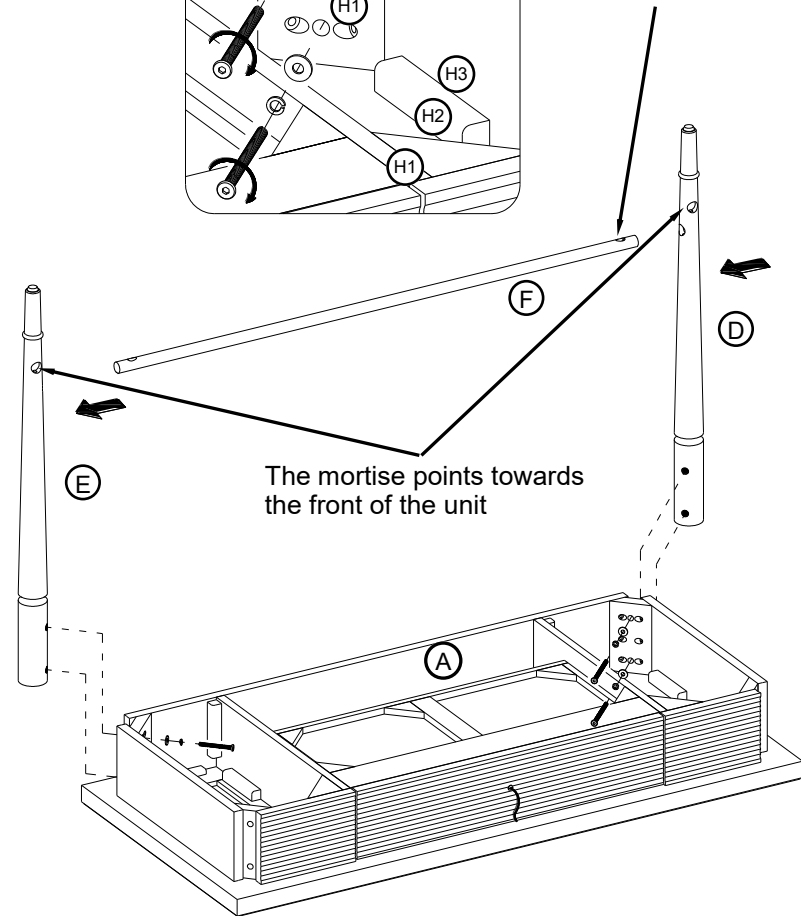

Fit the back stretcher (F) between the back legs (D and E) and attach them to the back apron of desk top (A).

step 2.

NOTE: DO NOT fully tighten all bolts until you finish assembling all parts. Once assembled, go back and fully tighten all bolts. This will make the assembly easier.

The slant holes will face the floor when the unit is turned upright

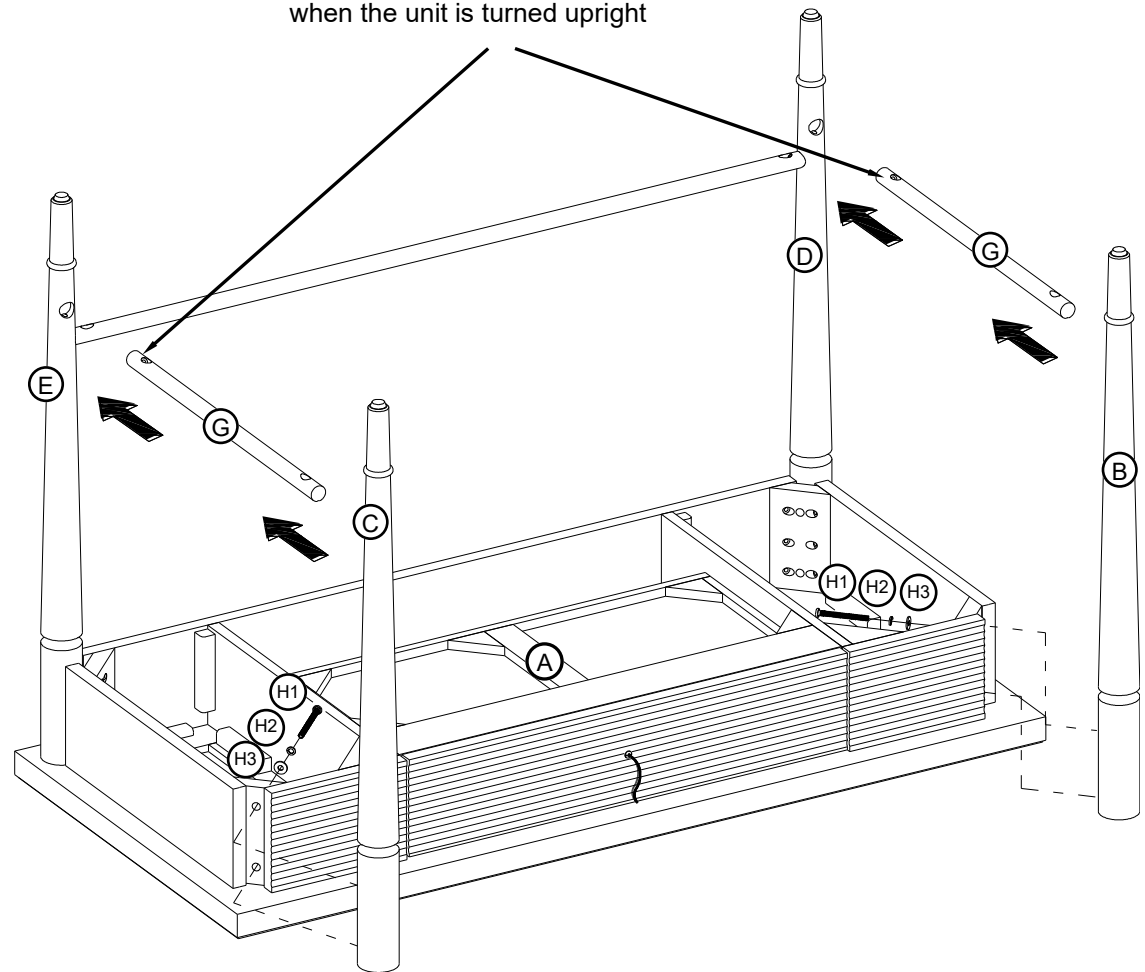

(H1) x 4
2 1/2" bolt

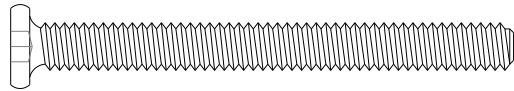

(H2) x 4
lock washer



(H3) x 4
flat washer

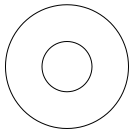

(H5) x 1
hex wrench



Attach the front legs (B and C) to the desk top (A) loosely and insert the side stretchers (G) between the legs properly.

step 3.

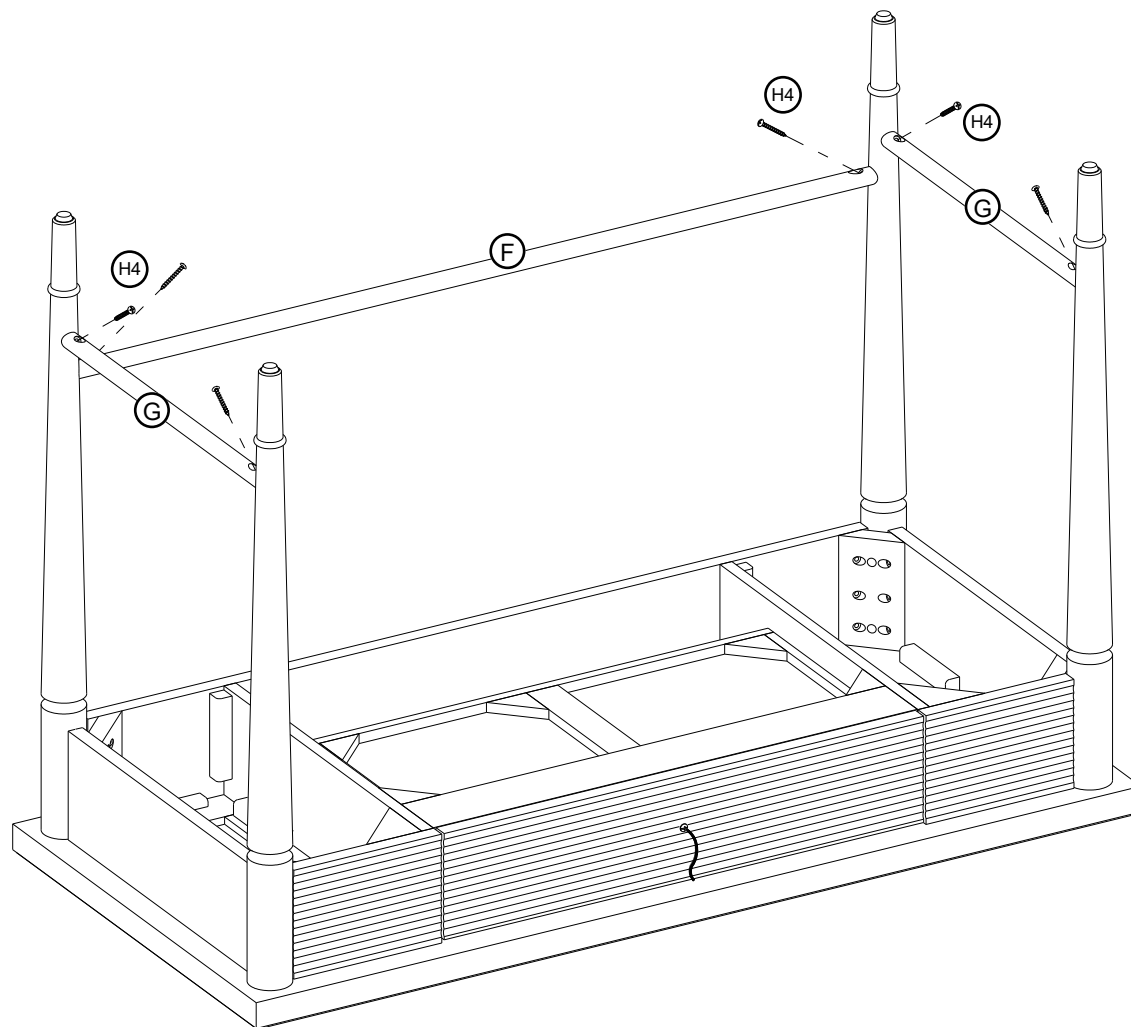

(H4) x 6
1 1/2" screw

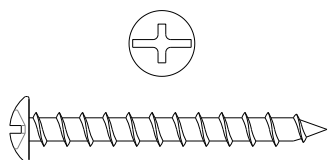

Go back and fully tighten all the bolts. Proceed to fasten the bottom stretchers (F and G) in place.

step 4.

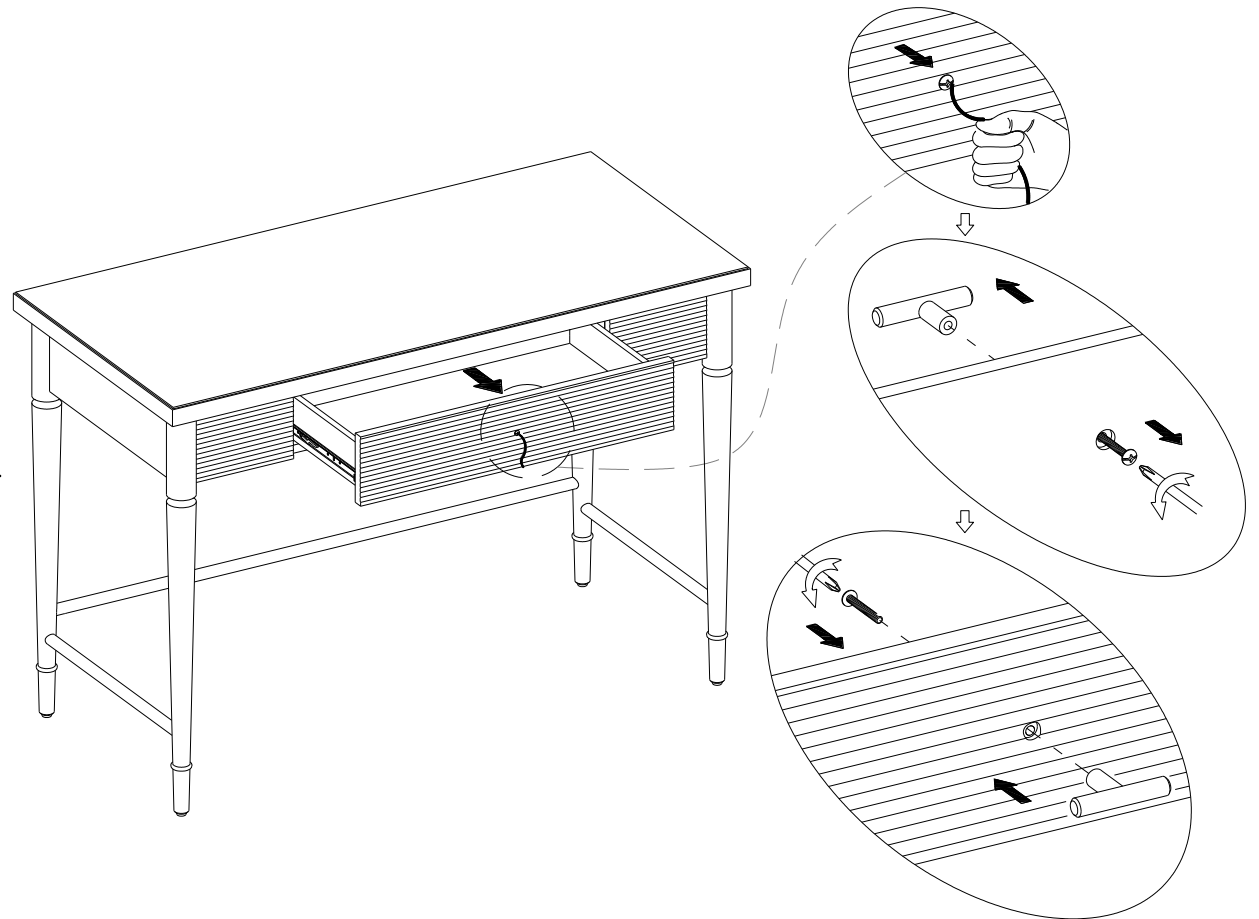

Stand the unit upright.

The table top comes with the handle pre-assembled to the inside of the utility drawer.

Unscrew the small bolt to remove the handle. Reinstall the handle to the front of the utility drawer with the small bolt.

step 5.



(H6) x 2
tipping restraint hardware kit

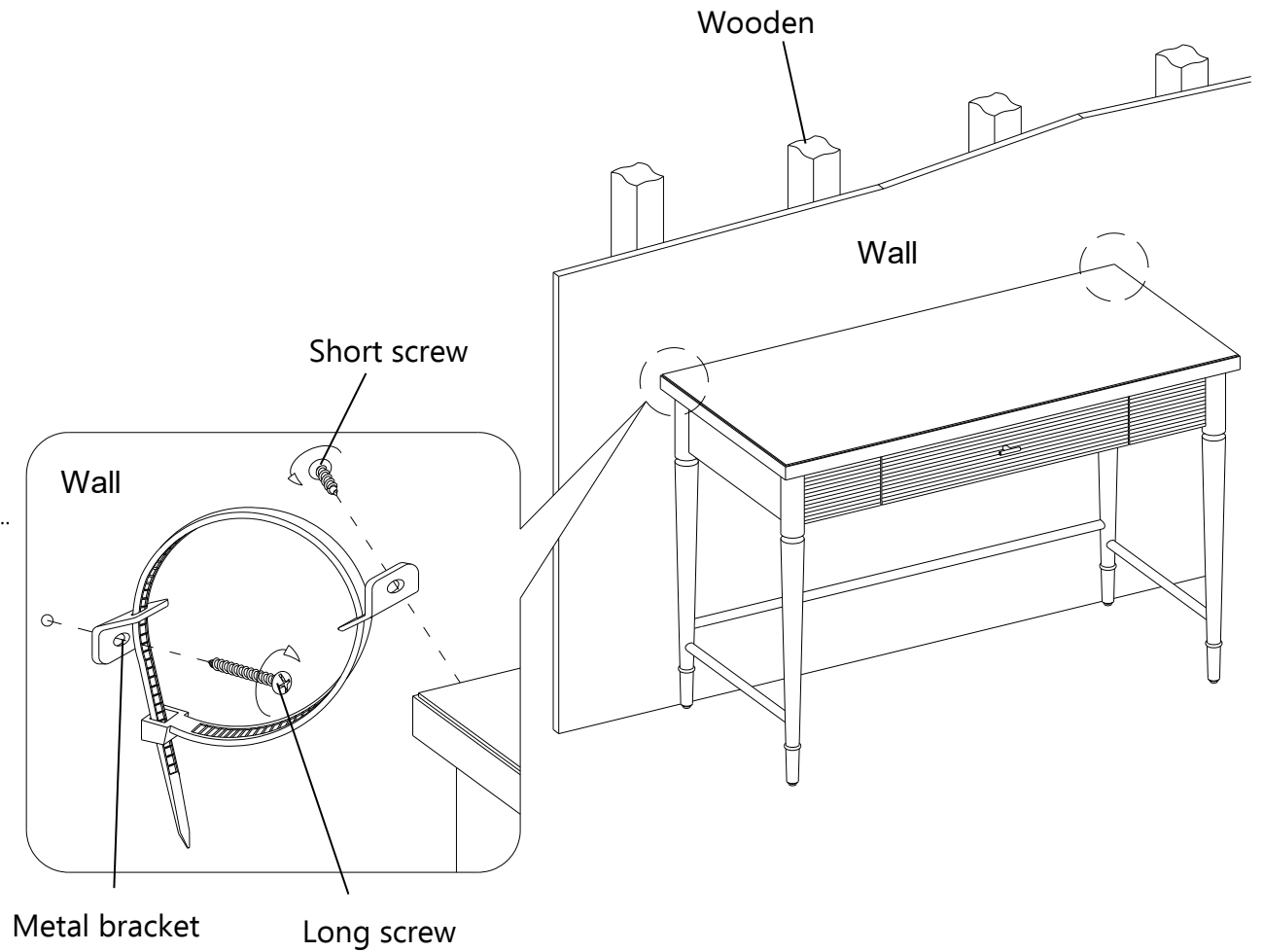
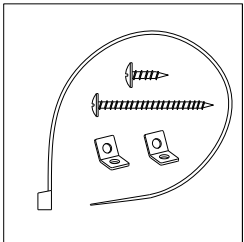

Tools required: Phillips screwdriver, mallet, power drill, and 1/8" drill bit.

Position the unit at the desired location against a wall.

Follow the instructions printed on plastic bag containing tipping restraint hardware to attach tip-over restraint between the unit and wall.

NOTE: You must use this tipping restraint to attach this unit to the wall, to prevent accidents and/or injuries.

The desk is now ready for use.

Care and Maintenance

- Use a soft, clean cloth that will not scratch the surface when dusting.
- Use of furniture polish is not necessary. Should you choose to use polish, test first in an inconspicuous area.
- Using solvents of any kind on your furniture may damage the finish.
- Never use water to clean your furniture as it may cause damage to the finish.
- Always use coasters under beverage glasses and flowerpots.
- Liquid spills should be removed immediately. Using a soft, clean cloth, blot the spill gently. Avoid rubbing.
- Always use protective pads under hot dishes and plates. Heat can cause chemical changes that may create spotting within the furniture finish.
- Stains or marks from crayons or ink markers will be difficult to remove.
- In the event that your furniture is stained or otherwise damaged during use, we recommend that you call a professional to repair your furniture.
- Check bolts/screws and nuts periodically and tighten them if necessary.

Further Advice about Wood Furniture Care

It is best to keep your furniture in a climate-controlled environment. Extreme temperature and humidity changes can cause fading, warping, shrinking and splitting of wood. It is advised to keep furniture away from direct sunlight as sun may damage the finish.

Proper care and cleaning at home will extend the life of your purchase. Following these important and helpful tips will enhance your furniture as it ages.

We hope you enjoy your purchase for many years.
Thank you for your purchase!

QUALITY GUARANTEE

We are confident that you will be delighted with your Whalen Furniture purchase.

Should this product be defective in workmanship or materials or fail under normal use, we will repair or replace it for up to one (1) year from date of purchase. Every Whalen Furniture product is designed to meet your highest expectations. We guarantee that you will immediately see the value of our fine furniture.

This warranty gives you specific al rights and you may also have other rights which vary from state to state or province to province.

Customer Service: 1-855-MYTGTHOME (855-698-4846)
8:30 a.m. - 4:30 p.m., PST, Monday to Friday
www.whalenfurniture.com

The maximum recommended weight allowance is 90.8 kg / 200 lb for top surface.

The maximum recommended weight allowance is 9.1 kg / 20 lb for drawer.

WARNING

Please use your furniture correctly and safely. Improper use can cause safety hazards, or damage to your furniture or household items. Carefully read the following safety information.

Death or serious injury may occur when children climb on audio and/or video equipment furniture. A remote control or toys placed on the furnishing may encourage a child to climb on the furnishing and as a result may tip over onto the child.

NEVER allow children to climb or play with the TV or furnishing supporting the TV.

NEVER place toys, food, remote, etc. on top of the TV or TV furnishing.

ALWAYS use either the safety hardware as instructed or other wall anchoring device.

Relocating audio and/or video equipment to furniture not specifically designed to support audio and/or video equipment may result in death or serious injury due to furniture collapse or over turning onto a child.

NEVER place a TV on furniture that is not intended to support a TV.

NEVER exceed the maximum size and weight of the TV shown in the instructions.

Be sure to refer to the TV warning label as shown in the instructions.

Overloading drawers and shelves may result in furniture that can break or sag, or tip-over which may result in injury.

NEVER exceed the weight limits shown in the instructions.

Place the heavier items on lower shelves as far back from the front as possible.

Load the bottom surfaces first to avoid top-heavy furniture.

Moving furniture that is not designed to be moved or equipped with casters may result in injury or damage to furnishings or personal property.

ALWAYS unload shelves and drawers, starting with the top surfaces, before moving.

NEVER push or pull furniture on carpet. Have a friend help lift properly to move and/or reposition it.

The table is not meant as a seat and no one should be sitting or standing on the table.

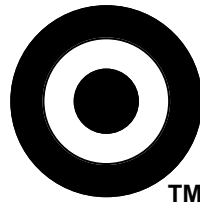

TM