

# Thomasville®

LOT NUMBER: \_\_\_\_\_

DATE PURCHASED: \_\_/\_\_/\_\_

## Whitney Lateral File Model # SPLS-WHLF-TV

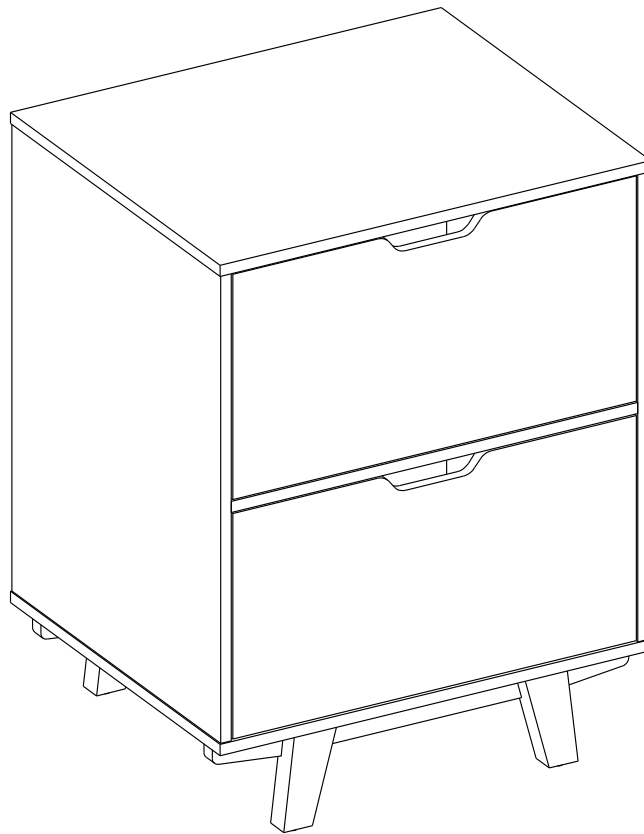

**ADULT ASSEMBLY REQUIRED DUE TO THE PRESENCE OF SMALL PARTS, SHARP POINTS, SHARP EDGES AS RECEIVED**

If you have any questions regarding assembly or if parts are missing, **DO NOT** return this item to the store where it was purchased. Please call our toll-free customer service number and have your instructions and parts list ready to provide the model name, part name or factory number:

**1-866-942-5362**

Pacific Standard Time: 8:30 a.m. - 4:30 p.m., Monday - Friday

Or visit our web site 24 hours a day, 7 days a week for product assistance at

**[www.whalenfurniture.com](http://www.whalenfurniture.com)**

Or e-mail your request to **[parts@whalenfurniture.com](mailto:parts@whalenfurniture.com)**

**THIS INSTRUCTION BOOKLET CONTAINS IMPORTANT SAFETY INFORMATION.  
PLEASE READ AND KEEP FOR FUTURE REFERENCE.**

Date 2021-02-23

Rev. 0001-A

Thomasville™ is a trademark of HHG IPCo, LLC. ©HHG IPCo, LLC. [thomasville.com](http://thomasville.com)

## MAXIMUM RECOMMENDED WEIGHT LOADS

MANUFACTURER: Whalen Furniture Manufacturing  
CATALOG: Whitney Lateral File  
MODEL # SPLS-WHLF-TV

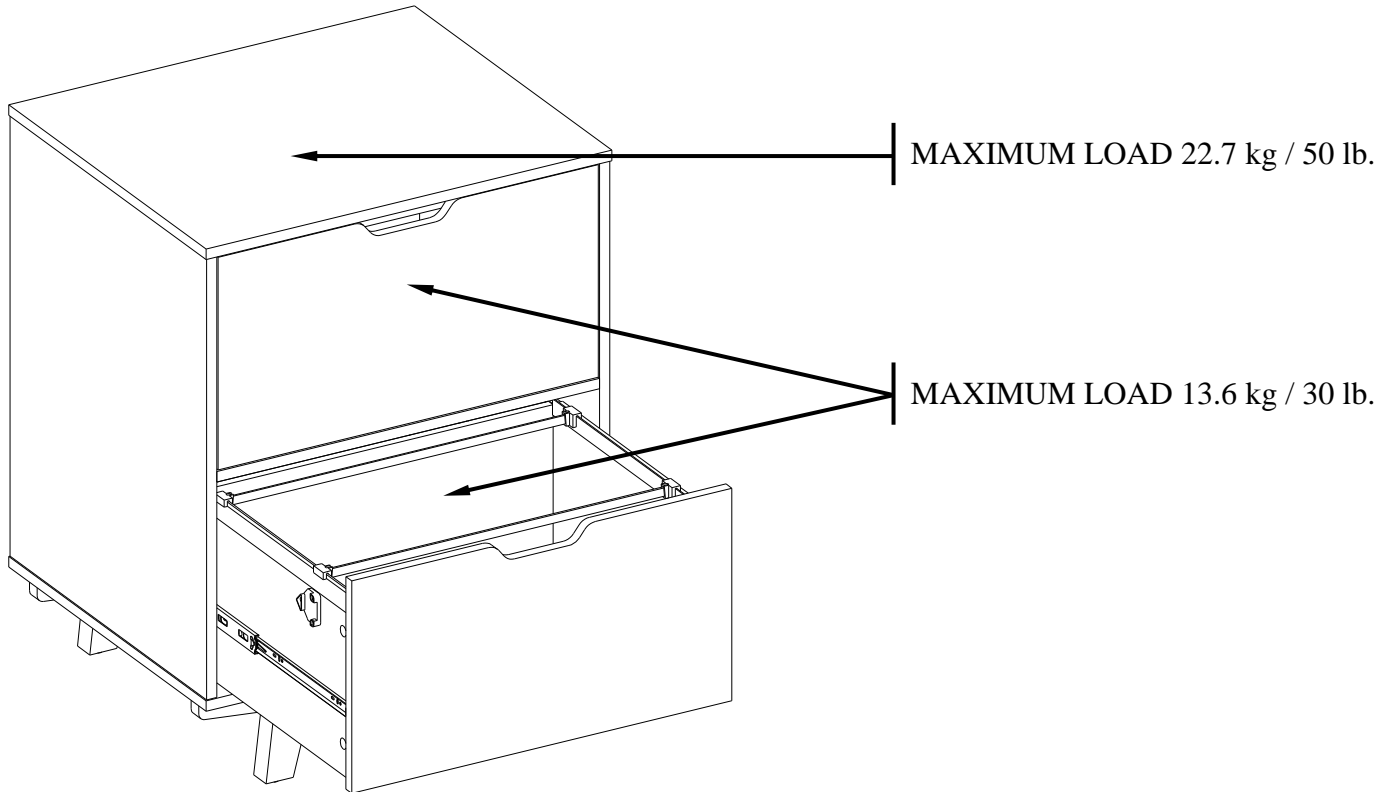

**⚠ WARNING** THIS UNIT IS INTENDED FOR USE ONLY WITH THE MAXIMUM WEIGHTS INDICATED. USE WITH LOAD HEAVIER THAN THE MAXIMUM WEIGHTS INDICATED MAY RESULT IN INSTABILITY, CAUSING POSSIBLE INJURY.

### SPECIAL NOTE



Please read the instruction sheets completely before assembly. Examine all packaging material before discarding carton. Remove any remaining staples from the carton before discarding. Remove all parts from carton and separate into groups as indicated on part list. Please ensure all parts are included prior to assembly. Use of power tools to complete assembly is not recommended.

# FURNITURE TIPPING RESTRAINT

**YOUNG CHILDREN MAY BE INJURED BY TIPPING FURNITURE AND YOU MUST USE THIS TIPPING RESTRAINT TO ATTACH THIS UNIT TO THE WALL, TO PREVENT ACCIDENTS AND/OR INJURIES.**

**THIS HARDWARE MUST BE PROPERLY INSTALLED (FOLLOW ALL DIRECTIONS IN ORDER ON THIS INSTRUCTIONS), TO PROVIDE PROTECTION AGAINST THE UNEXPECTED TIPPING OF FURNITURE DUE TO IMPROPER USE.**

**THIS PRODUCT IS ONLY A DETERRENT. IT IS NOT A SUBSTITUTE FOR PROPER ADULT SUPERVISION. USE OF TIP-OVER RESTRAINTS MAY ONLY REDUCE, BUT NOT ELIMINATE, THE RISK OF TIP-OVER.**

 <b>WARNING</b>	
	<p><b>Children have died from furniture tipover. To reduce the risk of furniture tipover:</b></p> <ul style="list-style-type: none"><li>• ALWAYS install tipover restraint provided.</li><li>• NEVER put a TV on this product.</li><li>• NEVER allow children to stand, climb or hang on drawers, doors, or shelves.</li><li>• NEVER open more than one drawer at a time.</li><li>• Place heaviest items in the lowest drawers.</li></ul>
	<p><b>Use of tip-over restraints may only reduce, but not eliminate, the risk of tip-over.</b></p>

## Parts and Hardware List

Please read completely through the instructions and verify that all listed parts and hardware are present before beginning assembly.

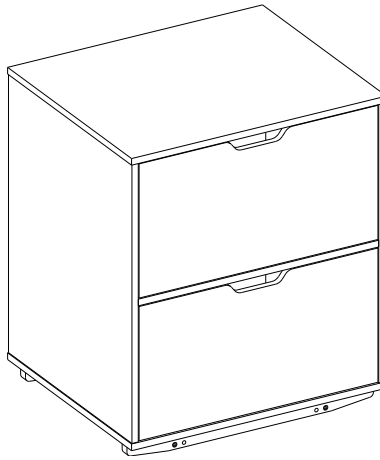

A- File Cabinet (Qty. 1)

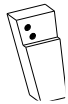

B- Left Front / Right Back Leg (Qty. 2)

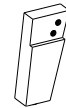

C- Right Front / Left Back Leg (Qty. 2)

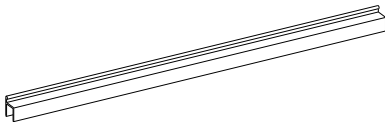

D- Guide Rail (Qty. 4)



E- Guide Block (Qty. 8)

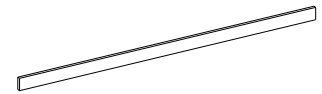

F- File Hanger (Qty. 4)

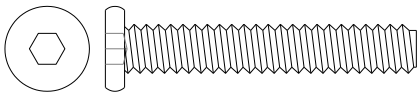

(1) 1/4" x 38 mm Bolt (Qty. 8+1 extra)



(2) Lock Washer (Qty. 8+1 extra)

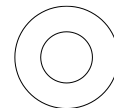

(3) Flat Washer (Qty. 8+1 extra)

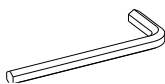

Hex Wrench (Qty. 1)

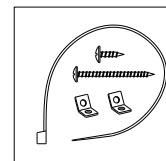

Tipping Restraint Hardware Kit (Qty. 1)  
(Included in plastic bag)

Tools required: Hex wrench (provided) and Phillips screwdriver (not provided).

# DRAWER INSTALLATION

If you need to remove the drawers with ball bearing slides from the unit, please follow the steps below to prevent any damage to the slides or the drawers.

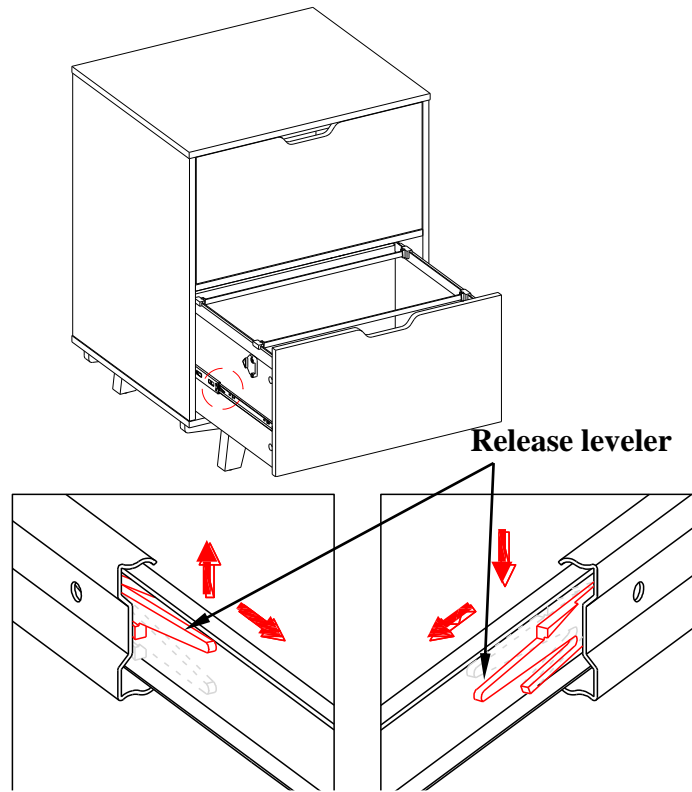

1. If you need to remove the drawer, please pull the drawer all the way out, then simultaneously pushes the plastic release lever of the ball bearing slide up on one side and down on the other side, and then pull the drawer completely out.

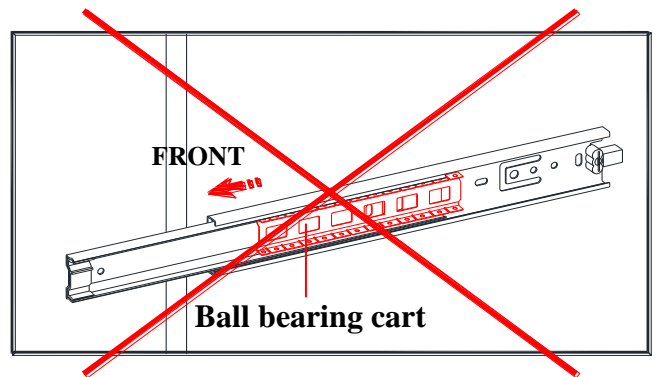
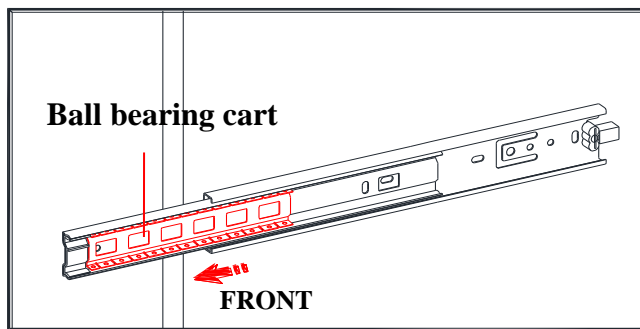

2. To place the drawer back, simply push the ball bearing cart all the way to the end of the slides (in both sides) and align the slide runners on the drawer with the slide tracks on the unit and push it carefully inside until it stops.

**NOTE:** If the drawer does not go in smoothly, please take it out and repeat the step.

## Assembly Instructions

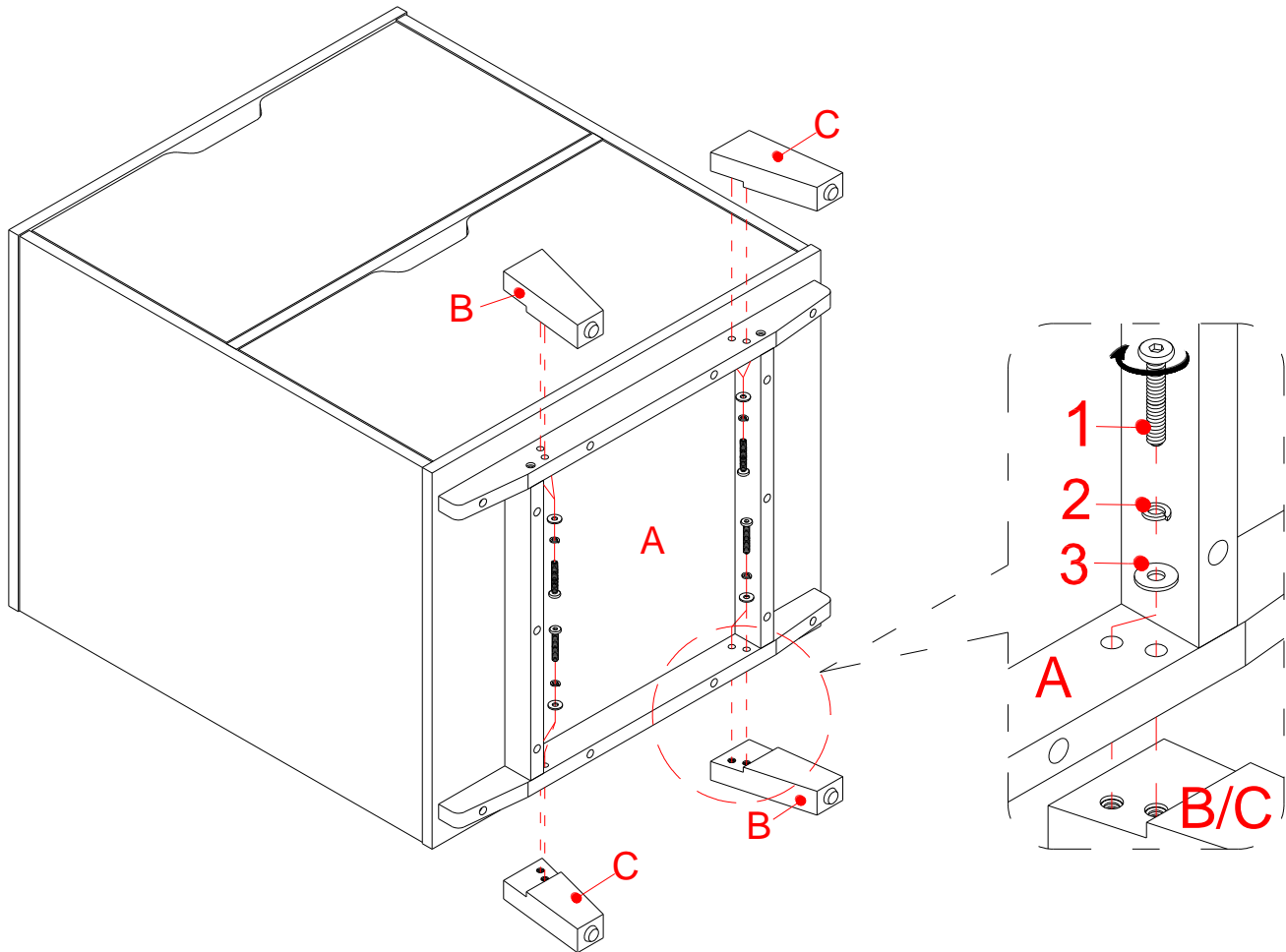

**NOTE:** Please do not fully tighten all bolts until you finish assembling all parts. Once assembled, go back and fully tighten all bolts. This will make the assembly easier.

1. Unpack the unit and confirm that you have all the hardware and required parts. Assemble the unit on a carpeted floor or the empty carton to avoid any scratch.
2. Lay the file cabinet (A) and attach the Legs (B and C) to the bottom rails with eight 38 mm Bolts (1) and eight Washers (2 and 3) as shown.

## Assembly Instructions

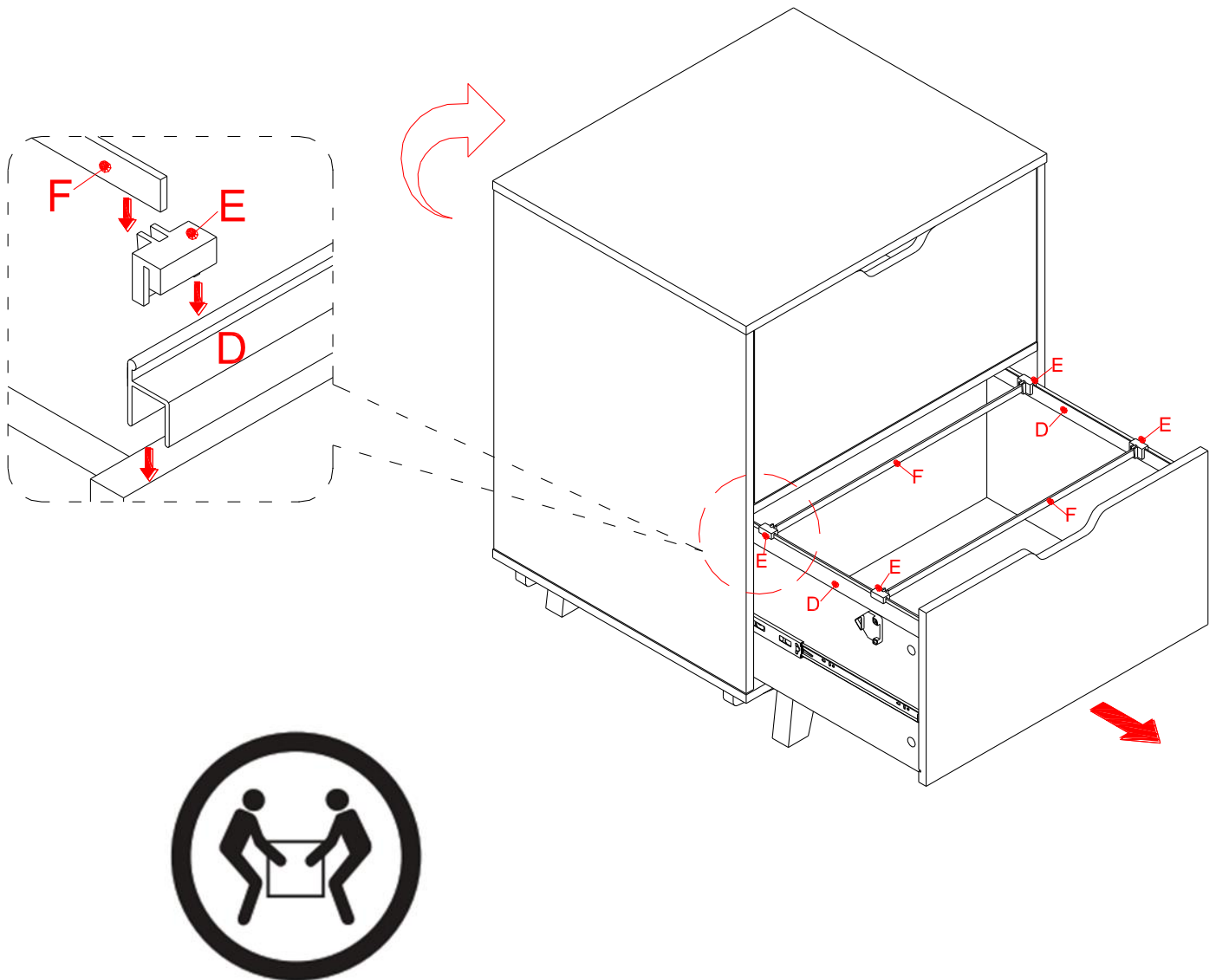

3. Ask for assistance to lift the assembled unit upright.
4. Position the Guide Rails (D) onto the drawer sides with the high side facing inward.
5. Hook four Guide Blocks (E) onto the high edge of Guide Rails (D). Now set the File Hangers (F) into the slot of Guide Blocks (E). Slide the file hangers forward and backward to keep hanging files organized.
6. Repeat the same procedure to attach the remaining Guide Rails (D), Guide Blocks (E) and File Hangers (F) to the other drawer.

## Assembly Instructions

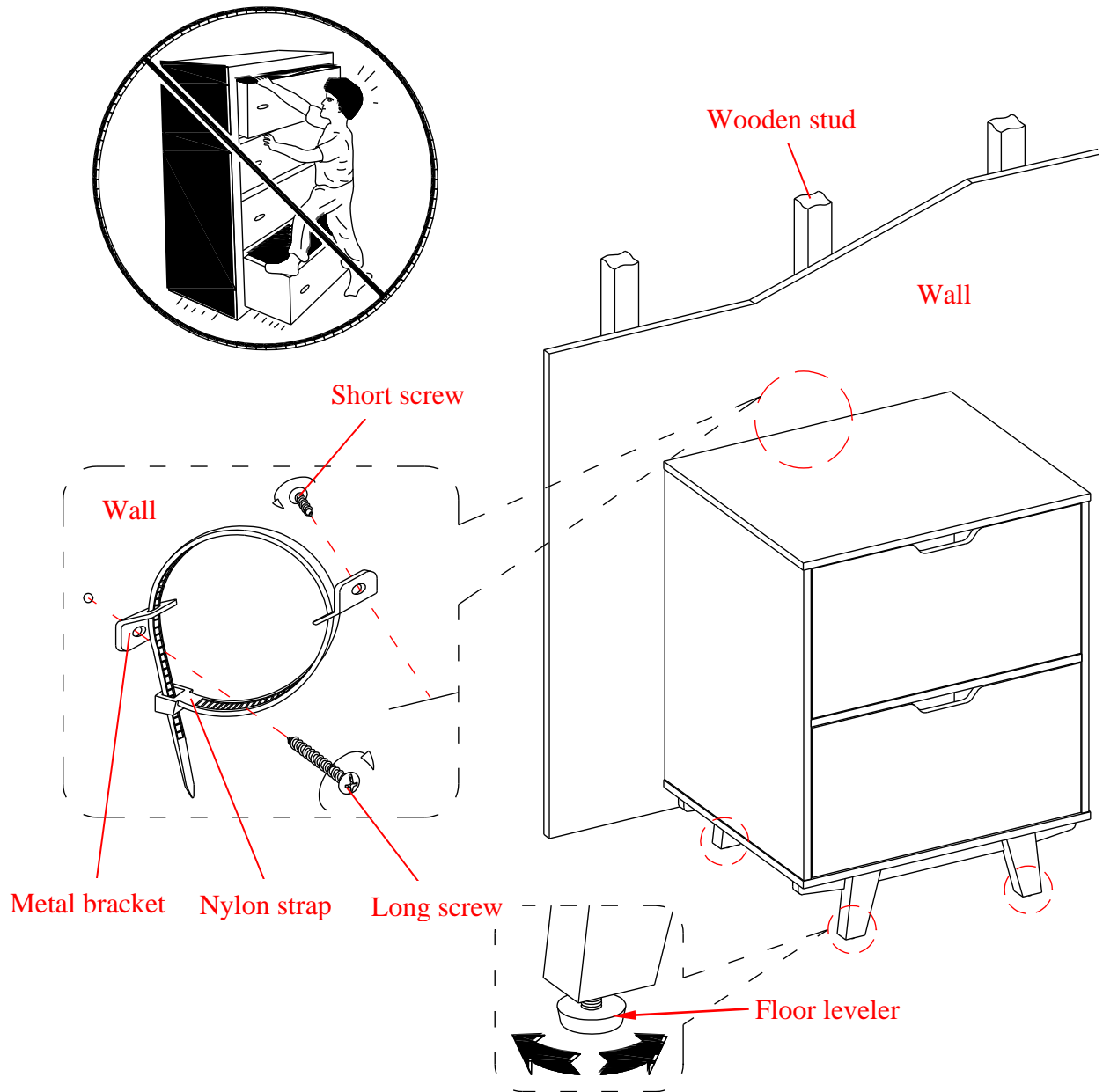

Tools required (not provided): Phillips screwdriver, stud finder, tape measure, pencil, power drill and 1/8" drill bit.

7. Position the unit at the desired location against a wall. If necessary, adjust the Floor Levelers at the bottom of the Legs (B and C) to level the unit.
8. Now, follow the instructions printed on the plastic bag containing the Tipping Restraint Hardware to attach the tip-over restraints to the unit and the wall.

**NOTE:** The tipping restraint hardware included is for wooden stud wall construction. It must be attached to a wall stud. Depending upon your wall construction, different anchor hardware maybe required. Please contact your local hardware store for assistance. Young children can be seriously injured by tipping furniture. You must install the tipping restraint hardware with the unit to prevent the unit from tipping, causing any accidents or damage. The tipping restraints are intended only as a deterrent, they are not a substitute for proper adult supervision. The tipping restraints are not earthquake restraints. If you wish to add the extra security of earthquake restraints, they must be purchased and installed separately.



## Care and Maintenance

- Use a soft, clean cloth that will not scratch the surface when dusting.
- Gently rub the surface with a soft dry cloth, soft damp cloth, or soft damp cloth with neutral detergent, and then dry it well.
- Strong Alkaline detergents or acidic detergents are not recommended to use.
- Sponges containing abrasive agents or fibers are not recommended to use.
- Use of furniture polish is not necessary. Should you choose to use polish, test first in an inconspicuous area.
- Using solvents of any kind on your furniture may damage your furniture's finish.
- Never use water to clean your furniture as it may cause damage to the finish.
- Always use coasters under beverage glasses and flowerpots.
- Liquid spills should be removed immediately. Using a soft, clean cloth, blot the spill gently. Avoid rubbing.
- Always use protective pads under hot dishes and plates. Heat can cause chemical changes that may create spotting within the furniture finish.
- In the event that your furniture is stained or otherwise damaged during use, we recommend that you call a professional to repair your furniture.
- Check bolts/screws periodically and tighten them if necessary.

## Further Advice about Wood Furniture Care

It is best to keep your furniture in a climate-controlled environment. Extreme temperature and humidity changes can cause fading, warping, shrinking and splitting of wood. It is advised to keep furniture away from direct sunlight as sun may damage the finish.

Proper care and cleaning at home will extend the life of your purchase. Following these important and helpful tips will enhance your furniture as it ages.

We hope you enjoy your purchase for many years.  
Thank you for your purchase!

## QUALITY GUARANTEE

We are confident that you will be delighted with your Whalen Furniture purchase.

Should this product be defective in workmanship or materials or fail under normal use, we will repair or replace it for up to one (1) year from date of purchase. Every Whalen Furniture product is designed to meet your highest expectations. We guarantee that you will immediately see the value of our fine furniture.

This warranty gives you specific legal rights and you may also have other rights which vary from state to state or province to province.

Whalen Furniture Manufacturing  
1578 Air Wing Road, San Diego CA, 92154, USA  
Customer Service: 1-866-942-5362  
8:30 a.m. - 4:30 p.m., PST, Monday to Friday  
[www.whalenfurniture.com](http://www.whalenfurniture.com)