

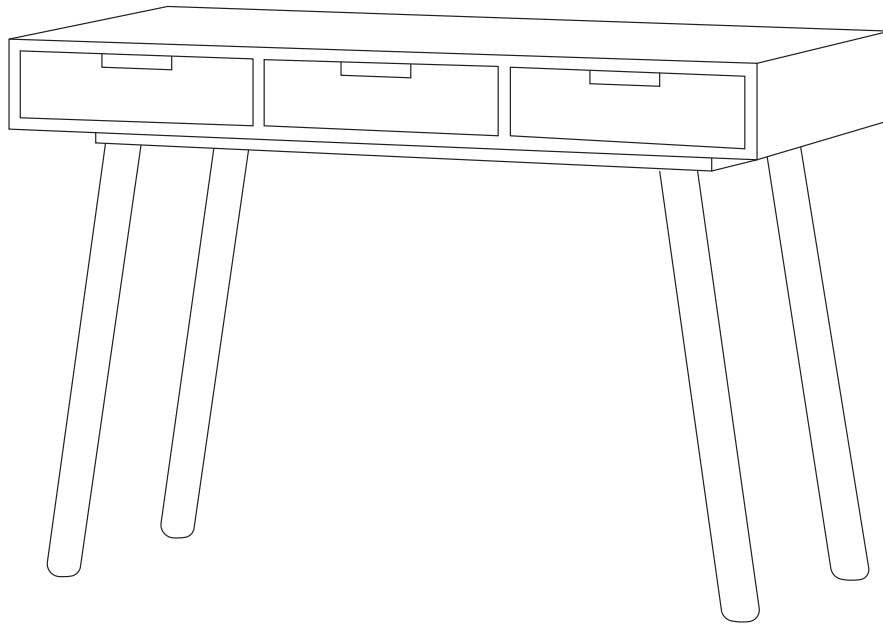

EXCLUSIVELY FOR
Office DEPOT®



STARA Writing Desk

Assembly instructions and warranty information

Bureau

Instructions pour l'assemblage et information sur la garantie

Escritorio

Instrucciones para el ensamblaje e información sobre la garantía

Date Manufactured / Date de fabrication / Fecha de manufactura: _____

Lot # / Nombre de sort / Número de lote: _____

Guidelines/ Consignes/ Directrices

Thank you for selecting an Elle Decor Collection piece!

Our primary objective is to provide fast, friendly customer service to all of our customers. We are here to help if you have any questions, comments, or are in need of warranty replacement parts. The Vendor Sticker can be found under the desktop toward the front end.

Please call us toll free at: 1-866-942-5362
(Monday - Friday 8:30 am - 4:30 pm PST)
Or e-mail your request to parts@whalenfurniture.com

Or visit our website:
www.whalenfurniture.com

FAILURE TO FOLLOW THESE WARNINGS WHEN IN USE COULD RESULT IN INJURY

- Do not stand on the item or use as a step ladder.
- The unit has been tested and approved for maximum load weight is 200 (90.8kg) pounds.
- Do not use this item unless all bolts and screws are firmly secured and fastened.
- Check all bolts and screws every 90 days. As necessary tighten if any are loose.
- Lift up then move. Pushing over or dragging this product can result in an injury or cause damage to the floor and piece.

Merci d'avoir choisi un produit Elle Décor Collection !

Notre premier objectif est de fournir un service client rapide et amical à tous nos clients. Nous sommes là pour vous aider si vous avez des questions, commentaires ou avez besoin d'éléments de remplacements sous garantie. L'autocollant Vendor se trouve sous le bureau vers l'extrémité avant.

Appelez-nous sans surcout au : 1-866-942-5362
(Lundi- Vendredi 8:30 am - 4:30 pm PST)
Ou adressez-nous votre demande par email à parts@whalenfurniture.com

Ou rendez-vous sur notre site :
www.whalenfurniture.com

NE PAS RESPECTER CES MISES EN GARDE EN COURS D'UTILISATION PEUT OCCASIONNER DES BLESSURES

- Ne vous tenez pas debout sur le produit et ne l'utilisez pas comme marchepied.
- Ce produit a été testé et approuvé pour supporter un poids maximal de 200 livres (90,8 kgs).
- N'utilisez pas le produit si l'ensemble des boulons et des vis n'a pas été fermement vissé et serré.
- Vérifiez l'ensemble des boulons et des vis tous les 90 jours. Serrez-les s'ils sont relâchés.
- Soulevez avant de déplacer. Pousser ou tirer le produit peut occasionner des blessures ou endommager le sol ou le produit.

¡Gracias por elegir una pieza de la Colección Elle Decor!

Nuestro objetivo principal es proporcionar un servicio rápido y cercano a todos nuestros clientes. Le ayudaremos si tiene preguntas, comentarios o si necesita piezas de repuesto en garantía. La Etiqueta del Proveedor se encuentra debajo del escritorio, en la parte delantera.

Por favor llámenos gratis al: 1-866-942-5362
(De lunes a viernes de 8:30 am - 4:30 pm hora del Pacífico)
O envíenos su consulta al email parts@whalenfurniture.com

O visite nuestra página web:
www.whalenfurniture.com

EL NO CUMPLIMIENTO DE ESTAS ADVERTENCIAS CUANDO SE UTILICE EL PRODUCTO PUEDE CAUSAR LESIONES

- No se suba en el producto ni lo utilice como escalera.
- El producto ha sido probado y homologado para un peso máximo de carga de 200 libras (90,8 kg).
- No utilice este producto a menos que todos los tornillos y tuercas estén apretados y asegurados firmemente.
- Compruebe todos los tornillos y tuercas cada 90 días. Apriételes lo que sea necesario si están sueltos.
- Levántelo para desplazarlo. Empujar o arrastrar este producto puede provocar lesiones o dañar el suelo y el producto.

Pre-Assembly Preparation/ Préparation pré-assemblage/ Preparación previa al montaje:

Please read through this instruction booklet before beginning assembly of this item.

Two adults are recommended for assembly.

- Clear out the space for assembly and lay out all parts on Parts List, extra room will allow you to easily determine if all the pieces are present.
- Save all packing materials until assembly is complete to avoid accidentally discarding smaller parts or hardware.
- Keep small parts and pieces away from children and pets until fully assembled.
- Please check for any loose screws and tighten them before you use.

Lisez le présent manuel d'instruction avant de commencer l'assemblage du produit.

La participation de deux adultes est recommandée pour procéder à l'assemblage.

- Libérez un espace pour l'assemblage et disposez tous les éléments de la Liste des Eléments, de la place supplémentaire vous permettra de vérifier que tous les éléments sont disponibles.
- Conservez tous les éléments d'emballage jusqu'à complétion de l'assemblage afin d'éviter de jeter accidentellement de petits éléments ou du matériel.
- Gardez les petits éléments et pièces hors de la vue des enfants et des animaux jusqu'à finalisation de l'assemblage.
- Vérifiez qu'aucune vis n'est lâche et resserrez-les si besoin.

Por favor, lea este manual de instrucciones antes de comenzar el montaje de este artículo.

Se recomienda el montaje entre dos adultos.

- Despeje el espacio destinado para el montaje y coloque todas las partes que aparecen en la Lista de piezas, disponer de un espacio adicional le permitirá ver fácilmente si dispone de todas las piezas.
- Guarde todos los materiales del embalaje hasta que haya completado el montaje, para evitar desechar accidentalmente piezas pequeñas o hardware.
- Mantenga las partes y piezas pequeñas fuera del alcance de los niños y de las mascotas hasta que esté completamente montado.
- Por favor compruebe cualquier tornillo suelto y apriételo antes de comenzar a utilizar el artículo.

WARNING: DO NOT LET CHILDREN PLAY IN OR AROUND THE UNIT DUE TO THE POSSIBLE RISK OF INJURY.

ATTENTION : NE LAISSEZ PAS D'ENFANTS JOUER SUR OU A CÔTE DU PRODUIT EN RAISON DES RISQUES DE BLESSURES.

ATENCIÓN: NO DEJE QUE LOS NIÑOS JUEGUEN EN EL PRODUCTO O ALREDEDOR DE ÉL DEBIDO AL POSIBLE PELIGRO DE LESIONES.

Parts List/ Liste des éléments/ Lista de piezas

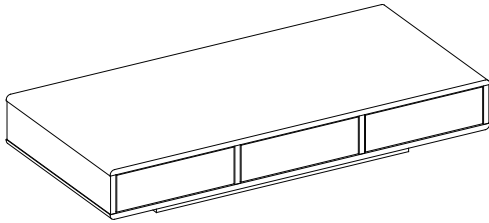

A Desk Top/
Plateau/
Tablero del escritorio (1)

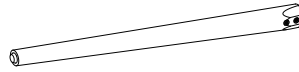

B Legs/
Pieds/
Patas (4)

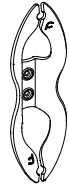

C Cable Wheels/
Guide-câbles/
Guías para cables (2)

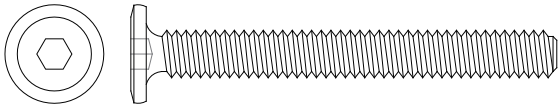

1 1/4" x 2 1/8" Bolts/
1/4" x 2 1/8" Boulons/
1/4" x 2 1/8" Tornillos (8 + 1 extra)



2 Lock Washers/
Rondelles de blocage/
Arandelas de sujeción (8 + 1 extra)

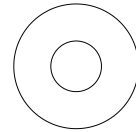

3 Flat Washers/
Rondelles plates/
Arandelas planas (8 + 1 extra)

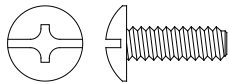

4 1/2" Small Bolts/
1/2" Petits boulons/
1/2" Tornillos pequeños (4 + 1 extra)

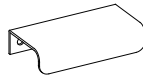

5 Handles/
Poignée/
Tiradores (3)



6 M3.5 x 12 mm Screws/
M3.5 x 12 mm Vis/
M3.5 x 12 mm Tornillos de punta fina (6 + 1 extra)

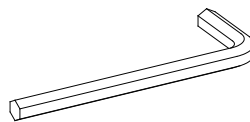

7 Hex Wrench/
Clé hexagonale/
Llave hexagonal (1)

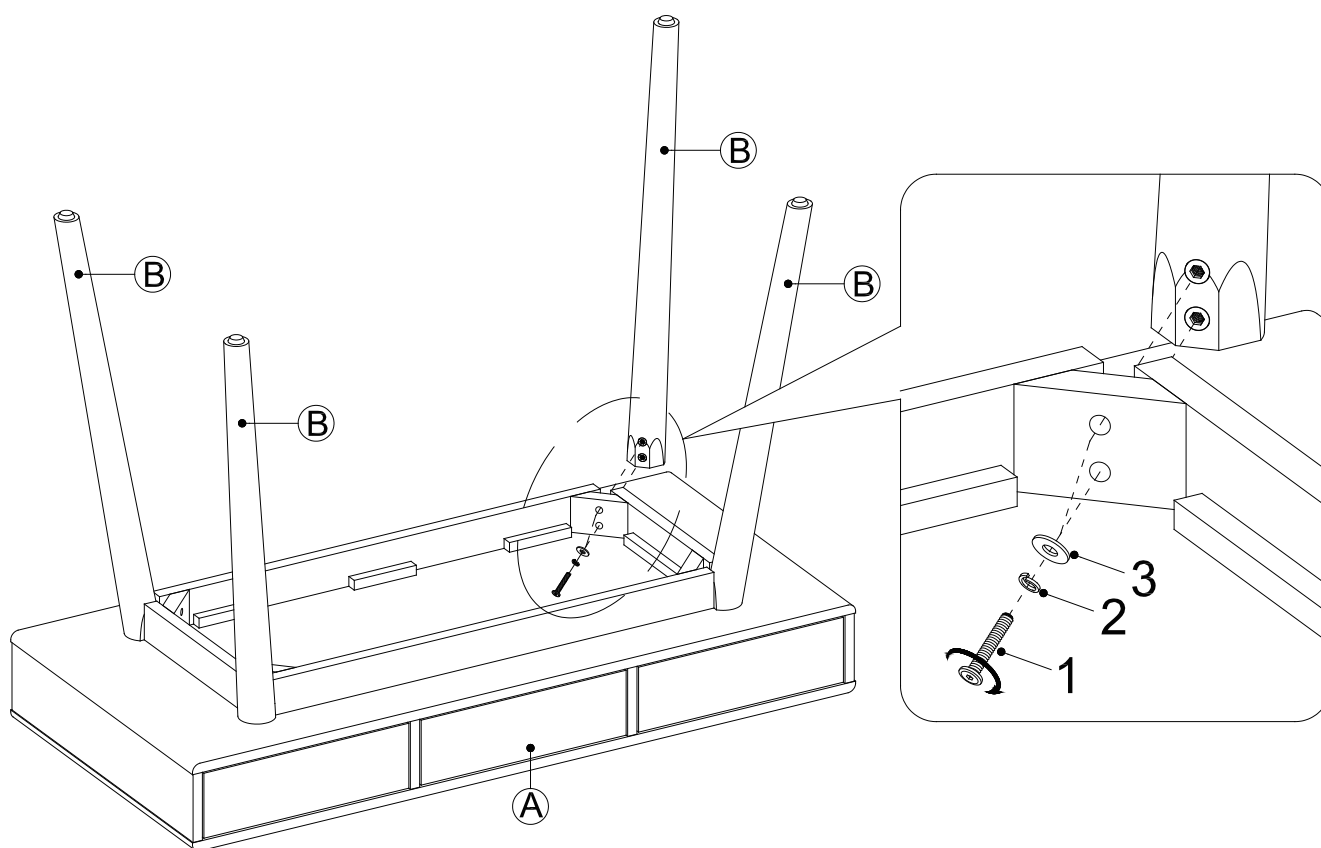
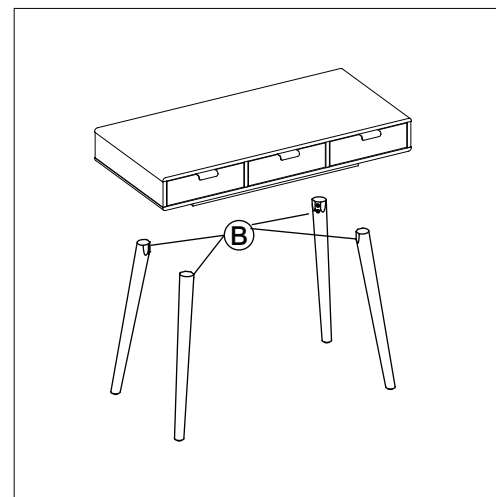
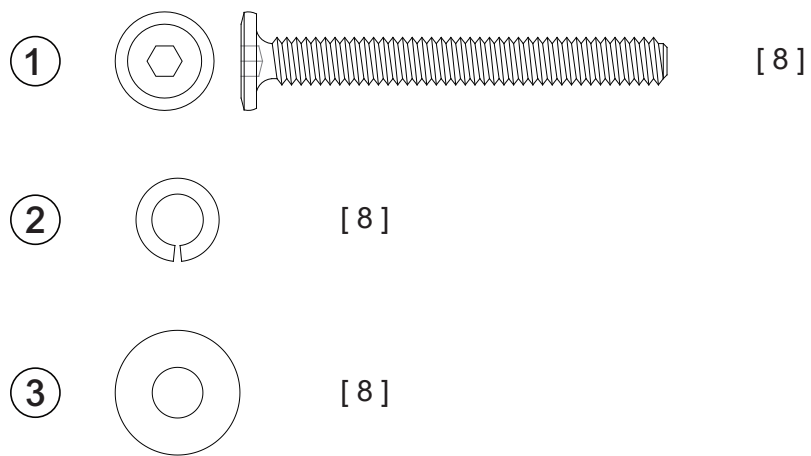

1-- Remove all parts from the carton and place them on a protected surface or carpet. Place the Desk Top (A) upside down and attach each Leg (B) with two 2 1/8" Bolts (1), two Lock Washers (2) and two Flat Washers (3) to the Desk Top.

Retirez tous les éléments du carton et positionnez-les sur une surface protégée ou de la moquette. Positionnez le Plateau (A) à l'envers et fixez les pieds (B) au Plateau avec deux Boulons 2 1/8" (1), deux Rondelles de Blocage (2) et deux Rondelles Plates (3).

Saque todas las piezas de la caja y colóquelas sobre una superficie protegida o una alfombra. Coloque el tablero de la mesa (A) boca abajo y fije cada pata (B) con dos tornillos de 2 1/8" (1), dos arandelas de seguridad (2) y dos arandelas planas (3) al tablero.

5 [3]

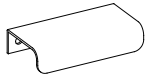

6 [6]

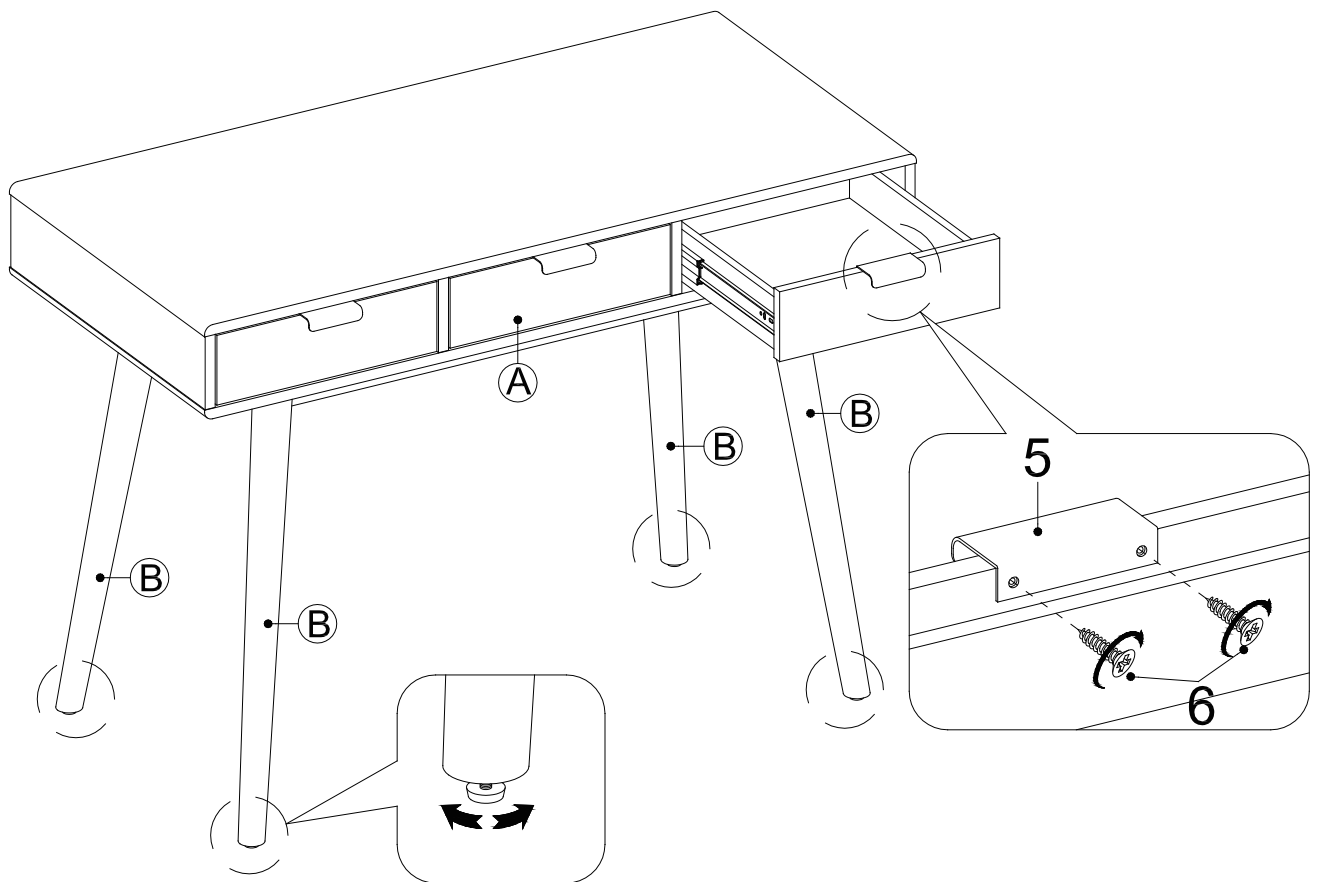
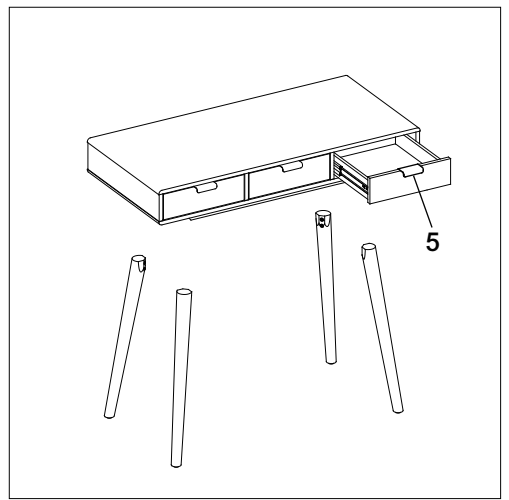
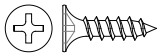

2-- Lift the unit upright. Pull each drawer out to the front and attach one Handle (5) with two Screws (6) to the center of the upper edge of the front panel of each drawer. If necessary, adjust the pre-attached floor levelers to correct tilting. Mettez le produit droit. Positionnez chaque tiroir sur le devant à l'extérieur et attachez une Poignée (5) avec deux Vis (6) au centre du côté supérieur du plateau frontal de chaque tiroir. Si nécessaire, ajustez les niveleurs pré-attachés pour corriger l'inclinaison et/ ou pour mettre les tiroirs à niveau.

Levante toda la pieza y colóquela en posición vertical Tire de cada cajón hacia el frente y fije un tirador (5) con dos tornillos de punta fina (6) en el centro del borde superior del panel frontal de cada cajón. Si es necesario, ajuste las ruedecillas niveladoras montadas en las patas para corregir la inclinación y/o nivelación de los cajones.

4

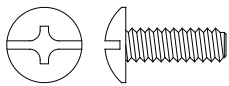

[4]

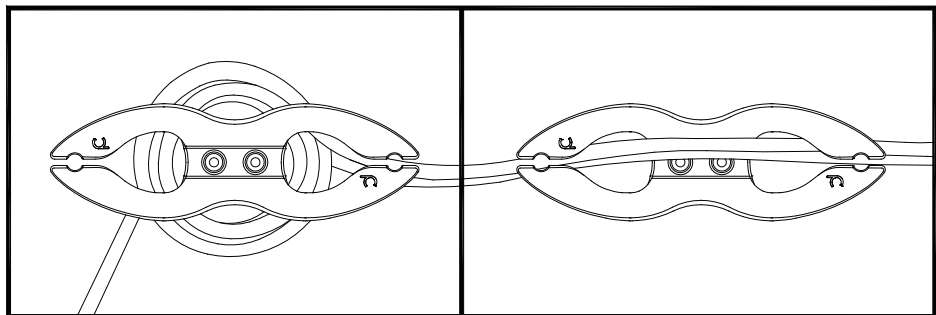
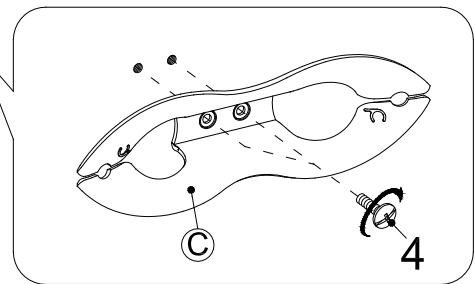
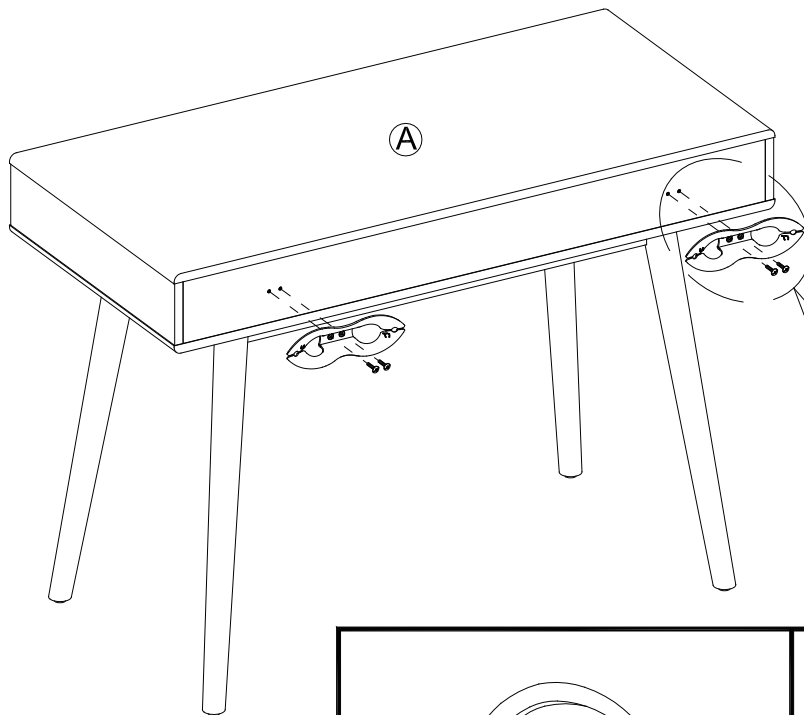
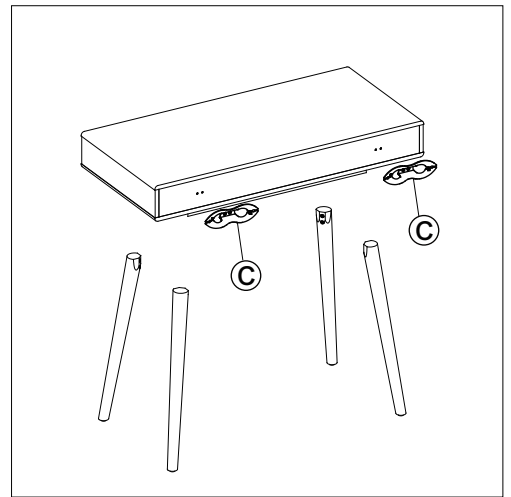

3-- Take the pre-drilled holes as a guide, align and attach the Cable Wheels (C) with 1/2" Small Bolts (4) at the back of the Tabel Top (A) so that the cable can be tidied as image shown.

Utilisez les trous préformés comme guides, alignez et fixez les Guide-Câbles (C) avec les Petits Boulons 1/2" (4) à l'arrière du Plateau (A) afin que le câble puisse être rangé comme indiqué sur l'image.

Tomando los orificios pre-taladrados como guía, alinee y fije las guías para cables (C) con los tornillos pequeños de 1/2" (4) en la parte posterior del tablero de la mesa (A) de manera que el cable pueda ser colocado como se muestra en la imagen.

One Year (1) Limited Warranty

Whalen Furniture products are warranted against defects in material and workmanship while owned by the “Original Purchaser” is defined as that party or entity which purchases Whalen Furniture from an authorized Whalen Furniture retailer as shown by the original sales receipt. This warranty does not apply to “as is” or previously owned products.

Whalen Furniture warrants its products to be free from defects in materials and workmanship (normal wear and tear, fading and stretching excepted), for one (1) year from the date of purchase, except as provided below under the limited warranty.

This warranty gives you specific rights, and you may also have other rights, which vary from state to state. All warranties are limited to the original purchaser for normal use by a maximum of two users. Total weight capacity for the desk top is 200 pounds and for per drawer is 10 pounds.

The exceptions or exclusions to this warranty are:

- Upholstery material and foam cushion material is warranted against defects in material and workmanship for a period of one (1) year, beginning on the date of purchase as shown on the original sales receipt.
- Any warranty claim that is submitted after the limited warranty period, or without proper proof of purchase will not include the cost of parts, labor, or delivery on the warranted parts within a reasonable amount of time. We reserve the right to require damaged parts to be returned to us upon request. Natural markings such as scars, brands, grain variations, wrinkles, color variations, etc. will be considered normal characteristics and not construed as defects.
- For claims or questions concerning this warranty, please contact Whalen Furniture Customer Service department on the web at parts@whalenfurniture.com. Be prepared to provide your name, address, daytime phone number, the model and purchase order number of the product, date of purchase, and the store where it was purchased. Whalen Furniture requires that the original sales receipt be submitted with all requests to confirm that you are the original purchaser according to our written warranty.