

# Origin 21

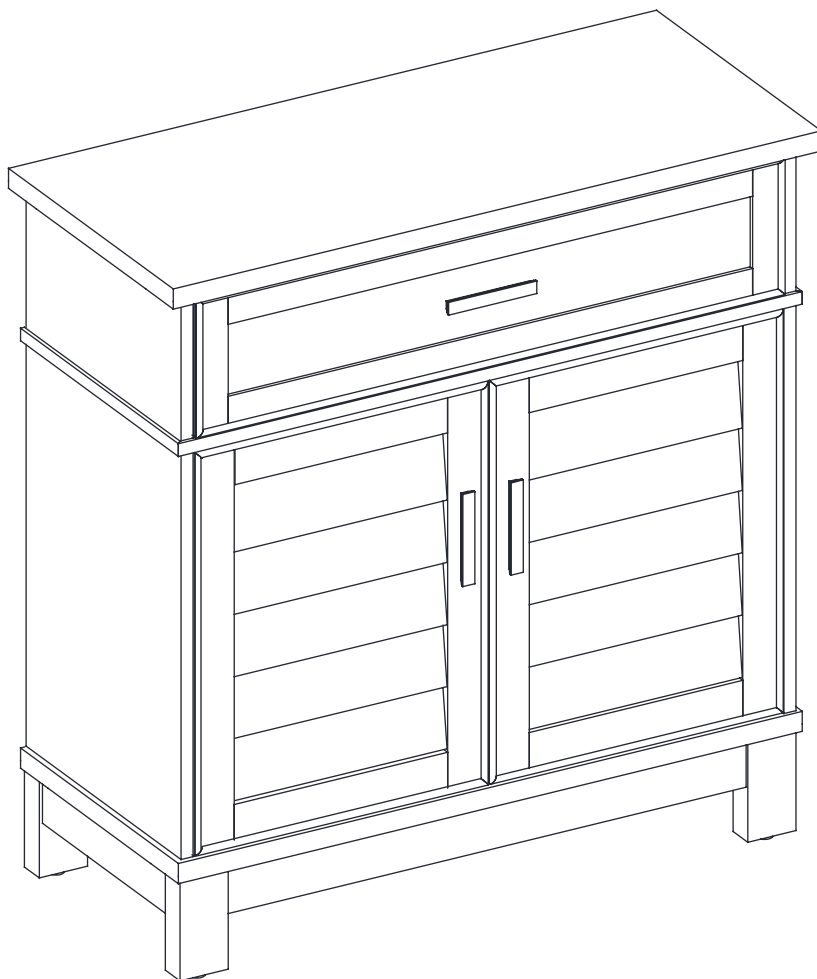

ORIGIN 21 and logo design are trademarks or registered trademarks of LF, LLC. All rights reserved.

ITEM #4911608

## Blue Slat Door Accent Table

MODEL #LWS18AT

Français p. 11

Español p. 21

### ATTACH YOUR RECEIPT HERE

Serial Number \_\_\_\_\_ Purchase Date \_\_\_\_\_

**Questions, problems, missing parts?** Before returning to your retailer, call our customer service department at (888) 251-1026, 8 a.m. - 8 p.m., EST, Monday - Sunday. You could also contact us at [partsplus@lowes.com](mailto:partsplus@lowes.com).

## TABLE OF CONTENTS

---

Hinge Adjustments.....	2
Package Contents.....	3
Hardware Contents.....	4
Safety Information.....	5
Preparation .....	5
Assembly Instructions.....	6
Care and Maintenance .....	8
Limited Lifetime Warranty.....	8
Replacement Parts List .....	9

## Hinge Adjustments

---

### How to adjust the European adjustable hinges on doors

Shipping may cause doors to go out of alignment. If you find that the doors need to be adjusted slightly, turn the appropriate screw, as illustrated.

1. TO ADJUST DOOR FORWARD OR BACKWARD.
2. TO ADJUST DOOR TO RIGHT OR TO LEFT.
3. TO ADJUST DOOR UP OR DOWN

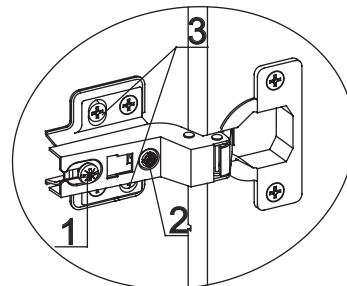

## PACKAGE CONTENT

PART	DESCRIPTION	QUANTITY
A	Cabinet	1
B	Left Back and Right Front Feet	2
C	Left Front and Right Back Feet	2
D	Adjustable Shelf (Pre-attached)	1



**HARDWARE CONTENTS** (shown not actual size)

---

AA



Hex Nut

Qty. 8

BB



5/16" Lock Washer

Qty. 8

CC

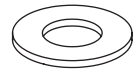

Flat Washer

Qty. 8

DD

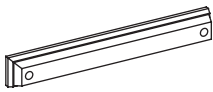

Handle

Qty. 3

EE

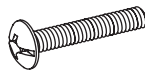

M4 x 28 mm Bolt

Qty. 6

FF



Open Wrench

Qty. 1

GG

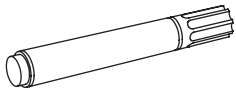

Touch Up Pen

Qty. 1

HH

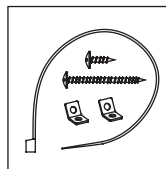

Tipping Restraint  
Hardware

Qty. 1

## **! SAFETY INFORMATION**

---

Please read and understand this entire manual before attempting to assemble or install the product.

1. Please read the Assembly Instructions prior to assembling the unit.
2. To avoid damage, assemble the unit on a sturdy, level and non-abrasive surface.
3. Keep all hardware and parts out of the reach of children.
4. Please wait until all steps are completed before fully tightening bolts.
5. Make sure all bolts and screws are tightly fastened before the unit is used.
6. Check that all bolts, screws are tight at least every 3 months or as needed.

## **! WARNING**

THIS UNIT IS INTENDED FOR USE ONLY WITH THE MAXIMUM WEIGHTS INDICATED. USE WITH PRODUCTS HEAVIER THAN THE MAXIMUM WEIGHTS INDICATED MAY RESULT IN INSTABILITY CAUSING POSSIBLE INJURY. DISTRIBUTE WEIGHT EVENLY.

TOP MAXIMUM:  
45.4kg / 100 lb  
EVENLY DISTRIBUTED.

DRAWER MAXIMUM:  
9.1kg / 20 lb  
EVENLY DISTRIBUTED.

SHELF MAXIMUM:  
22.7kg / 50 lb  
EVENLY DISTRIBUTED.

ENTIRE UNIT MAXIMUM  
WEIGHT CAPACITY:  
77.2kg / 170 lb  
EVENLY DISTRIBUTED

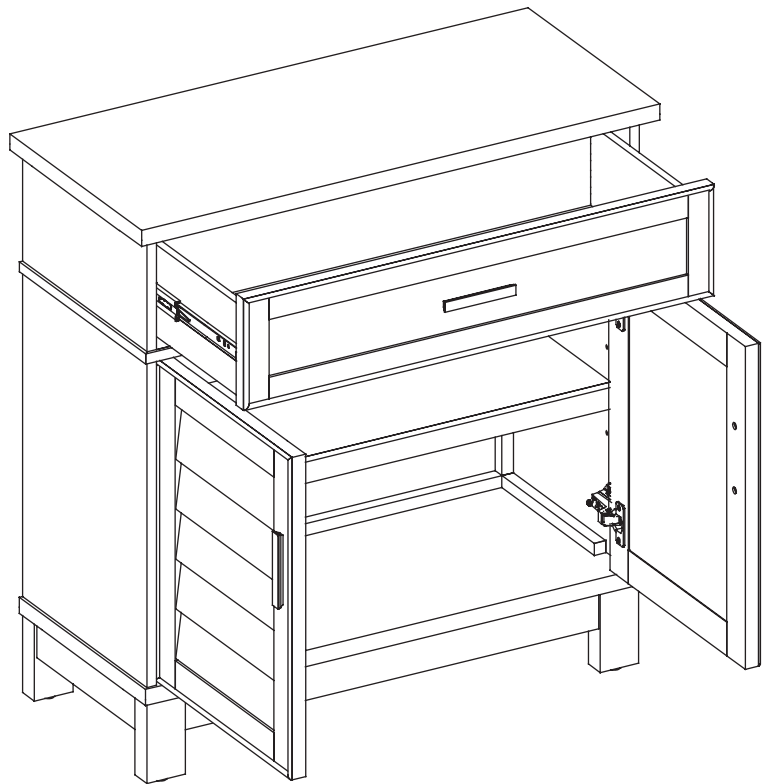

## **PREPARATION**

---

Please read the instruction sheets completely before assembly. Examine all packaging material before discarding carton. Remove any remaining staples from the carton before discarding. Remove all parts from carton and separate into groups as indicated on part list. Please ensure all parts are included prior to assembly. Use of power tools must be with caution and ensuring setting at low-torque, avoid damaging the wood panels.

**Estimated Assembly Time: 30 minutes.**



Tools Required for Assembly (not included): Phillips screwdriver, stud finder, marking pencil, tape measure, power drill and drill bits.

## ASSEMBLY INSTRUCTIONS

1.1 Remove the plastic caps from the hanger bolts on the feet (B and C).

1.2 Inserting the hanger bolts on the feet (B and C) through the drilled holes on the corner block and fit the flat washers (CC), lock washers (BB) and hex nuts (AA) onto each hanger bolt. Securely tighten the nuts with the provided open wrench.

### Hardware Used

<b>AA</b> Hex Nut		x 8
<b>BB</b> 5/16" Lock Washer		x 8
<b>CC</b> Flat Washer		x 8

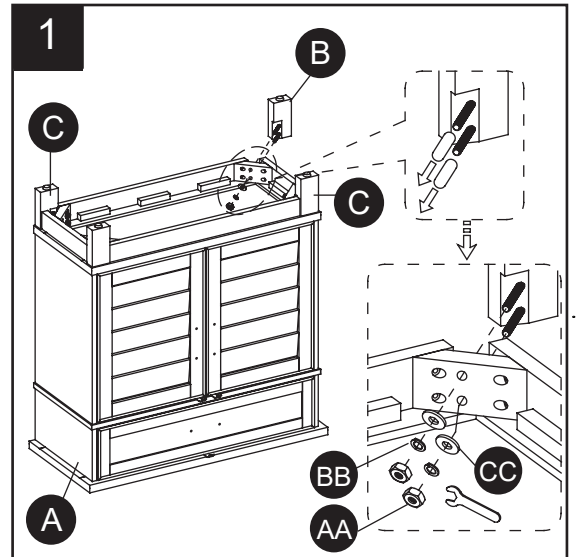

2.1 Ask for assistance to lift the unit upright.

2.2 Open the drawer and install one handle (DD) to the front side of the drawer with two 28mm bolts (EE).

### Hardware Used

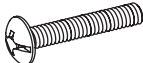
<b>DD</b> Handle		x 1
<b>EE</b> M4 x 28mm Bolt		x 2

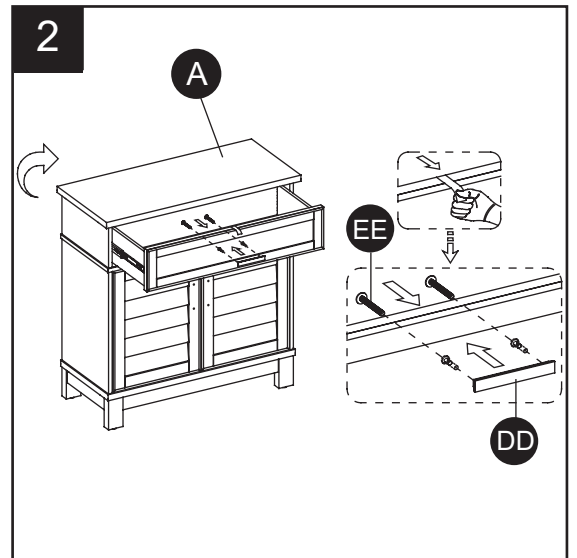

3. Repeat the same process to install one handle (DD) to the front side of each door.

### Hardware Used

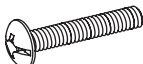
<b>DD</b> Handle		x 2
<b>EE</b> M4 x 28mm Bolt		x 4

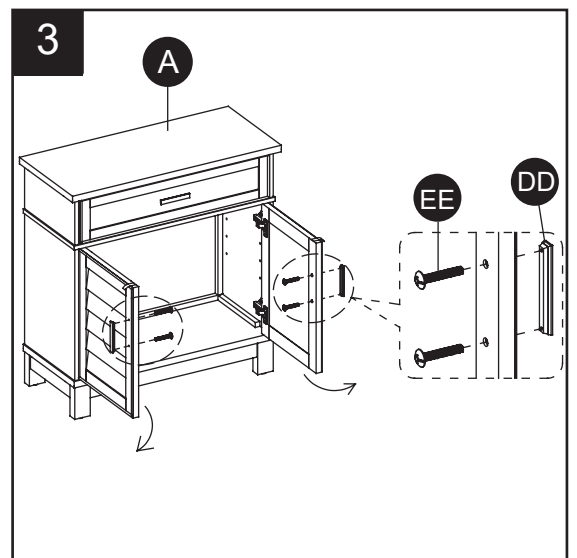

## ASSEMBLY INSTRUCTIONS

4. The adjustable shelf is pre-attached for shipping. If the shelf position is not to your liking, you will need to adjust the shelf supports to the desired location .

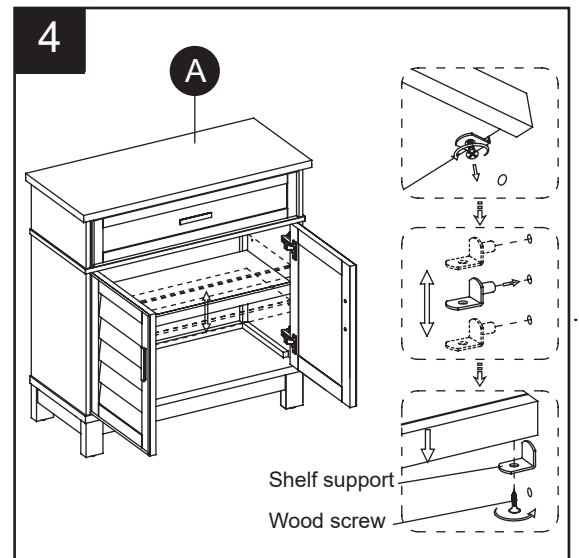

5.1 Position the assembled unit at the desired location against a wall. If necessary, adjust the pre-attached floor levelers by hand to level the doors and correct tilting.  
5.2 Follow the instructions printed on the plastic bag containing the tipping restraint hardware to attach the tipping restraint hardware (HH) to the unit and the wall.

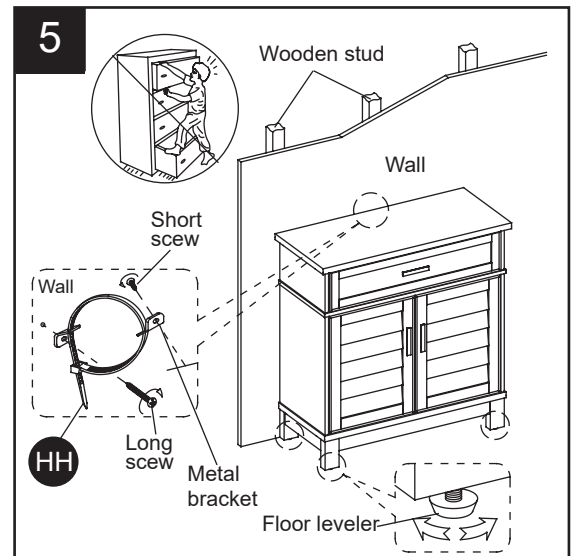

### Hardware Used

HH Tipping restraint hardware

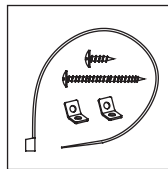

x 1

## **CARE AND MAINTENANCE**

---

- Use a soft, clean cloth that will not scratch the surface when dusting.
- Use of furniture polishes is not necessary. Should you choose to use polishes, test first in an inconspicuous area.
- Using solvents of any kind on your furniture may damage the finish.
- Never use water to clean your furniture as it may cause damage to the finish.
- Always use coasters under beverage glasses and flowerpots.
- Liquid spills should be removed immediately. Using a soft clean cloth, blot the spill gently. Avoid rubbing.
- Always use protective pads under hot dishes and plates. Heat can cause chemical changes that may create spotting within the furniture finish.
- Stains or marks from crayons or ink markers will be difficult to remove.
- In the event that your furniture is stained or otherwise damaged during use, we recommend that you call a professional to repair your furniture.
- Check bolts/nuts periodically and tighten them if necessary.
- Touch-up Pen (GG) has been provided to repair any small nicks or scratches that may occur during assembly or shipping.

## **LIMITED LIFETIME WARRANTY**

---

This product is warranted to the original purchaser. If there is a failure in this unit due to defects in materials or workmanship, the manufacturer will repair or replace this item at our discretion without charge. Warranty is void if product has been assembled incorrectly, misused, abused by overloading, altered in any way or damaged due to accident. This warranty is not transferable and does not cover chipping, flaking, scratches, rust, dents, or other damages to the surfaces of this product. Responsibility of the manufacturer is limited to repair or replacement of this product. The manufacturer is not responsible for consequential, incidental, or other damages or losses resulting from product failure.

This warranty is in lieu of all other expressed warranties. Some states do not allow the exclusion or limitation of incidental or consequential damages, so the above limitation may not apply to you. This warranty gives you specific legal rights and you may have other rights which vary from state to state.



## REPLACEMENT PARTS LIST

---

For replacement parts, call our customer service department at (888) 251-1026, 8 a.m. - 8 p.m., EST, Monday - Sunday. You could also contact us at [partsplus@lowes.com](mailto:partsplus@lowes.com) or visit [www.lowespartsplus.com](http://www.lowespartsplus.com).

PART	DESCRIPTION	PART #
B	Left Back and Right Front Feet	00LWS18AT-B
C	Left Front and Right Back Feet	00LWS18AT-C
D	Adjustable Shelf	00LWS18AT-D
E	Utility Drawer	00LWS18AT-E
F	Drawer Slides (45mm x 10"L)	00LWS18AT-F
G	Left Door	00LWS18AT-G
H	Right Door	00LWS18AT-H
I	European Hinge with Screws	00LWS18AT-I
J	Floor Leveler	00LWS18AT-J
AA	Hex Nut	00LWS18AT-AA
BB	5/16" Lock Washer	00LWS18AT-BB
CC	Flat Washer	00LWS18AT-CC
DD	Handle	00LWS18AT-DD
EE	M4 x 28 mm Bolt	00LWS18AT-EE
FF	Open Wrench	00LWS18AT-FF
GG	Touch Up Pen	00LWS18AT-GG
HH	Tipping Restraint Hardware	00LWS18AT-HH
II	Shelf Support	00LWS18AT-II
JJ	Wood Screw	00LWS18AT-JJ

**REPLACEMENT PARTS LIST**

**B**



**C**



**D**

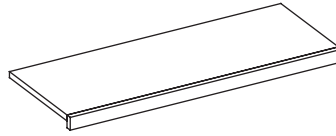

**E**

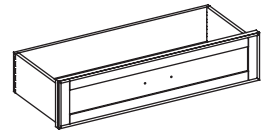

**F**



**G**

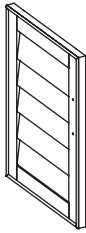

**H**

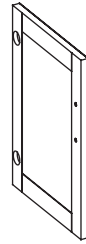

**I**

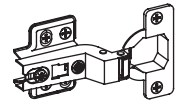

**J**

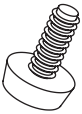

**AA**



**BB**



**CC**

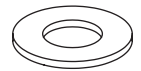

**DD**



**EE**

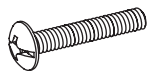

**FF**



**GG**

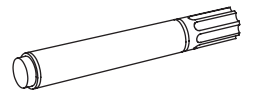

**HH**

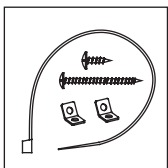

**II**

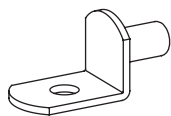

**JJ**



# Origin 21

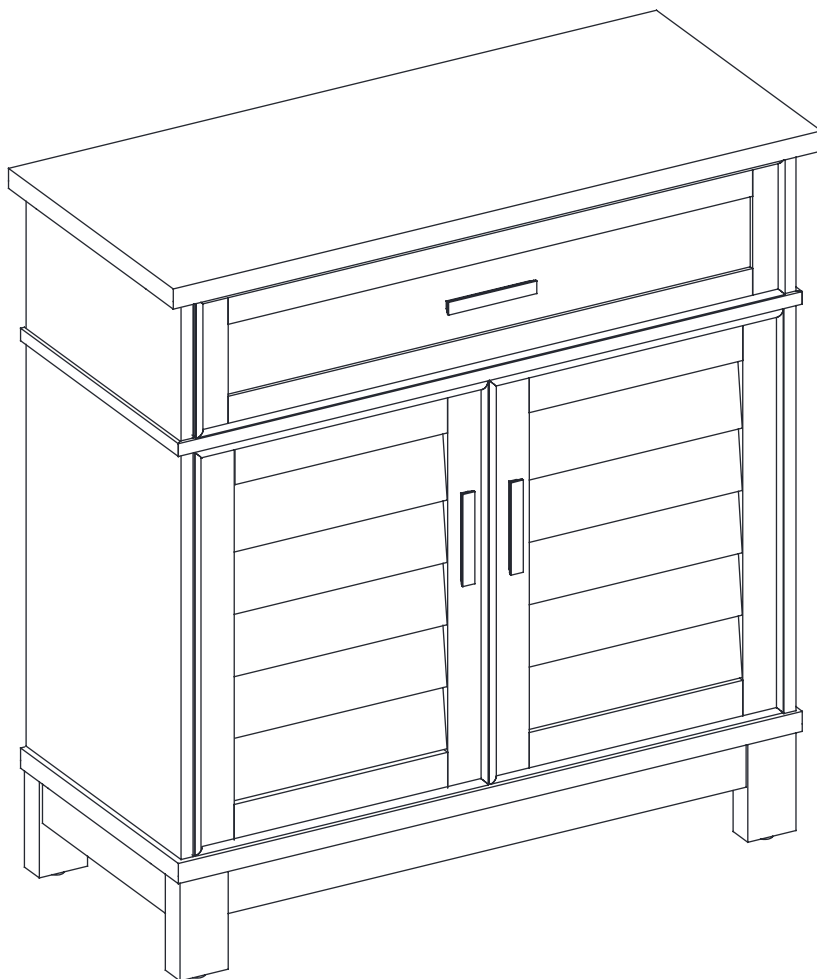

ORIGIN 21 ainsi que le logo sont des marques ou des marques déposées de LF, LLC. Tous droits réservés.

ARTICLE N°4911608

## Table d'Appoint Avec Porte À Lames Bleue

MODÈLE N° LWS18AT

Français p. 11

Español p. 21

### JOINDRE VOTRE REÇU ICI

Numéro de série \_\_\_\_\_ Date d'achat \_\_\_\_\_

**Des questions, des problèmes, des pièces manquantes?** Avant de retourner l'article au détaillant, appelez notre service à la clientèle au (888) 251-1026, entre 8 h et 20 h (HNE), du lundi au dimanche. Vous pouvez également nous contacter à [partsplus@lowes.com](mailto:partsplus@lowes.com).

## **TABLE DES MATIÈRES**

---

Ajustements de charnière.....	2
Contenu de l’emballage.....	3
Contenu de la quincaillerie.....	4
Consignes de sécurité.....	5
Préparation.....	5
Instructions de montage.....	6
Soin et entretien.....	8
Garantie limitée à vie.....	8
Liste des pièces de remplacement. ....	9

## **Ajustements de charnière.**

---

### **Comment ajuster les charnières européennes ajustables sur les portes**

Le transport peut entraîner un désalignement des portes. Si vous estimez que les portes doivent être légèrement ajustées, tournez la vis appropriée, comme illustré.

1. POUR AJUSTER LA PORTE VERS L’AVANT OU L’ARRIÈRE.

2. POUR AJUSTER LA PORTE VERS LA DROITE OU LA GAUCHE.

3. POUR AJUSTER LA PORTE VERS LE HAUT OU LE BAS.

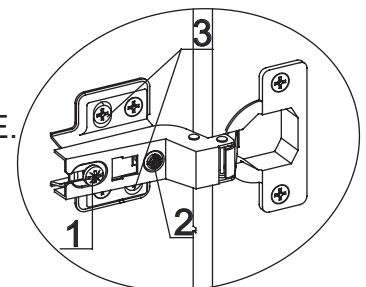

## CONTENU DE L'EMBALLAGE

PIÈCE	DESCRIPTION	QUANTITÉ
A	Armoire	1
B	Pied arrière gauche et pied avant droit	2
C	Pieds avant gauche et pied arrière droit	2
D	Tablette réglable (Déjà fixée)	1



**CONTENU DE LA QUINCAILLERIE (non illustrée à la grandeur réelle)**

---

AA



Écrou hexagonal

Qté. 8

BB



5/16" Rondelle de blocage

Qté. 8

CC



Rondelle plate

Qté. 8

DD



Poignée

Qté. 3

EE

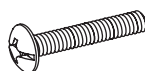

Boulon M4 x 28 mm

Qté. 6

FF



Clé ouverte

Qté. 1

GG

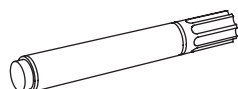

Crayon à retouche

Qté. 1

HH

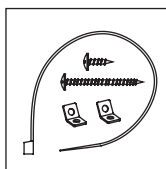

Trousse antibascule

Qté. 1

## **! CONSIGNES DE SÉCURITÉ**

Lire et comprendre le présent guide avant de monter ou d'installer le produit.

1. Lire les Instructions de montage avant d'assembler l'unité.
2. Pour éviter les dommages, assembler l'unité sur une surface solide, de niveau et non abrasive.
3. Garder toute la quincaillerie et les pièces hors de portée des enfants.
4. Attendre que toutes les étapes soient complétées avant de serrer les boulons à fond.
5. S'assurer que tous les boulons et les vis soient solidement fixés avant d'utiliser l'unité.
6. S'assurer tous les trois mois ou au besoin que les boulons, les vis soient solides.

## **! AVERTISSEMENT**

CETTE UNITÉ DOIT ÊTRE UTILISÉE UNIQUEMENT SELON LES POIDS MAXIMAUX INDIQUÉS. L'UTILISATION AVEC DES PRODUITS PLUS LOURDS QUE LES LIMITES MENTIONNÉES PEUT CAUSER DE L'INSTABILITÉ ET DES BLESSURES. RÉPARTIR LE POIDS ÉGALEMENT.

CAPACITÉ MAXIMALE DE  
PANNEAU SUPÉRIEUR :  
45,4kg / 100 lb  
RÉPARTIS ÉGALEMENT.

CAPACITÉ MAXIMALE DE  
TIROIR :  
9,1kg / 20 lb  
RÉPARTIS ÉGALEMENT.

CAPACITÉ MAXIMALE DE  
ÉTAGÈRE :  
22,7kg / 50 lb  
RÉPARTIS ÉGALEMENT.

CAPACITÉ MAXIMALE DE  
L'UNITÉ :  
77,2kg / 170 lb  
RÉPARTIS ÉGALEMENT.

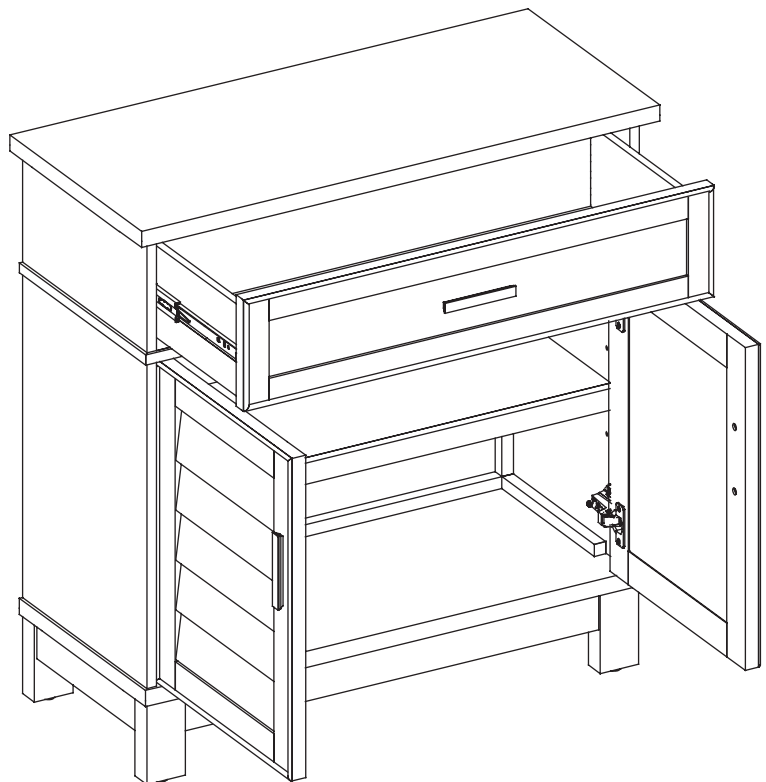

## **PRÉPARATION**

Veillez lire complètement les feuilles d'instruction avant le montage. Examinez tout le matériel d'emballage avant de jeter le carton. Retirez toutes les agrafes restantes du carton avant de le jeter. Retirez toutes les pièces dans le carton, et séparez-les en groupes comme indiqué sur la liste des pièces. Veillez-vous assurer que toutes les pièces sont incluses avant le montage. L'utilisation d'outils électriques doit se faire avec précaution et en veillant à un réglage à faible couple, évitez d'endommager les panneaux de bois.

**Durée approximative du montage : 30 minutes.**



Outils nécessaires pour l'assemblage: tournevis cruciforme, détecteur de montants, crayon, ruban à mesurer, perceuse électrique, foret.

## INSTRUCTIONS DE MONTAGE

1.1 Retirez les capuchons en plastique des boulons de suspension sur le pied.

1.2 Insérez les boulons de suspension sur le pied à travers les trous percés sur le bloc d'angle, et montez les rondelles plate (CC), les rondelles de blocage (BB) et les écrous hexagonaux (AA) sur chaque boulon de suspension. Serrez fermement les écrous avec la clé ouverte fournie.

### Quincaillerie utilisée

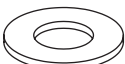

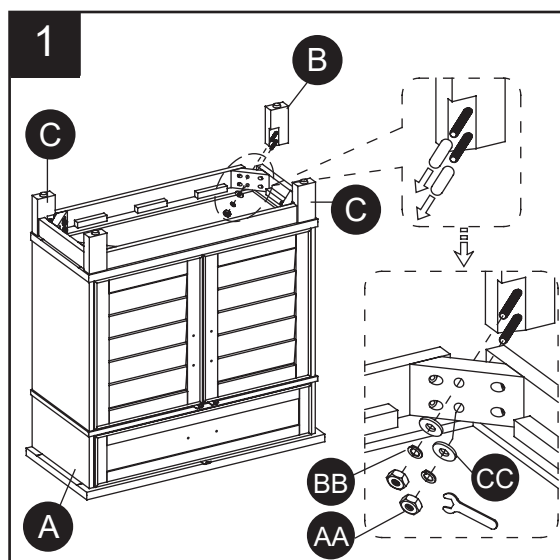
AA	Écrou hexagonal		x 8
BB	5/16" Rondelle de blocage		x 8
CC	Rondelle plate		x 8



2.1 Demandez de l'aide pour soulever l'appareil à la verticale.

2.2 Ouvrez le tiroir et installez une poignée (DD) sur le côté avant du tiroir avec deux boulons de 28 mm (EE).

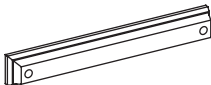
### Quincaillerie utilisée

DD	Poignée		x 1
EE	Boulon M4 x 28mm		x 2

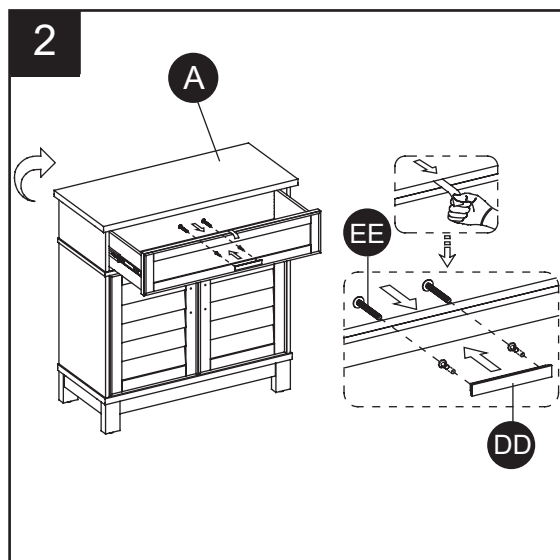

3. Répétez le même processus pour installer une poignée (DD) à l'avant de chaque porte.

### Quincaillerie utilisée

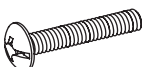
DD	Poignée		x 2
EE	Boulon M4 x 28mm		x 4

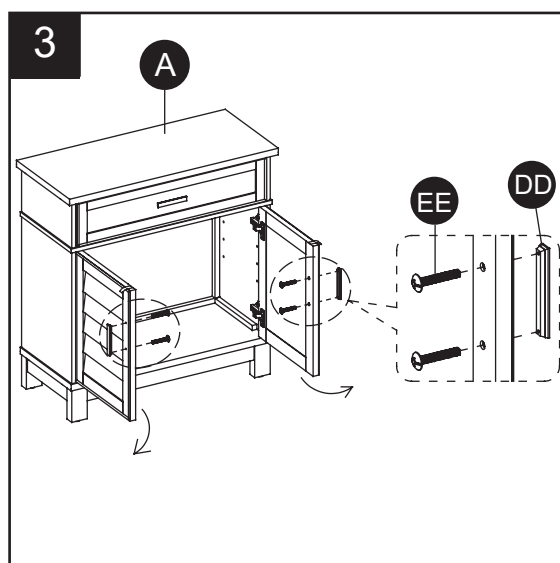



## INSTRUCTIONS DE MONTAGE

4. La tablette réglable est pré-assemblée pour l'expédition. Si la position de la tablette ne vous convient pas, vous devrez ajuster les supports de tablette à l'emplacement souhaité .

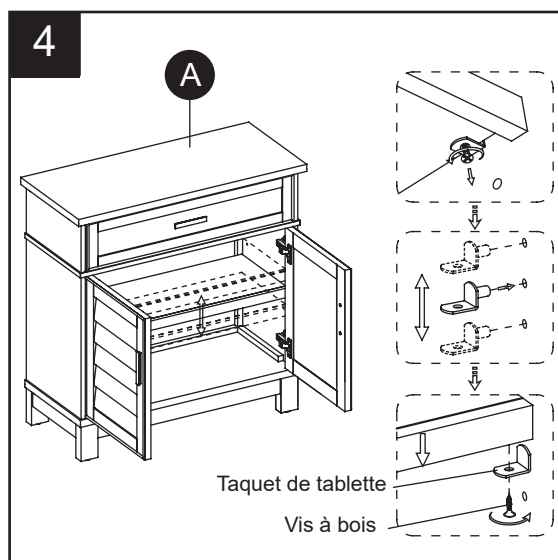

5.1 Placez l'unité assemblée à l'endroit désiré contre un mur. Si nécessaire, ajustez manuellement les niveleurs de sol pré-assemblés pour niveler les portes et corriger l'inclinaison.

5.2 Suivez les instructions imprimées sur le sac en plastique contenant la quincaillerie anti-basculement pour fixer la quincaillerie anti-basculement (HH) à l'appareil et au mur.

### Quincaillerie utilisée

HH Trousse antibascule

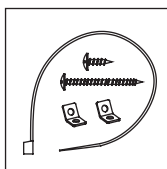

x 1

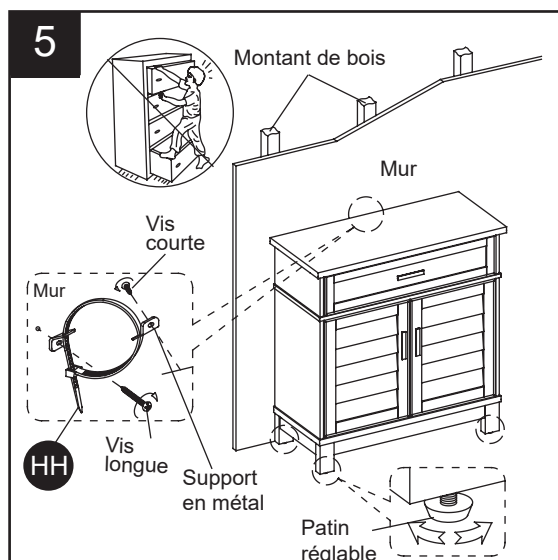

## **SOIN ET ENTRETIEN**

---

- Utiliser un linge doux et propre qui ne rayera pas la surface lors de l'époussetage.
- L'utilisation de poli à meuble n'est pas nécessaire. Le cas échéant, tester d'abord une surface peu visible.
- L'utilisation de solvants de quelque nature que ce soit sur le meuble peut en endommager le fini.
- Ne jamais utiliser d'eau pour nettoyer votre meuble car cela pourrait en endommager le fini.
- Toujours utiliser des sous-verres sous les verres et les pots à fleur.
- Les liquides renversés devraient toujours être retirés sur-le-champ. En utilisant un linge doux et propre, éponger doucement le liquide. Éviter de frotter.
- Toujours utiliser des coussins protecteurs sous les assiettes et les plats chauds. La chaleur peut engendrer des modifications chimiques pouvant créer des taches sur le fini du meuble.
- Les taches et les marques de craies ou de marqueurs à l'encre seront difficiles à retirer.
- Dans le cas où le meuble serait taché ou autrement endommagé lors de l'utilisation, il est recommandé de faire appel à un professionnel pour réparer le meuble.
- Vérifier régulièrement les boulons et les écrous et serrer au besoin.
- Un crayon à retouche (GG) est offert pour réparer toute petite marque ou éraflure pouvant survenir lors du montage ou de l'expédition.

## **GARANTIE LIMITÉE À VIE**

---

Ce produit est garanti à l'acheteur original. En cas de défaut de fabrication ou des matériaux, le fabricant réparera ou remplacera cet article, à sa discrétion, sans frais. La garantie est nulle si le produit a été mal assemblé, utilisé inadéquatement, abusé par la surcharge, modifié de quelque manière que ce soit ou endommagé suite à un accident. La présente garantie n'est pas transférable et ne couvre pas l'écaillage, les éraflures, la rouille, l'enfoncement ni les autres dommages aux surfaces du produit. La responsabilité du fabricant se limite à réparer ou remplacer ce produit. Le fabricant n'est pas responsable des dommages indirects ou accessoires ou de tout autre dommage ou perte résultant d'un bris du produit.

La présente garantie remplace toute autre garantie expresse. Certaines régions ne permettent pas l'exclusion ni la limite des dommages indirects ou accessoires et dans de tels cas, la limite précédente pourrait ne pas s'appliquer. La présente garantie vous donne des recours légaux particuliers et vous pourriez bénéficier d'autres droits qui varient d'une région à l'autre.

## **LISTE DES PIÈCES DE REMPLACEMENT**

Pour obtenir des pièces de rechange, communiquez avec notre service à la clientèle au (888) 251-1026, entre 8 h et 20 h (HNE), du lundi au dimanche. Vous pouvez également nous contacter à [partsplus@lowes.com](mailto:partsplus@lowes.com) ou visiter [www.lowespartsplus.com](http://www.lowespartsplus.com).

<b>PIÈCE</b>	<b>DESCRIPTION</b>	<b>N° DE PIÈCE</b>
B	Pied arrière gauche et pied avant droit	00LWS18AT-B
C	Pieds avant gauche et pied arrière droit	00LWS18AT-C
D	Tablette réglable	00LWS18AT-D
E	Tiroir de rangement	00LWS18AT-E
F	Glissières de tiroir (45mm x 10"L)	00LWS18AT-F
G	Porte gauche	00LWS18AT-G
H	Porte droite	00LWS18AT-H
I	Charnière européenne avec vis	00LWS18AT-I
J	Patin réglable	00LWS18AT-J
AA	Écrou hexagonal	00LWS18AT-AA
BB	5/16" Rondelle de blocage	00LWS18AT-BB
CC	Rondelle plate	00LWS18AT-CC
DD	Poignée	00LWS18AT-DD
EE	Boulon M4 x 28 mm	00LWS18AT-EE
FF	Clé ouverte	00LWS18AT-FF
GG	Crayon à retouche	00LWS18AT-GG
HH	Trousse antibascule	00LWS18AT-HH
II	Taquet de tablette	00LWS18AT-II
JJ	Vis à bois	00LWS18AT-JJ

# LISTE DES PIÈCES DE RECHANGE

B



C



D

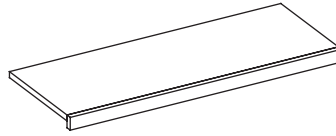

E

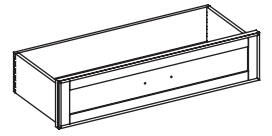

F



G

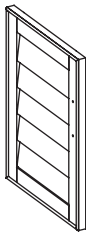

H

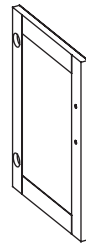

I

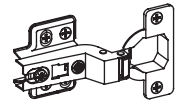

J

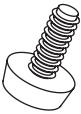

AA



BB



CC

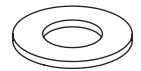

DD

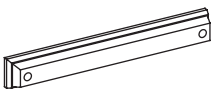

EE

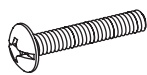

FF



GG

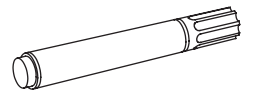

HH

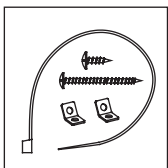

II

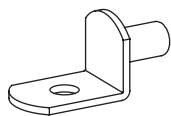

JJ



Date: 2022-02-08 Rév. 0001-A

Imprimé au Vietnam

# Origin 21

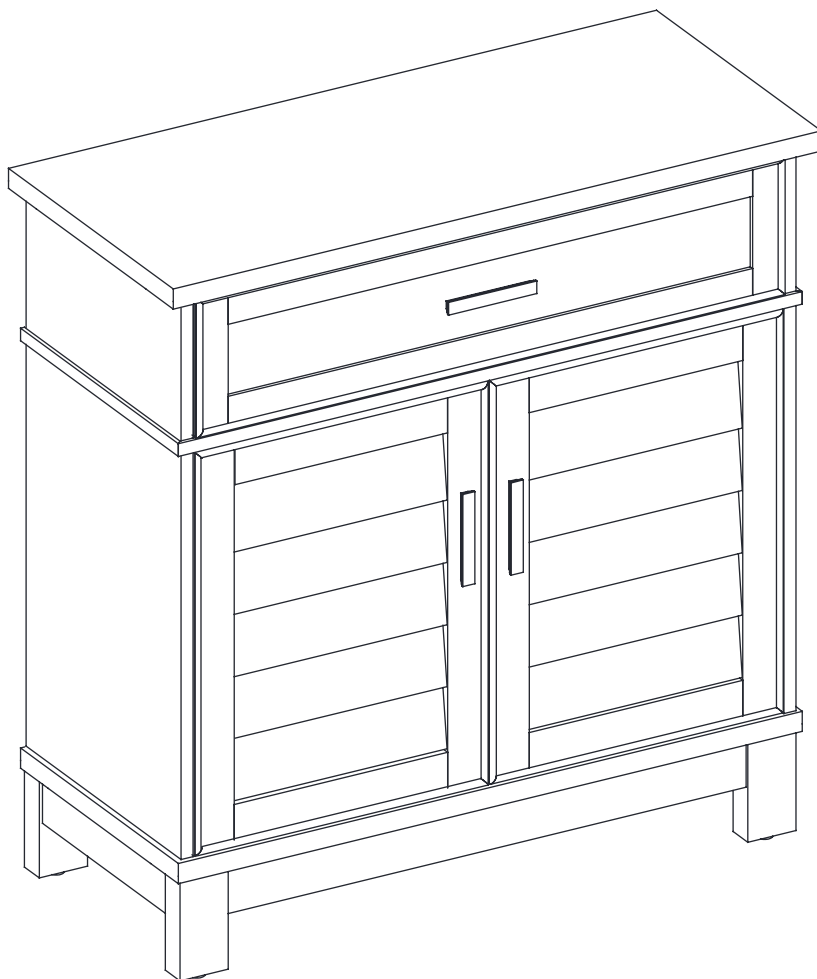

ORIGIN 21 y el diseño del logotipo son marcas comerciales o marcas registradas de LF, LLC. Todos los derechos reservados.

ARTÍCULO #4911608

## Mesa de puerta en tablillas azul

MODELO #LWS18AT

Français p. 11

Español p. 21

### ADJUNTAR SU RECIBO AQUÍ

Número de serie \_\_\_\_\_ Fecha de compra \_\_\_\_\_

**¿Preguntas, problemas, piezas faltantes?** Antes de volver a la tienda, llame a nuestro Departamento de Servicio al Cliente al (888) 251-1026, de lunes a domingo de 8 a.m. a 8 p.m., hora estándar del Este. También puedes ponerte en contacto con nosotros en [partsplus@lowes.com](mailto:partsplus@lowes.com).

## TABLAS DE CONTENIDOS

---

Ajustes de bisagra.....	2
Contenido del paquete.....	3
Contenido de herraje.....	4
Información de seguridad.....	5
Preparación .....	5
Instrucciones de ensamblaje.....	6
Cuidado y mantenimiento.....	8
Garantía limitada.....	8
Lista de piezas de repuesto.....	9

## Ajustes de bisagra

---

### Como ajustar las bisagras Europeas ajustables en las puertas

El envío puede causar que las puertas se desalineen. Si encuentra que las puertas necesitan una ajustada, gire el perno apropiado, como esta ilustrado.

1. PARA AJUSTAR LA PUERTA HACIA ADELANTE O HACIA ATRAS.
2. PARA AJUSTAR LA PUERTA HACIA LA DERECHA O HACIA LA IZQUIERDA.
3. PARA AJUSTAR LA PUERTA HACIA ARRIBA O HACIA ABAJO.

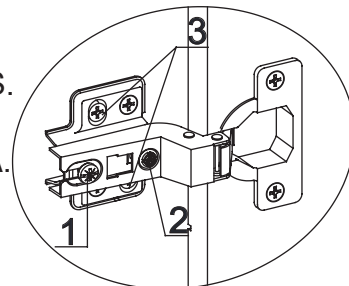

## CONTENIDO DEL PAQUETE

PARTE	DESCRIPCIÓN	CANTIDAD
A	Gabinete	1
B	Patas izq. post. y der. frontal	2
C	Patas izq. frontal y der. post.	2
D	Repisa ajustable (Pre-adjunta)	1



**CONTENIDO DE FERRETERÍA** (no mostradas en tamaño real)

---

AA



Tuerca hexagonal

Cant. 8

BB



5/16" Arandela de presión

Cant. 8

CC

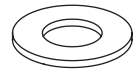

Arandela Plana

Cant. 8

DD

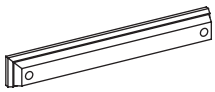

Manija

Cant. 3

EE

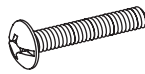

Perno de M4 x 28 mm

Cant. 6

FF



Llave española

Cant. 1

GG

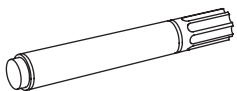

Plumón de retoque

Cant. 1

HH

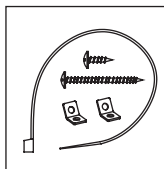

Juego de restricción de movimiento

Cant. 1



## **! INFORMACIÓN DE SEGURIDAD**

Por favor lea y comprenda el manual entero antes de intentar ensamblar o instalar el producto.

1. Por favor, lea las instrucciones de ensamble antes de usar la unidad.
2. Para evitar daños, ensamble la unidad sobre una superficie firme, nivelada y no abrasiva. Mantenga todos los accesorios y las piezas fuera del alcance de los niños
3. Espere hasta que se completen todos los pasos antes de apretar completamente los tornillos.
4. Asegúrese de que todos los pernos y tornillos estén bien apretados antes de utilizar la unidad.
5. Verifique que todos los pernos, tornillos estén apretados por lo menos cada 3 meses o cuando sea necesario.

## **! ADVERTENCIA**

ESTÁ UNIDAD ESTÁ DISEÑADA PARA USO ÚNICAMENTE CON LOS PESOS MÁXIMOS INDICADOS. USO CON CARGAS MAYORES DE LOS PESOS MÁXIMOS INDICADOS PUEDE RESULTAR EN INESTABILIDAD, CAUSANDO POSIBLES LESIONES.

CAPACIDAD MÁXIMA DE  
LA PANEL SUPERIOR:  
45.4kg / 100 libras  
DISTRIBUIDOS  
UNIFORMEMENTE.

CAPACIDAD MÁXIMA DE  
LA CAJÓN:  
9.1kg / 20 libras  
DISTRIBUIDOS  
UNIFORMEMENTE.

CAPACIDAD MÁXIMA DE  
LA REPISA:  
22.7kg / 50 libras  
DISTRIBUIDOS  
UNIFORMEMENTE.

CAPACIDAD MÁXIMA DE  
LA UNIDAD COMPLETA:  
77.2kg / 170 libras  
DISTRIBUIDOS  
UNIFORMEMENTE

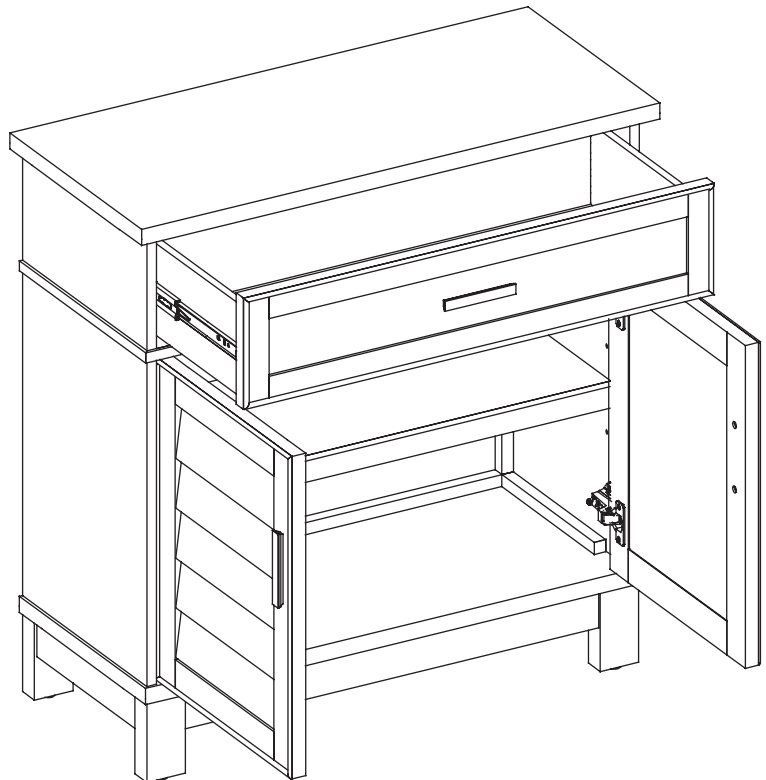

## **PREPARACIÓN**

Antes de empezar el ensamble del producto, asegúrese de que todas las partes estén presentes. Compare las piezas con el contenido en la lista de partes del paquete y el diagrama de arriba. Si alguna parte falta o está dañada, no intente ensamblar el producto. Póngase en contacto con servicio al cliente para las piezas de reemplazo.

**Tiempo estimado de ensamble: 30 minutos.**



Herramienta requerida para el ensamble: destornillador phillips, detector de vigas, lápiz para marcar, cinta métrica, taladro eléctrico, broca.

## INSTRUCCIONES DE ENSAMBLAJE

1.1 Retirar las tapas de plástico de los pernos colgantes en las patas (B y C).

1.2 Insertar los pernos colgantes en las patas (B y C) a través de los agujeros perforados en el bloque de esquina y meter las arandelas planas (CC), las arandelas de presión (BB) y las tuercas hexagonales (AA) sobre cada perno colgante. Apretar las tuercas con la llave española provista.

### Herraje Utilizado

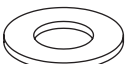

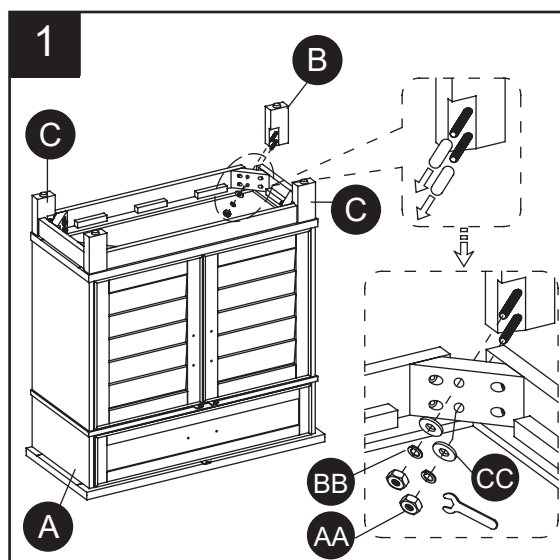
<b>AA</b>	Tuerca hexagonal		x 8
<b>BB</b>	5/16" Arandela de presión		x 8
<b>CC</b>	Arandela Plana		x 8



2.1 Pedir asistencia para poner la unidad en posición vertical.

2.2 Abrir el cajón e instalar una manija (DD) al frente del cajón con 2 pernos de 28mm (EE).

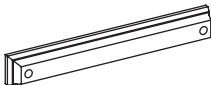
### Herraje Utilizado

<b>DD</b>	Manija		x 1
<b>EE</b>	Perno de M4 x 28mm		x 2

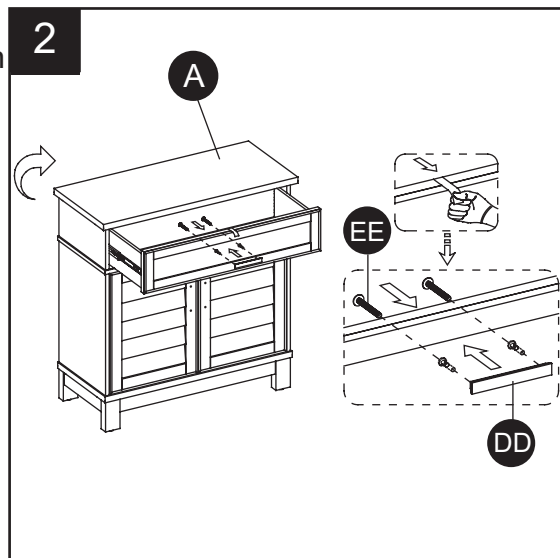

3. Repetir el mismo proceso para instalar una manija (DD) al frente de cada puerta.

### Herraje Utilizado

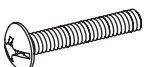
<b>DD</b>	Manija		x 2
<b>EE</b>	Perno de M4 x 28mm		x 4

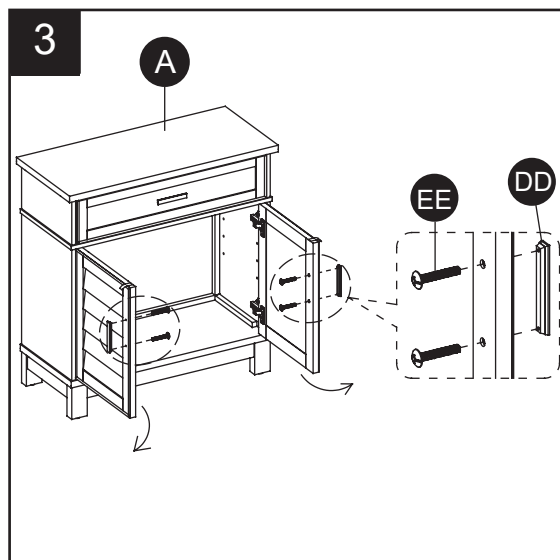

## INSTRUCCIONES DE ENSAMBLAJE

4. La repisa ajustable esta pre-adjuntada para el envío. Si la posición de la repisa no está a su gusto, necesitara ajustar los soportes de repisa al lugar deseado.

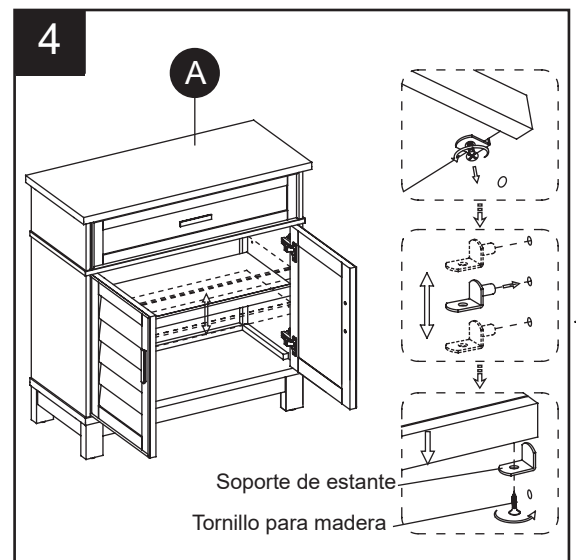

5.1 Poner la unidad ensamblada en el lugar deseado contra la pared. Si fuera necesario, ajustar los niveladores de piso pre-adjuntados manualmente para nivel de puertas y corregir la inclinación.

5.2 Siga las instrucciones imprimidas en la bolsa de plástico que contiene el juego de restricción de movimiento para adjuntar los topes de movimientos (HH) a la unidad y pared.

### Herraje Utilizado

HH Juego de restricción de movimiento

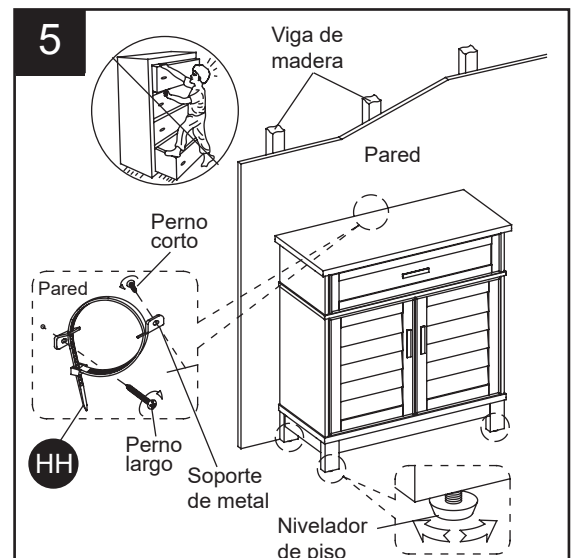
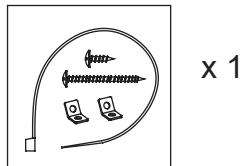

## **CUIDADO Y MANTENIMIENTO**

---

- Utilice un paño suave y limpio para que no se raye la superficie cuando limpie el polvo
- El uso de ceras para muebles no es necesario. Si decide utilizar ceras, checar un área poco visible.
- Uso de disolventes de cualquier tipo en sus muebles puede dañar el terminado.
- Nunca utilice agua para limpiar sus muebles, ya que puede causar daños al terminado.
- Utilice siempre toallas bajo vasos de bebidas.
- Los derrames de líquidos deben ser retirados inmediatamente. Con un paño suave y limpio, seque el derrame suavemente. Evitar frotar.
- Siempre use almohadillas protectoras en platos calientes. El calor puede causar cambios químicos que pueden crear manchas en los muebles.
- Las manchas o marcas de crayones o marcadores de tinta difícil para eliminar.
- En el caso de que sus muebles se tiñe o dañado durante el uso, se recomienda que llame a un profesional para reparar sus muebles.
- Revise los tornillos/tuercas periódicamente y apretar si es necesario.
- Plumón de retoque (GG) se ha proporcionado para reparar los pequeños rasguños o arañazos que pueden ocurrir durante montaje o envío.

## **GARANTIA LIMITADA**

---

Este producto (con exclusión de las repisas) está garantizado para el comprador original. Si hay un fallo en esta unidad debido a defectos en los materiales o mano de obra, el fabricante reparará o reemplazará esta unidad a nuestra discreción y sin cargo alguno. La garantía queda anulada si el producto ha sido ensamblado incorrectamente, utilizado incorrectamente por la sobrecarga, de alguna forma alterada o dañada debido a un accidente. Esta garantía no es transferible y no cubre astillado, descamación, arañazos, óxido, abolladuras u otros daños a las superficies de este producto. La responsabilidad del fabricante se limita a la reparación o sustitución de este producto. El fabricante no es responsable de daños consecuentes, incidentales o de otra, o pérdidas resultantes de la falla del producto.

Esta garantía está en lugar de cualquier otra garantía expresa. Algunos estados no permiten la exclusión o limitación de daños incidentales o consecuentes, por lo que la limitación anterior puede no ser aplicable en su caso. Esta garantía le otorga derechos legales específicos y usted puede tener otros derechos que varían de estado a estado.

## LISTA DE PIEZAS DE REPUESTO

Para obtener piezas de repuesto, llame a nuestro Departamento de Servicio al Cliente al (888) 251-1026, de lunes a domingo de 8 a.m. a 8 p.m., hora estándar del este. También puedes ponerte en contacto con nosotros en [partsplus@lowes.com](mailto:partsplus@lowes.com) o visitar [www.lowespartsplus.com](http://www.lowespartsplus.com).

PIEZA	DESCRIPCIÓN	PARTE #
B	Patas izq. post. y der. frontal	00LWS18AT-B
C	Patas izq. frontal y der. post.	00LWS18AT-C
D	Repisa ajustable	00LWS18AT-D
E	Cajón de utilitario	00LWS18AT-E
F	Deslizadera del cajón (45mm x 10"L)	00LWS18AT-F
G	Puerta izquierda	00LWS18AT-G
H	Puerta derecha	00LWS18AT-H
I	Bisagra europea con pernos	00LWS18AT-I
J	Nivelador de piso	00LWS18AT-J
AA	Tuerca hexagonal	00LWS18AT-AA
BB	5/16" Arandela de presión	00LWS18AT-BB
CC	Arandela plana	00LWS18AT-CC
DD	Manija	00LWS18AT-DD
EE	Perno de M4 x 28 mm	00LWS18AT-EE
FF	Llave española	00LWS18AT-FF
GG	Plumón de retoque	00LWS18AT-GG
HH	Juego de restricción de movimiento	00LWS18AT-HH
II	Soporte de estante	00LWS18AT-II
JJ	Tornillo para madera	00LWS18AT-JJ

# LISTA DE PIEZAS DE REPUESTO

B



C



D

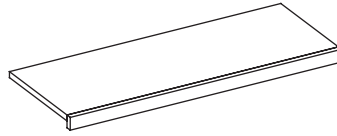

E

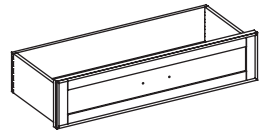

F



G

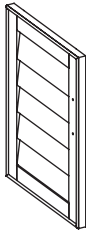

H

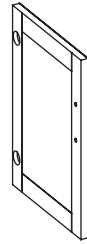

I

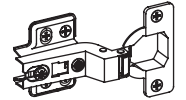

J

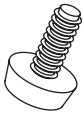

AA



BB



CC

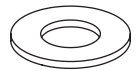

DD



EE

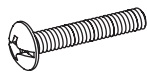

FF



GG

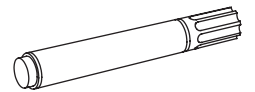

HH

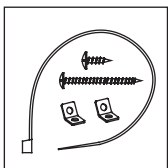

II

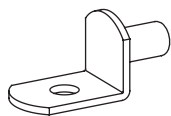

JJ



Fecha: 2022-02-08 Rev. 0001-A

Impreso en Vietnam