

Assembly Instructions & User' s Manual

for

Stetson Writing Desk

Model Number: SMSSDSK-NTL / SMSSDSK-BLK

Customer Assistance (spare/replacement parts): 1-866-942-5362

or Email: parts@whalenfurniture.com

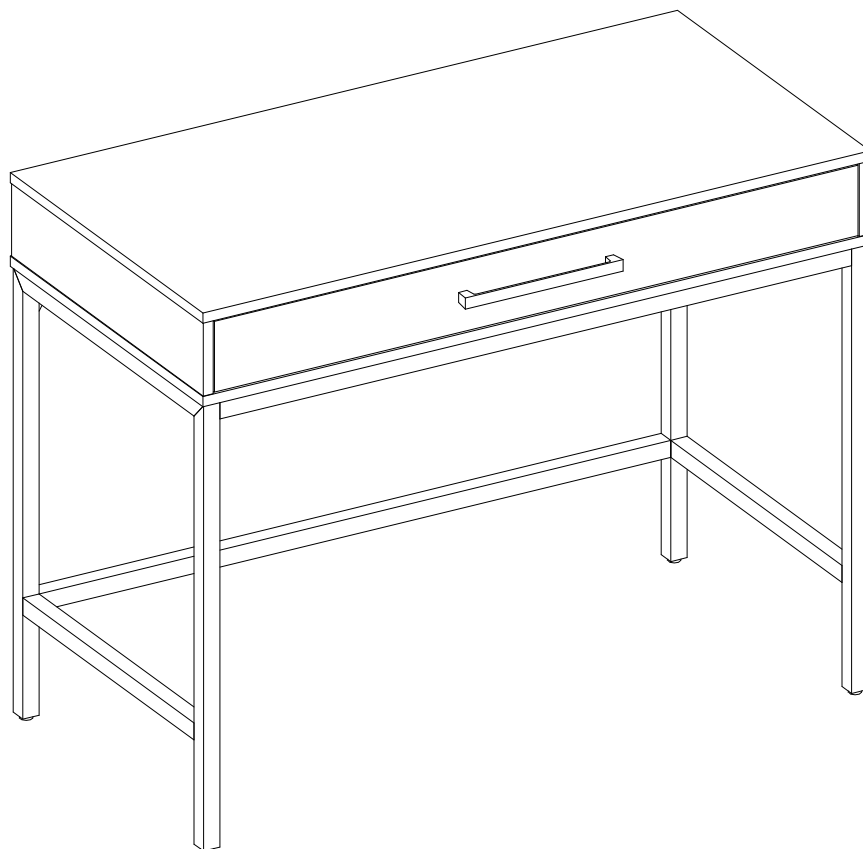

LOT NUMBER: _____ DATE PURCHASED: ___/___/_____

THIS ASSEMBLY MANUAL CONTAINS **IMPORTANT** SAFETY INFORMATION.
PLEASE READ AND KEEP FOR FUTURE REFERENCE.

Table of Contents

Quality Statement.....	3
Important Safety Information	3
Before Assembly	3
Care & Use	3
Package Contents	4
Product Information	4
Components	4
Hardware	5
Tools	5
Step 1	6
Step 2	7
Step 3	8
Step 4	9
Troubleshooting	10
Care & Use Instructions	10
Warranty Information	10

Quality Statement

Questions or Comments?

We would love to hear about your experience! Visit us at:
www.whalenstyle.com

Important Safety Information

- *Please read all instructions carefully before assembling this product.*
- *Where applicable, and for your safety, assembly by an adult is strongly recommended.*
- *Use only vendor-supplied hardware to assemble this item. Using unauthorized hardware could jeopardize the structural integrity of the item.*
- *Hardware may loosen overtime. Periodically check that all connections are tight.*

Before Assembly

- *Remove all parts and hardware from the box. Place all items on a carpeted or scratch-free work surface, as this will avoid damaging parts during assembly.*
- *The shipping box can provide an ideal work surface if none is available.*
- *Use the components and hardware lists below to identify, inventory and separate each of the hardware and components included.*
- *To avoid accidentally discarding small components or hardware, do not dispose of any packaging or contents of the shipping carton until assembly is complete.*
- **DO NOT USE** *power tools unless it is explicitly identified in this manual as required for use during assembly. Power tools can damage the fasteners, hardware and/or components.*
- *Do not fully tighten all fasteners / screws until all parts are in place. Failure to follow these instructions may cause the fasteners / screws to misalign during assembly.*

Care & Use

- *Use a soft, clean cloth that will not scratch the surface when dusting.*
- *Use of furniture polish is not necessary. Should you choose to use polish, test first in an inconspicuous area.*
- *Using solvents of any kind on your furniture may damage the finish.*
- *Never use water to clean your furniture as it may cause damage to the finish.*
- *Liquid spills should be removed immediately. Using a soft, clean cloth, blot the spill gently. Avoid rubbing.*
- *Do not place furniture in direct sunlight.*

Package Contents

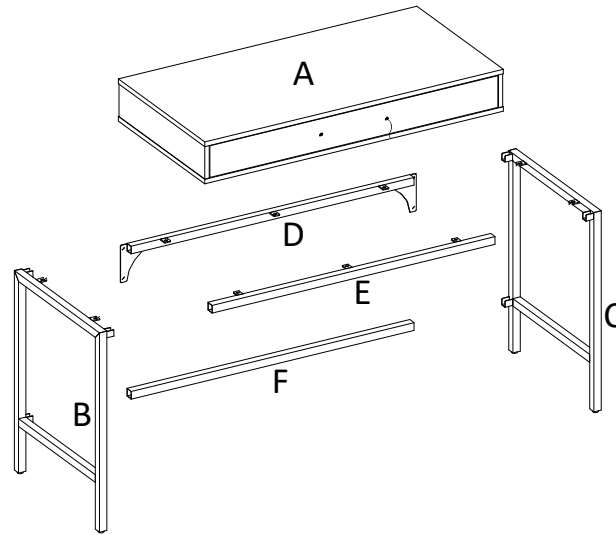

Component	Description	Quantity	Component	Description	Quantity
A	Desk Top	1	D	Upper Back Stretcher	1
B	Left Side Frame	1	E	Upper Front Stretcher	1
C	Right Side Frame	1	F	Lower Back Stretcher	1

Product Information

Dimensions – **40” W x 20.75” D x 31.25” H (101.6cm W x 52.7cm D x 79.3cm H)**



Weight Capacity –Desk Top: 90.8 kg / 200 lb

Drawer: 9.1 kg / 20 lb

Components

Component A Part No.00SMSSDSK-BLK-A 00SMSSDSK-NTL-A Qty. 1	Component B Part No.00SMSSDSK-BLK-B 00SMSSDSK-NTL-B Qty. 1	Component C Part No.00SMSSDSK-BLK-C 00SMSSDSK-NTL-C Qty. 1
Component D Part No.00SMSSDSK-BLK-D 00SMSSDSK-NTL-D Qty. 1	Component E Part No.00SMSSDSK-BLK-E 00SMSSDSK-NTL-E Qty. 1	Component F Part No.00SMSSDSK-BLK-F 00SMSSDSK-NTL-F Qty. 1

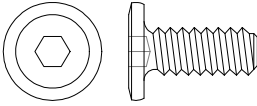
Hardware

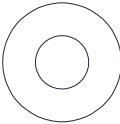
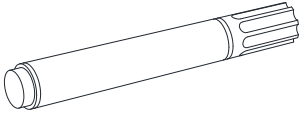
<p>1/4" x 15mm Bolt (H1) Qty. 20+1 extra</p>	<p>Lock Washer (H2) Qty. 20+1 extra</p>
	
<p>Flat Washer (H3) Qty. 20+1 extra</p>	<p>Touch-up Pen (H4) Qty. 1</p>
	

Tools

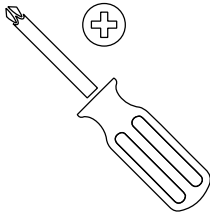
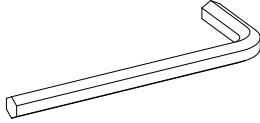
<p>Phillips Screwdriver (Not included)</p>	<p>Hex Wrench (H5) (Included) Qty. 1</p>
	

Step 1

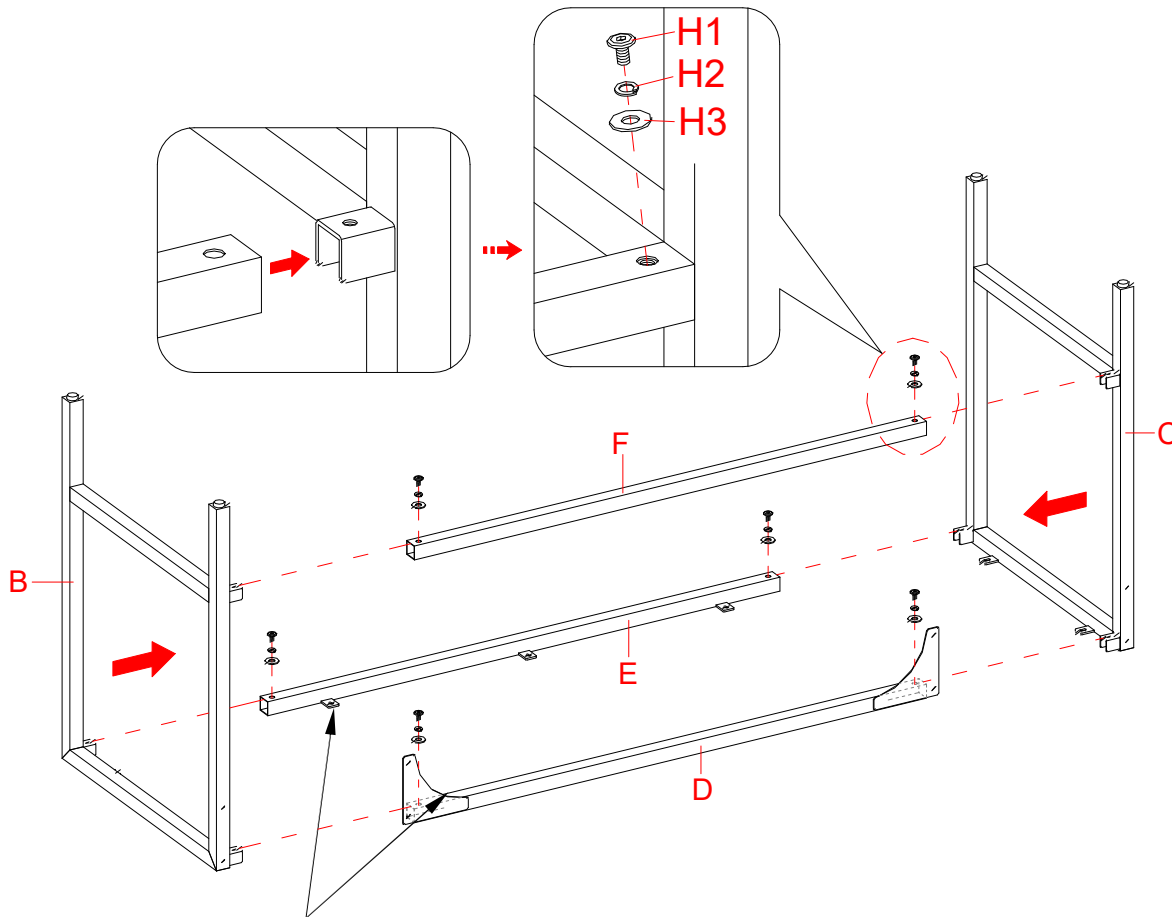
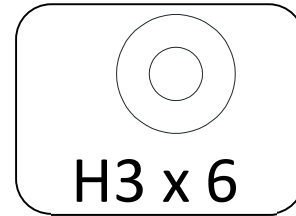
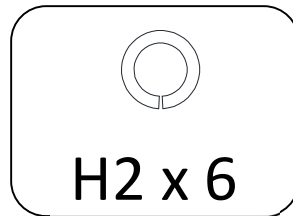
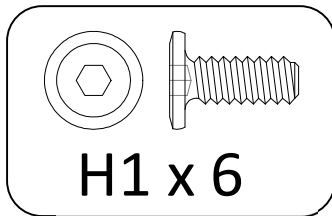

The metal tabs face inward and are located at up when the unit is turned upright.

- Unpack the units and confirm that you have all hardware and required parts.
- Orient and fit both Upper Stretchers (D and E) and Lower Back Stretcher (F) onto the U-shaped brackets on the Left Side Frame (B) with the holes aligned. Fasten them into place with three 15mm Bolts (H1) and the Washers (H2 and H3). Tighten the bolts with the provided hex wrench.
- Repeat the same procedure to attach the Right Side Frame (C) at the other end.

Step 2

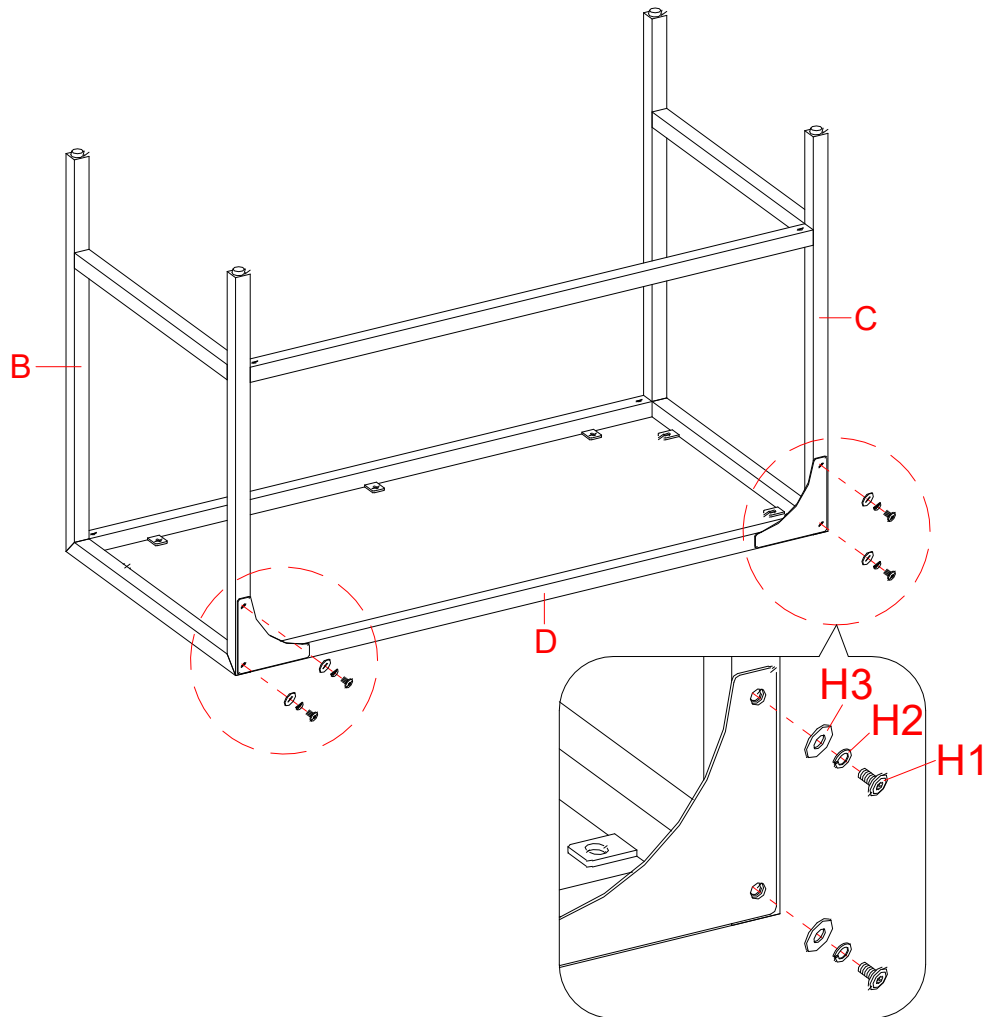
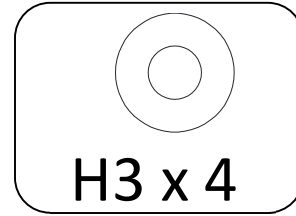
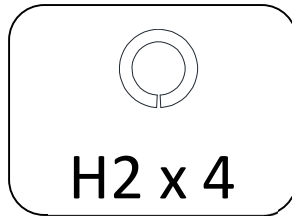
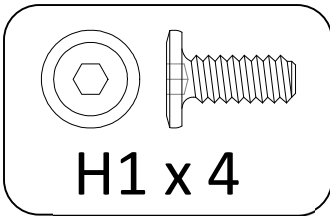

- a) Insert four 15mm Bolts (H1) with the Washers (H2 and H3) through the metal plates on the Upper Back Stretcher (D) and securely screw into the threaded sockets on both Side Frames (B and C).

Step 3

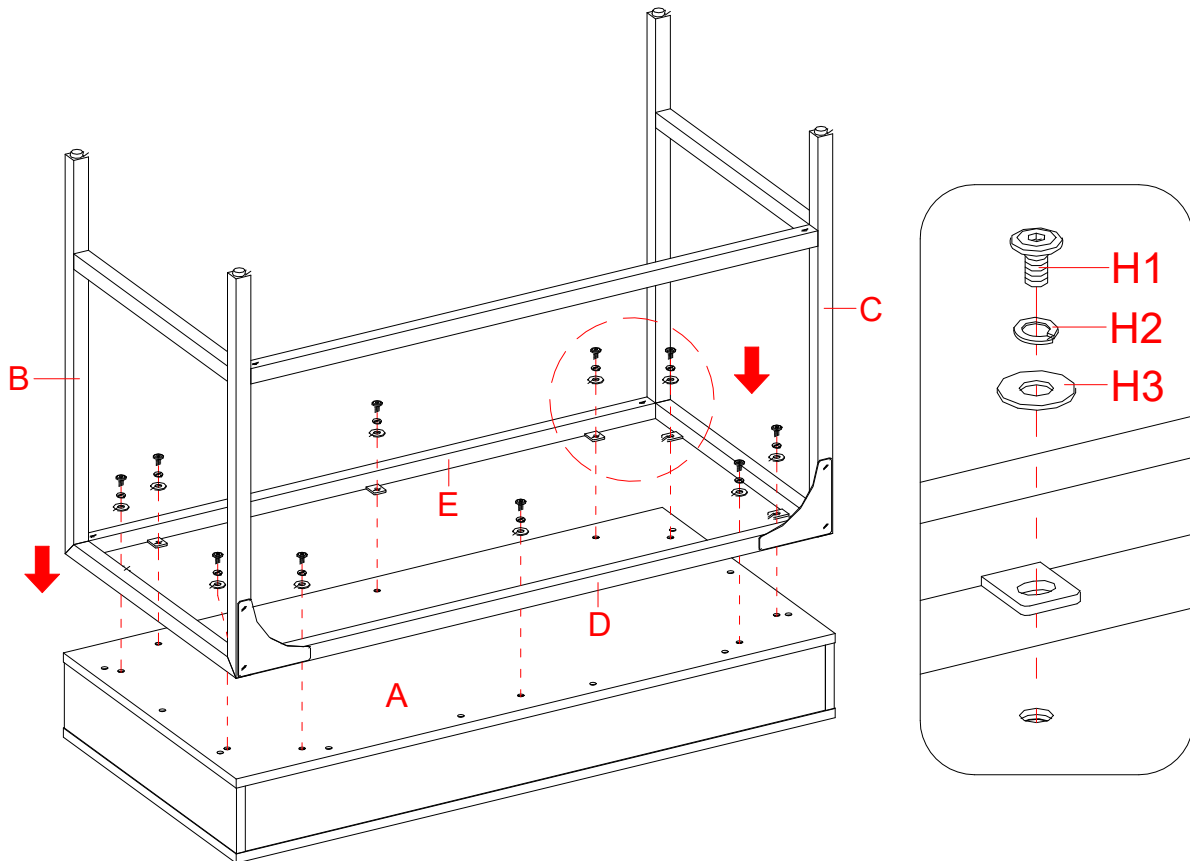
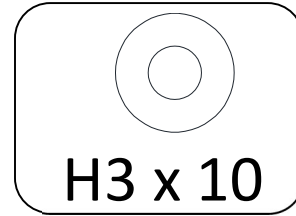
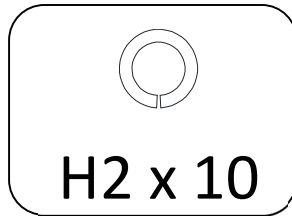
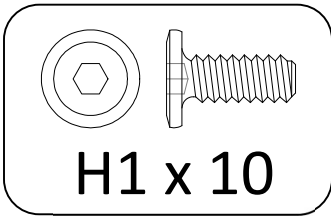

- Position the Desk Top (A) upside down on a level and protected surface as shown.
- Align the assembled base to the Desk Top (A) properly and insert ten 15mm Bolts (H1) with Washers (H2 and H3) through the metal tabs and screw into the threaded inserts on the Desk Top (A).
- Now, go back and securely tighten all the bolts. Make sure all the parts are tight and there are no gaps between the parts. This will help keep the unit square.

Step 4

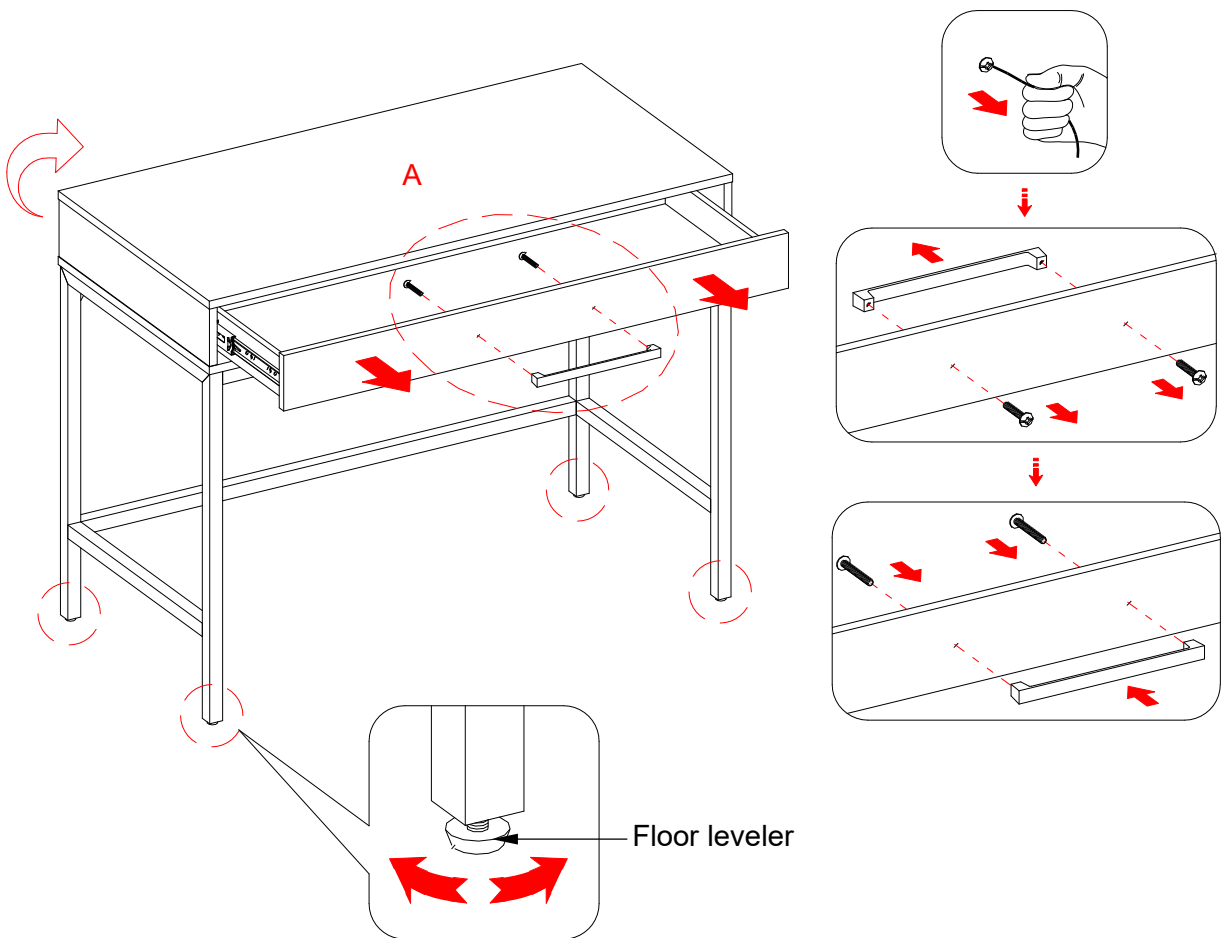

- Lift the assembled unit upright and position it near the final location.
- The drawer comes with the handle pre-assembled to the inside of utility drawer. To remove the handle, unscrew the bolts located on the front of the drawer. Re-install the handle to the front of the utility drawer with the same bolts.
- If necessary, adjust the pre-attached floor levelers at the bottom of the side frames (B and C) to correct the tilting.

Troubleshooting

Problem	Possible Cause	Prevention / Solution
Tilting / wobbling	Surface not level	Adjust the floor levelers
Scratches / Nicks	Assembly or shipping damage	Use touch-up pen to cover

Care & Use Instructions

Care	Do not expose the furniture to direct sunlight, drying heat sources or dampness.
	Use products specifically made for cleaning wood. Use a wood conditioning cleaner that does not contain waxes or silicones (test the product in an invisible location first).
Use	Periodically check to make certain all components are properly positioned, free from damage and firmly connected.
	Check bolts/screws periodically and tighten them if necessary.
	In the event that your furniture is stained or otherwise damaged during use, we recommend that you call a professional to repair your furniture.
	Liquid spills should be removed immediately. Using a soft, clean cloth, blot the spill gently. Avoid rubbing.
	Never use water to clean your furniture as it may cause damage to the finish.
Using solvents of any kind on your furniture may damage the finish.	

Warranty Information

This product component has a (1) year guarantee against defects in material and/or workmanship. If you have any questions regarding the warranty or spare / replacement parts, please call our toll-free number **1-866-942-5362** or email us at parts@whalenfurniture.com

NOTE: Please consider recycling all applicable packaging material.

Whalen Furniture Manufacturing
1578 Air Wing Road, San Diego, CA 92154, USA
8:30 a.m. - 4:30 p.m., PST, Monday to Friday
www.whalenstyle.com

Instrucciones de ensamble & manual del usuario

para

Escritorio Stetson

Número del modelo: SMSSDSK-NTL / SMSSDSK-BLK

Asistencia al cliente (partes extras/de repuesto): 1-866-942-5362

o Email: parts@whalenfurniture.com

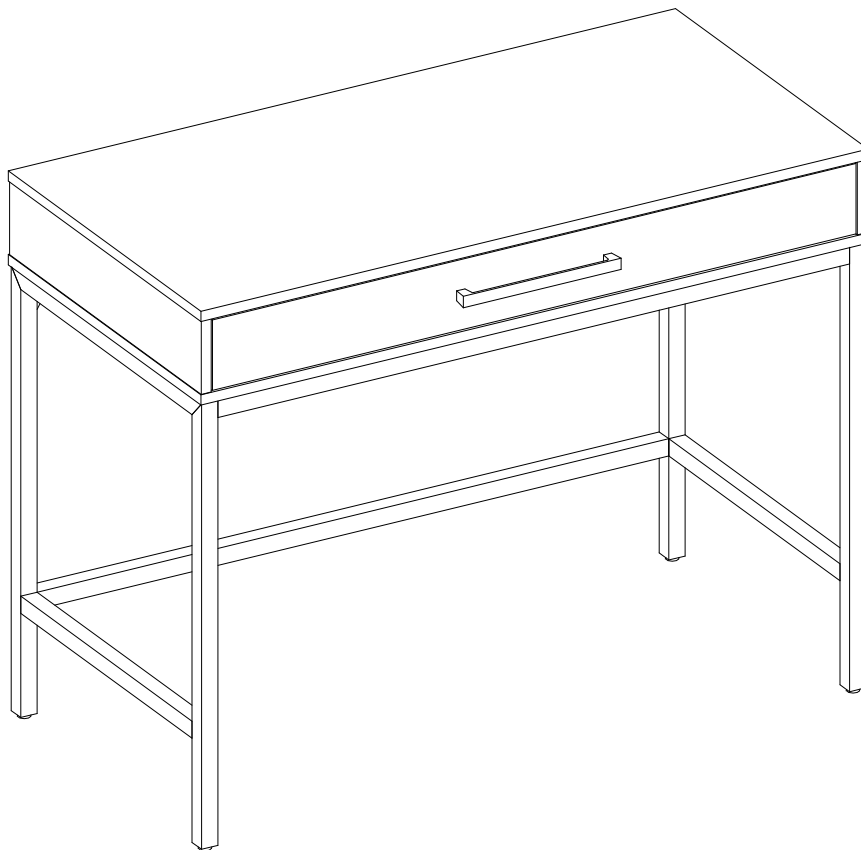

NÚMERO de LOTE: _____ FECHA de COMPRA: __/__/_____

ESTÉ INSTRUCTIVO CONTIENE INFORMACIÓN DE SEGURIDAD **IMPORTANTE**
POR FAVOR LEA Y MANTENGA PARA USO FUTURO.

Tabla de contenido

Declaración de calidad	3
Información de seguridad importante	3
Antes del ensamble	3
Cuidado & uso	3
Contenidos del paquete	4
Información del producto	4
Componentes	4
Material de ferretería	5
Herramientas	5
Paso 1	6
Paso 2	7
Paso 3	8
Paso 4	9
Solución de problemas	10
Instrucciones de cuidado & uso	10
Información de garantía	10

Declaración de calidad

Preguntas o Comentarios?

Nos gustaría escuchar sobre su experiencia! Visitenos en:
www.whalenstyle.com

Información de seguridad importante

- *Por favor lea todas las instrucciones antes de ensamblar el mueble.*
- *Donde se pueda, y por su seguridad, se recomienda el ensamble por un adulto.*
- *Use solo ferretería suplida por el vendedor para ensamblar la unidad. El uso de ferretería no autorizada podría poner en riesgo la integridad estructural de la unidad.*
- *La ferretería se podría aflojar con el tiempo. Revisar periódicamente que las conexiones estén apretadas.*

Antes del ensamble

- *Retirar todas las partes y ferretería de la caja. Poner todo sobre una alfombra o en un are libre de rasguños, para evitar danos a las partes durante el ensamble.*
- *La caja de envió provee una superficie ideal de trabajo.*
- *Usar las listas de partes y ferretería para identificar y separar cada una de las piezas incluidas.*
- *Para evitar el desecho accidental de partes o ferretería pequeñas, no tire ningún paquete o contenidos del paquete hasta terminar el ensamble.*
- *El uso de herramientas eléctricas **NO** está recomendada, a menos que se especifique. Estas herramientas pueden dañar la ferretería o la madera.*
- *No apretar completamente los pernos/sujetadores hasta que las partes estén en su lugar. La falla de seguir estas instrucciones puede causar que los pernos/sujetadores se desalineen durante el ensamble.*

Cuidado & uso

- *Use una toalla suave y limpia para evitar daños y rayaduras.*
- *Uso de cera para pulir muebles no es necesario. Si desea usar cera cheque en un área que no sea visible para verificar su funcionamiento.*
- *Usar solventes de cualquier tipo puede dañar el terminado del mueble.*
- *Nunca use agua para limpiar la unidad, ya que le puede dañar el acabado.*
- *Líquidos derramados deben limpiarse inmediatamente, con una toalla suave evitando tallar.*
- *No poner el mueble en luz solar directa.*

Contenidos del paquete

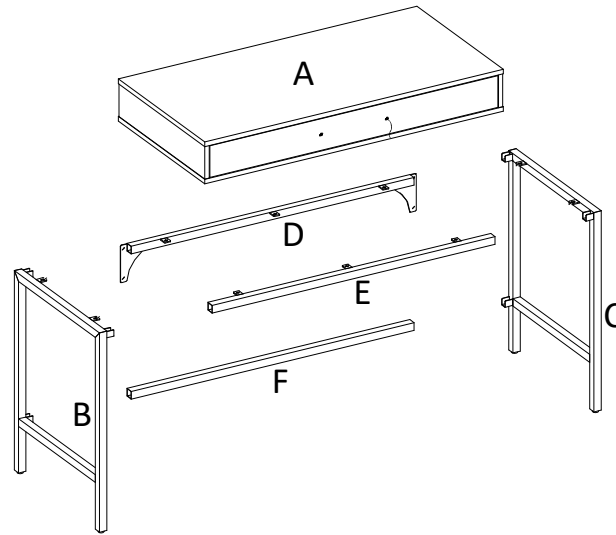

Componente	Descripción	Cantidad	Componente	Descripción	Cantidad
A	Tapa de escritorio	1	D	Soporte superior posterior	1
B	Marco izquierdo	1	E	Soporte frontal superior	1
C	Marco Derecho	1	F	Soporte inferior posterior	1

Información del producto

Dimensiones – **40" W x 20.75" D x 31.25" H (101.6cm W x 52.7cm Dx 79.3cm H)**



Capacidad de peso –Escritorio: 90,8 kg / 200 libras

Cajón: 9,1 kg / 20 libras.

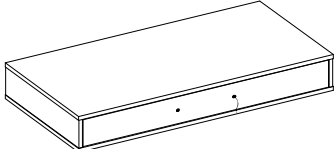
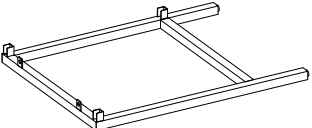
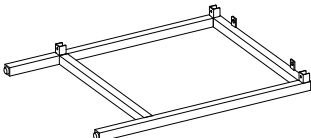
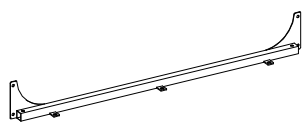
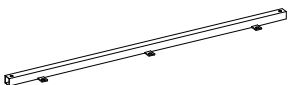
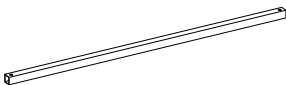
Componentes

<p>Componente A # de parte.00SMSSDSK-BLK-A 00SMSSDSK-NTL-A Cant. 1</p> 	<p>Componente B # de parte. 00SMSSDSK-BLK-B 00SMSSDSK-NTL-B Cant. 1</p> 	<p>Componente C # de parte.00SMSSDSK-BLK-C 00SMSSDSK-NTL-C Cant. 1</p> 
<p>Componente D # de parte.00SMSSDSK-BLK-D 00SMSSDSK-NTL-D Cant. 1</p> 	<p>Componente E # de parte.00SMSSDSK-BLK-E 00SMSSDSK-NTL-E Cant. 1</p> 	<p>Componente F # de parte.00SMSSDSK-BLK-F 00SMSSDSK-NTL-F Cant. 1</p> 

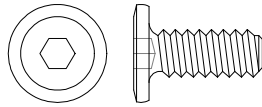
Material de ferretería

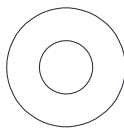
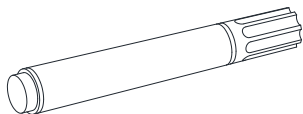
Perno de 1/4" x 15mm (H1) Cant. 20+1 extra	Arandela de presión (H2) Cant. 20+1 extra
	
Arandela plana (H3) Cant. 20+1 extra	Plumón (H4) Cant. 1
	

Herramientas

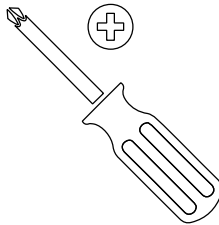
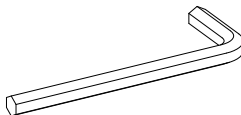
Desarmador estrella (No incluido)	Llave hexagonal (H5) (Incluidas) Cant. 1
	

Paso 1

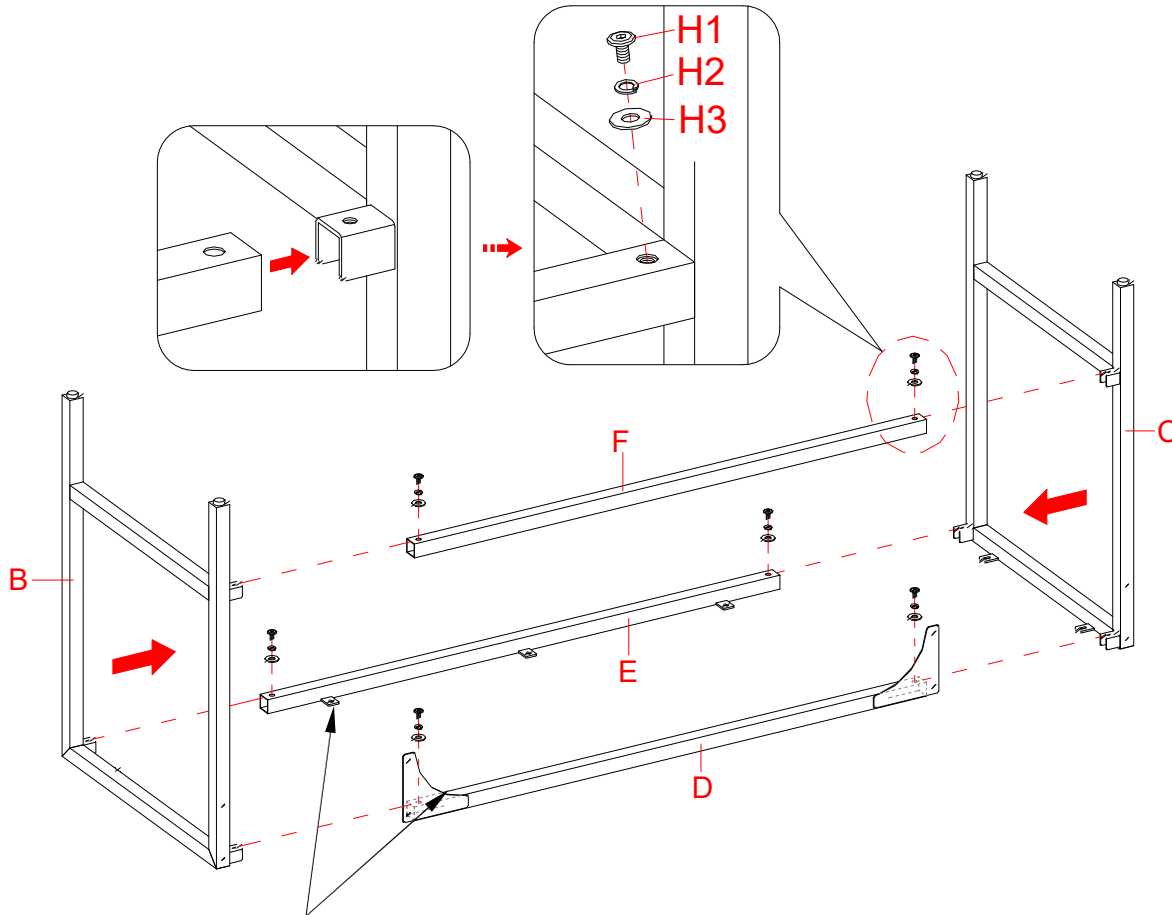
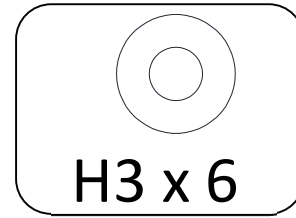
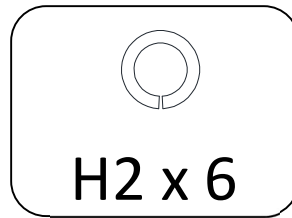
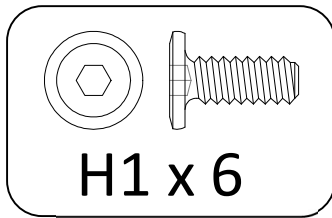

Las lengüetas de metal miran hacia adentro y están ubicadas hacia arriba cuando la unidad está en posición vertical.

- Desempacar la unidad y confirme que tiene todo el material de ferretería y las piezas necesarias.
- Oriente y ajuste tanto los soportes superiores (D y E) como el soporte inferior posterior (F) en los soportes en forma de U en el marco del lado izquierdo (B) con los orificios alineados. Fíjelos en su lugar con tres pernos de 15 mm (H1) y las arandelas (H2 y H3). Apriete los pernos con la llave hexagonal provista.
- Repetir el mismo procedimiento para adjuntar el Marco Derecho (C) al otro extremo.

Paso 2

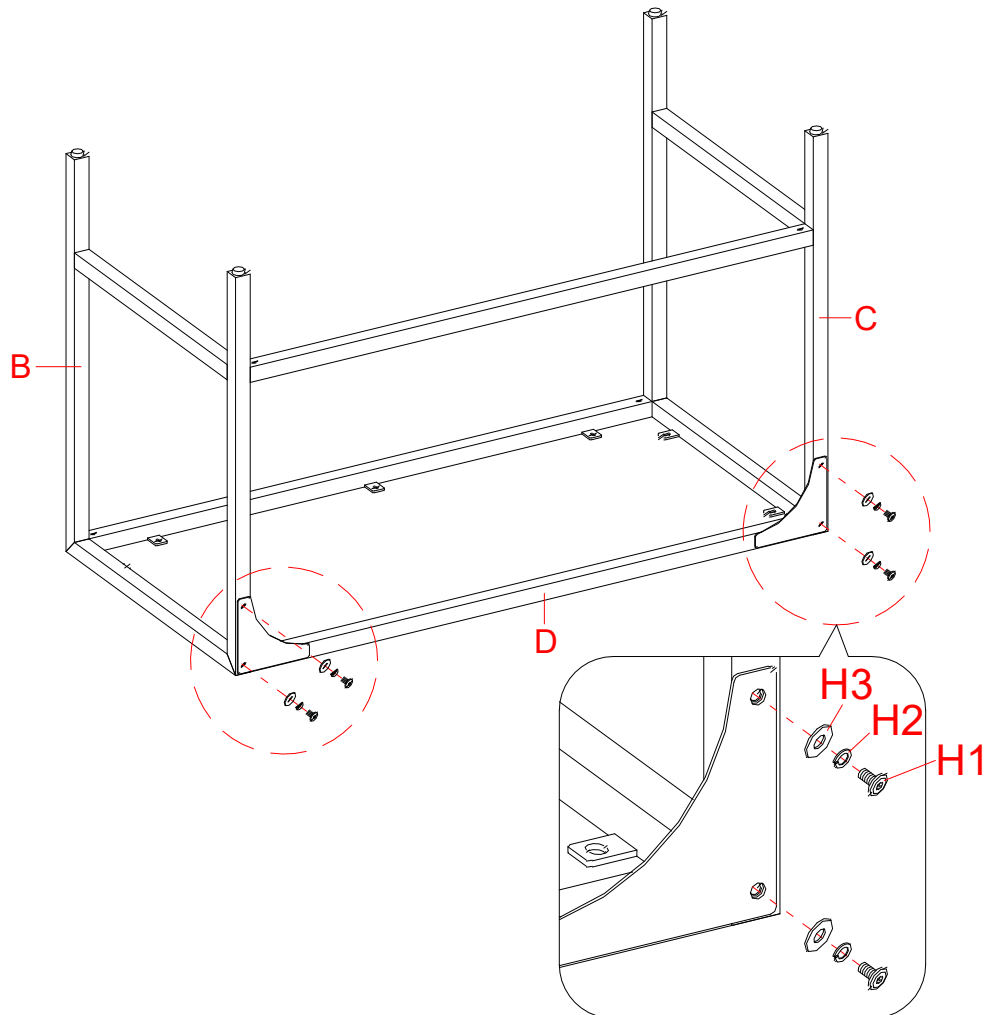
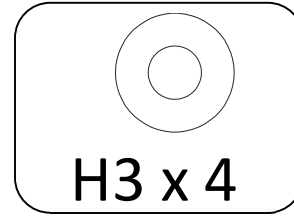
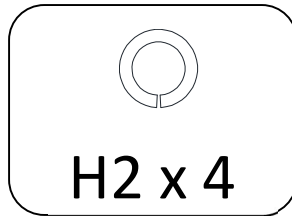
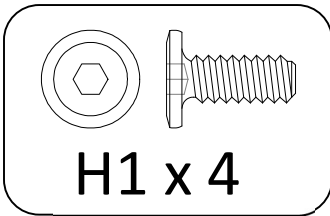

- a) Inserte cuatro pernos de 15 mm (H1) con las arandelas (H2 y H3) a través de las placas de metal en el soporte posterior superior (D) y atorníllelos firmemente en los casquillos roscados en ambos marcos laterales (B y C).

Paso 3

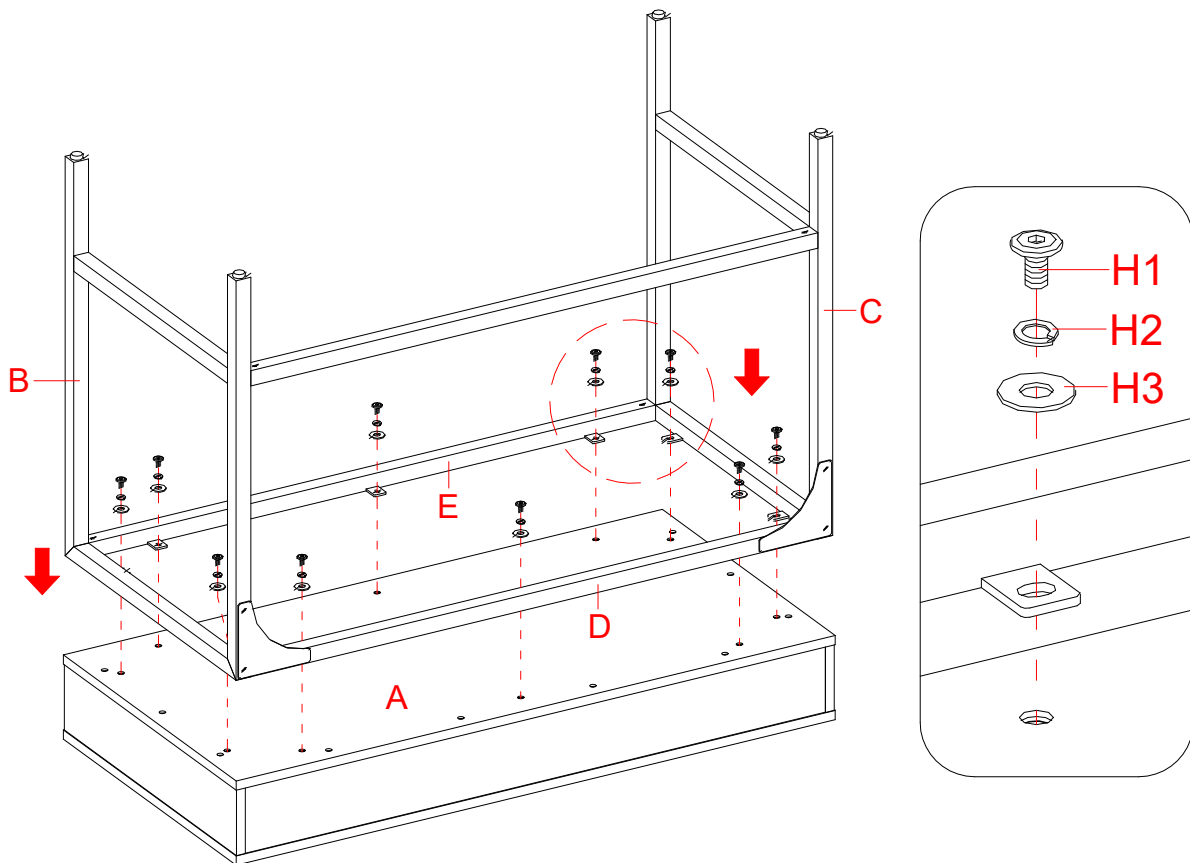
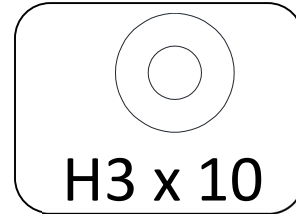
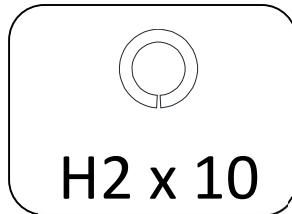
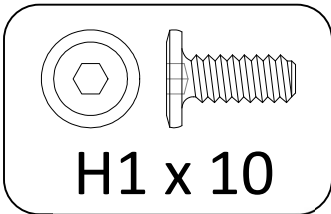

- Coloque el Escritorio (A) boca abajo sobre una superficie nivelada y protegida como se muestra.
- Alinee la base ensamblada con la parte superior del escritorio (A) correctamente e inserte diez pernos de 15 mm (H1) con arandelas (H2 y H3) a través de las lengüetas de metal y atorníllelos en los insertos roscados de la parte superior del escritorio (A).
- Ahora, volver y atornillar todas las pernos. Asegurar de que las partes estén fijas y de que no haya espacios entre las partes. Esto ayudará a mantener a la unidad cuadrada.

Paso 4

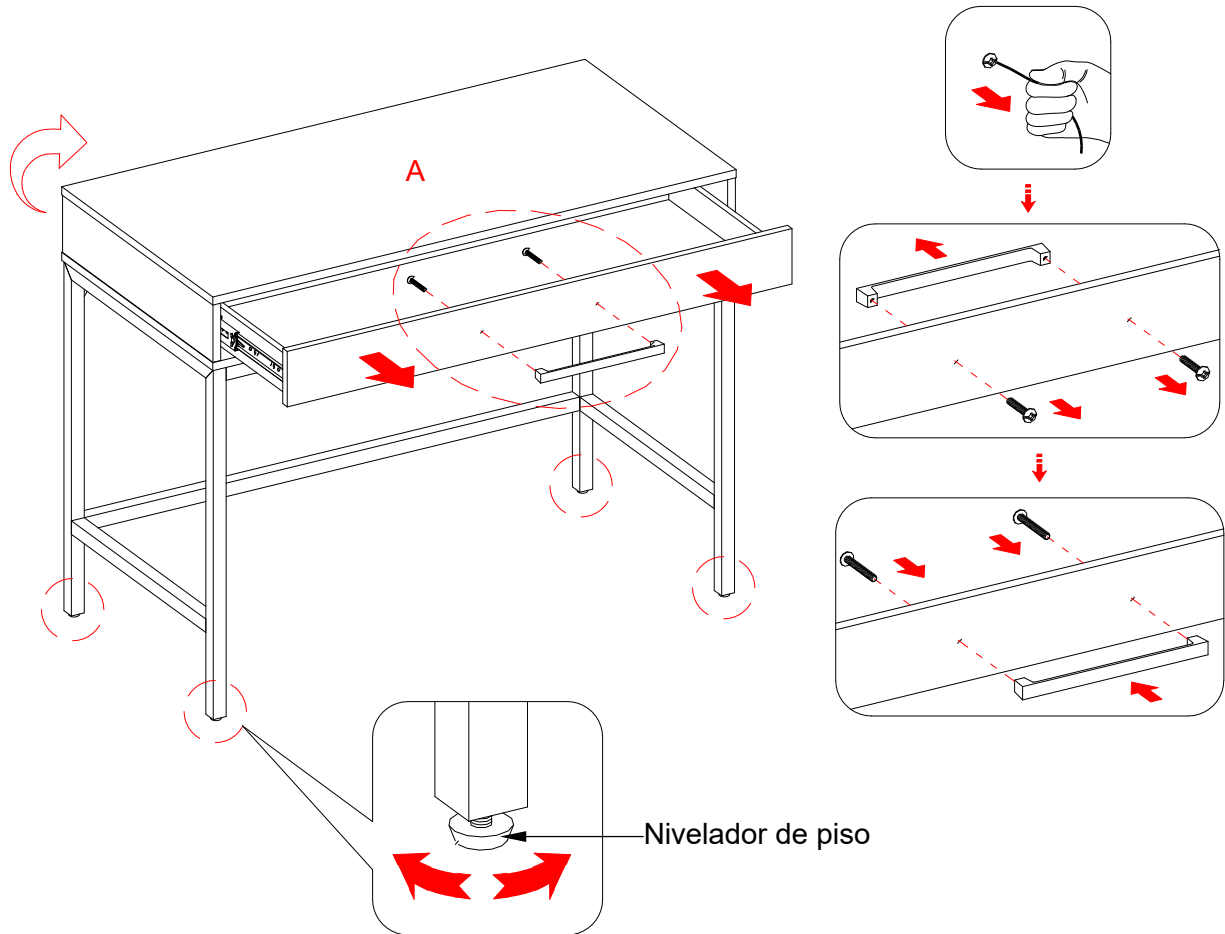

- Levante la unidad ensamblada en posición vertical y colóquela cerca de la ubicación final.
- El cajón viene con la manija preensamblada en el interior del cajón utilitario. Para quitar la manija, desatornille los pernos ubicados en el frente del cajón. Vuelva a instalar la manija en la parte delantera del cajón utilitario con los mismos pernos.
- Si fuera necesario, ajuste los niveladores de piso pre-adjuntados en la parte inferior de los marcos laterales (B y C) para corregir inclinación.

Solución de problemas

Problema	Posible Causa	Prevención / Solución
Inclinación / tambaleo	La superficie no está nivelada	Ajustar los niveladores de piso
Rayaduras / Cortes	Daños por el ensamble o envío	Use el plumón para cubrir

Instrucciones de cuidado & uso

Cuidado	No poner el mueble en luz solar directa, fuentes de calor o a la humedad.
	Use productos hechos específicamente para limpiar madera. Use un limpiador acondicionador para madera que no contenga ceras o silicones (probar el producto en un lugar invisible primero).
Uso	Revisar periódicamente para asegurar de que los componentes estén en el lugar correcto, libre de daño y conectados firmemente.
	Revisar los pernos periódicamente y apretarlos si es necesario.
	En caso de que su unidad sea manchada o dañada de otra forma durante el uso, le recomendamos hablar a un profesional para que le ayude.
	Líquidos derramados deben limpiarse inmediatamente, con una toalla suave evitando tallar.
	Nunca use agua para limpiar la unidad, ya que le puede dañar el acabado.
	Usar solventes de cualquier tipo puede dañar el acabado del mueble.

Información de garantía

Este producto tiene un (1) año de garantía en contra de defectos en el material y/o la obra de mano. Si usted tiene preguntas sobre la garantía o partes extras/de repuesto, por favor llame a nuestro número de llamada gratuita **1-866-942-5362** o mande un email a parts@whalenfurniture.com

NOTA: Por favor considere reciclar todo el material de empaque aplicable.

Whalen Furniture Manufacturing
1578 Air Wing Road, San Diego, CA 92154, USA
Hora Estándar del Pacífico: 8:30 a.m. - 4:30 p.m., de Lunes a Viernes
www.whalenstyle.com