

allen + roth®

welcoming • sophisticated • inspiring

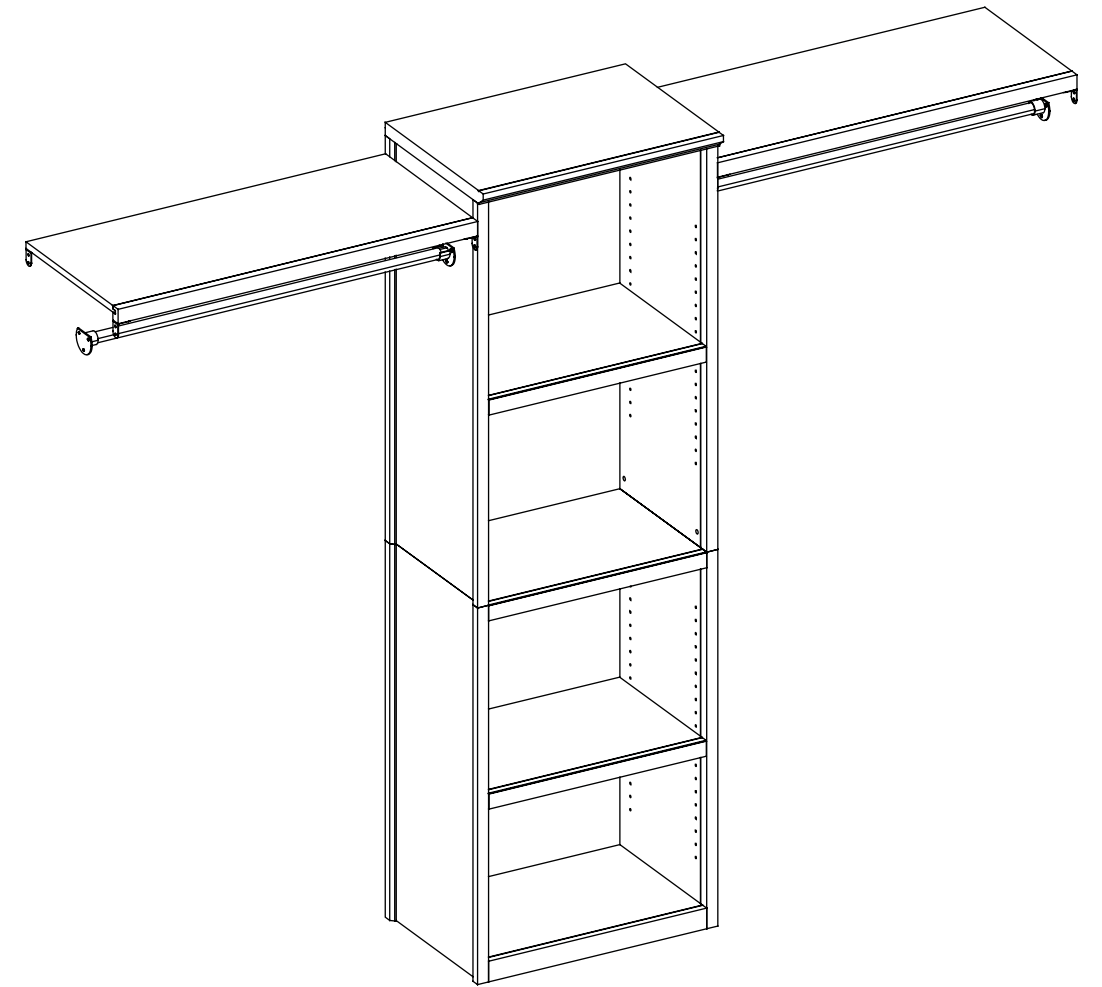

allen + roth® is a registered trademark of LF, LLC. All Rights Reserved.

ITEM #1029488, 1029489, 1029490

### SOLID CLOSET KIT

MODEL #WSLCSCCE, WSLCSCG, WSLCSCBW

**ATTACH YOUR RECEIPT HERE**

Serial Number \_\_\_\_\_ Purchase Date \_\_\_\_\_

Français p. 18

Español p. 35

**Questions, problems, missing parts?** Before returning to your retailer, call our customer service department at 1-866-439-9800, 8 a.m. - 8 p.m., EST, Monday - Friday.

## TABLE OF CONTENTS

Camlock System Operation.....	2
Package Contents.....	3
Hardware Contents.....	4
Safety Information.....	5
Preparation .....	6
Assembly Instructions.....	6
Care and Maintenance .....	13
Troubleshooting.....	13
Warranty.....	15
Replacement Parts List .....	15

## CAM LOCK SYSTEM OPERATION

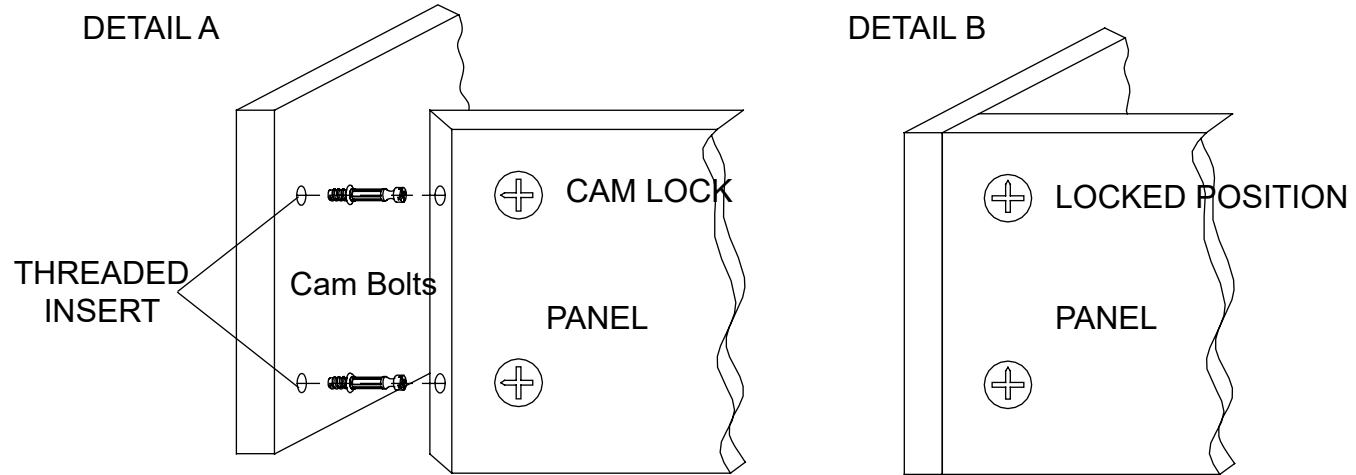

1. Screw cam bolts into the predrilled small holes on panel.
2. Insert cam lock into predrilled large hole on panel.
3. Make sure the arrow on the cam lock is pointed toward the cam bolts.
4. Connect both panels together, making sure cam bolts goes into predrilled hole on the end of panel with cam lock.
5. Once cam bolts is connected inside cam lock, take Phillips screwdriver and tighten cam lock clockwise.



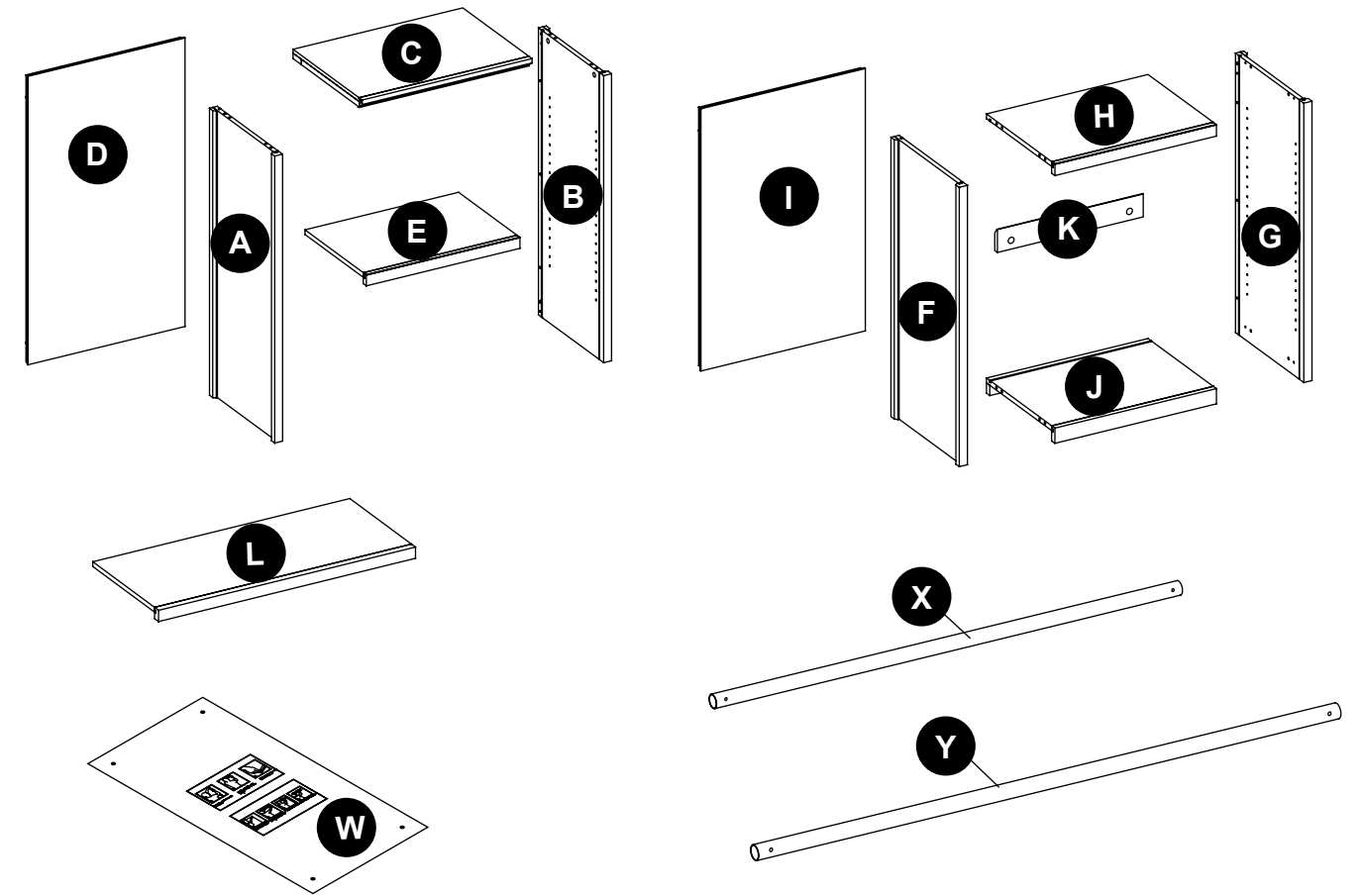





## PACKAGE CONTENTS

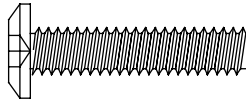
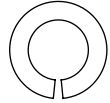
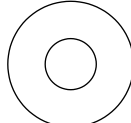

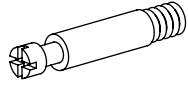

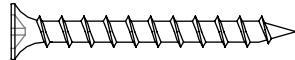
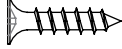
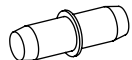
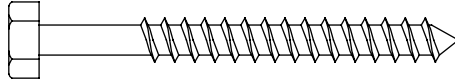
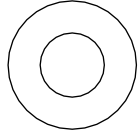
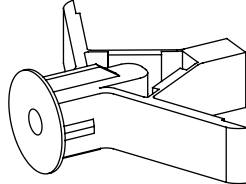
PART	DESCRIPTION	QUANTITY
A	Hutch Panel Left	1
B	Hutch Panel Right	1
C	Hutch Panel Top	1
D	Hutch Panel Back	1
E	Adjustable Shelf	2
F	Base Panel Left	1
G	Base Panel Right	1
H	Base Panel Top	1
I	Base Panel Back	1
J	Base Panel Bottom	1

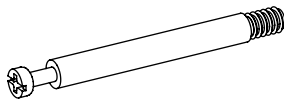
PART	DESCRIPTION	QUANTITY
K	Wall Hanging Cleat	2
L	Long Shelf	2
W	Installation Template	1
X	22 mm Metal Pole	2
Y	25 mm Metal Pole	2

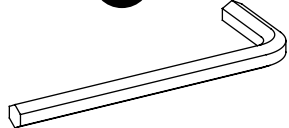
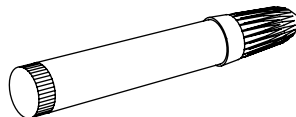
**HARDWARE CONTENTS** (shown not actual size)

<b>AA</b>	<b>BB</b>	<b>CC</b>	<b>DD</b>	<b>EE</b>
				
1/4 x 1-1/4 in. Bolt	Lock Washer	Flat Washer	Cam Lock	Small Cam Bolt
Qty. 12	Qty. 12	Qty. 12	Qty. 26	Qty. 22
<b>FF</b>	<b>GG</b>	<b>HH</b>	<b>II</b>	
				
Wood Dowel	M4 x 38 mm Wood Screw	M4 x 14 mm Wood Screw	Shelf Pin	
Qty. 26	Qty. 8	Qty. 24	Qty. 8	
<b>JJ</b>	<b>LL</b>	<b>NN</b>	<b>OO</b>	
				
M8 x 2-1/2 in. Lag Bolt	Large Flat Washer	Wall Anchor	L - Bracket	
Qty. 4	Qty. 4	Qty. 8	Qty. 8	
<b>PP</b>	<b>QQ</b>	<b>RR</b>	<b>SS</b>	
				
Large Cam Bolt	Barrel Nut	M4 Allen Wrench	Touch-up Pen	
Qty. 4	Qty. 4	Qty. 1	Qty. 1 (not included for white color)	

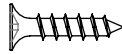
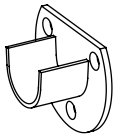
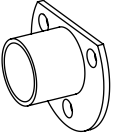
**HARDWARE CONTENTS** (for pole kit)

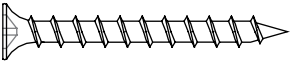
<b>MM</b>	<b>YY</b>	<b>ZZ</b>	<b>AB</b>	<b>KK</b>
				
M4 x 14 mm Zinc Wood Screw	Open Pole Holder	Closed Pole Holder	M4 x 15 mm Self-tapping Screw	M4 x 38 mm Zinc Screw
Qty. 6	Qty. 2	Qty. 2	Qty. 4	Qty. 6

**! SAFETY INFORMATION**

Please read and understand this entire manual before attempting to assemble, operate or install the product.

- Do not allow children to climb or play in or around this product.
- To avoid damage, assemble the product on a sturdy, level and protective surface.
- Two or more persons must work together to install the unit onto the wall.
- Make sure all bolts/screws are tightly fastened before the unit is used.
- Check bolts/screws periodically and tighten them if necessary.

**! WARNING**

- THIS UNIT IS INTENDED FOR USE ONLY WITH THE MAXIMUM WEIGHTS INDICATED. USE WITH PRODUCTS HEAVIER THAN THE MAXIMUM WEIGHTS INDICATED MAY RESULT IN INSTABILITY CAUSING POSSIBLE INJURY. DISTRIBUTE WEIGHT EVENLY.
- Shelf maximum load: 30 lbs
- Pole maximum load: 40 lbs.
- Pole maximum length: 60 in.

**CAUTION**

- Use this unit for its intended purpose only.
- Do not use shelves as step ladder.

## PREPARATION

Before beginning assembly of product, make sure all parts are present. Compare parts with package contents list and hardware contents list. If any part is missing or damaged, do not attempt to assemble the product.

**Estimated Assembly Time:** 120 minutes

Tools Required for Assembly (not included): Phillips Screwdriver, Power Drill, 3/16 in. Drill Bit, 3/8 in. Drill Bit, 1/2 in. Socket Wrench, Level, Stud Finder, Marking Pencil, Tape Measure, Step Ladder, and Hammer

## ASSEMBLY INSTRUCTIONS

### Base Assembly

1. Insert small cam bolts (EE) into base panel left (F), base panel right (G) and base panel top (H).

#### Hardware Used

**EE** Small Cam Bolt  x 12

2. Attach base panel back (I) and base panel top (H) to assembly using wood dowels (FF) and cam lock (DD).

**Note:** Make sure previously inserted small cam bolts (EE) are completely seated.

#### Hardware Used

**DD** Cam Lock  x 2

**FF** Wood Dowel  x 2

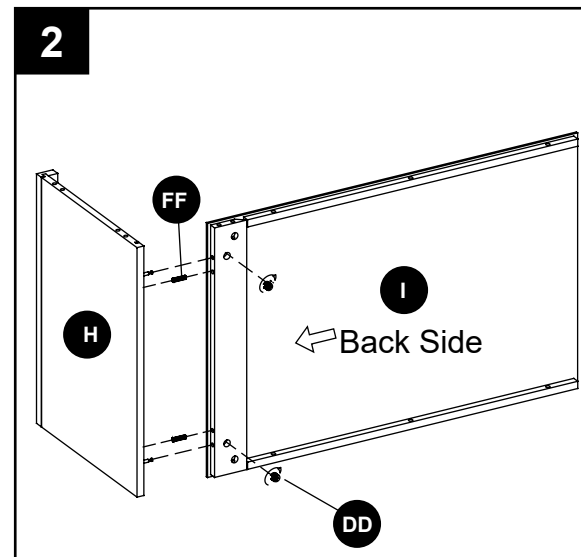
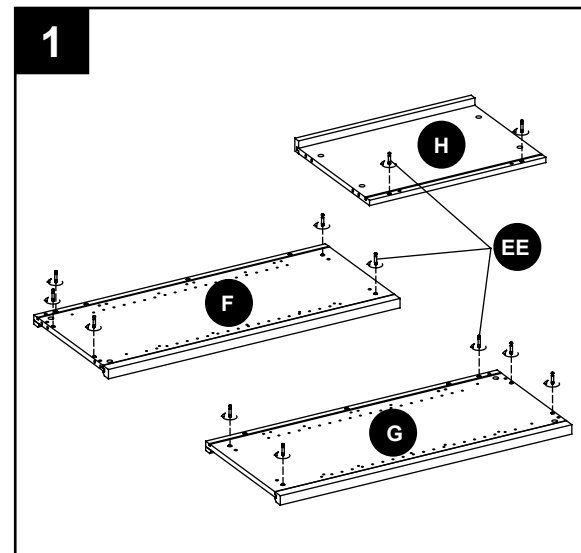

## ASSEMBLY INSTRUCTIONS

3. Attach base panel right (G) to assembly using wood dowels (FF) and cam locks (DD).

**Note:** Make sure previously inserted small cam bolts (EE) are completely seated.

#### Hardware Used

**DD** Cam Lock  x 2

**FF** Wood Dowel  x 3

4. From the back of the assembly, attach base panel right (G) to base panel back (I) using flat washers (CC), lock washers (BB) and bolts (AA). Tighten with allen wrench (RR).

#### Hardware Used

**AA** Bolt  x 3

**BB** Lock Washer  x 3

**CC** Flat Washer  x 3

**DD** Cam Lock  x 1

**RR** Allen Wrench  x 1

5. Fit base panel back (I) into slot of base panel bottom (J), then attach base panel bottom (J) to assembly using wood dowels (FF) and cam locks (DD).

**Note:** Make sure previously inserted small cam bolts (EE) are completely seated.

#### Hardware Used

**DD** Cam Lock  x 2

**FF** Wood Dowel  x 2

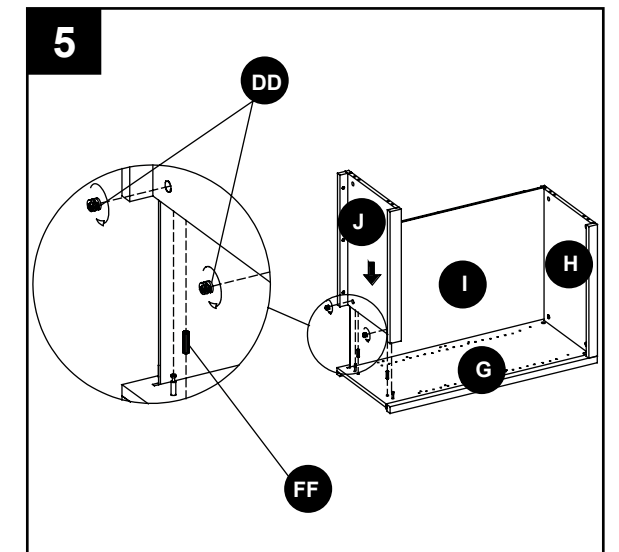
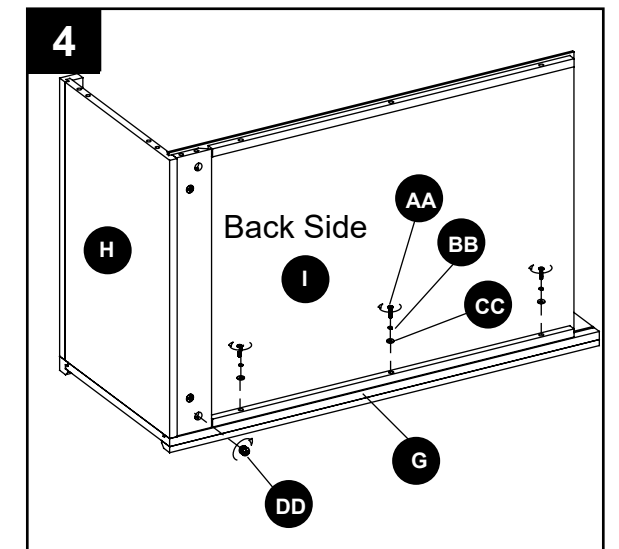
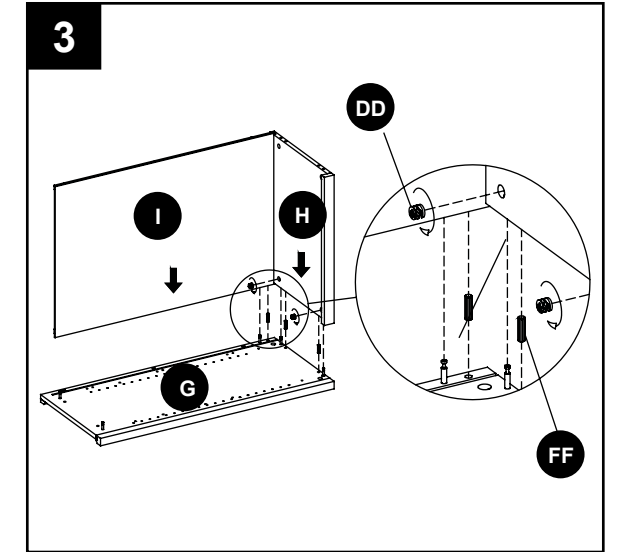

## ASSEMBLY INSTRUCTIONS

6. Attach base panel left (F) to assembly using wood dowels (FF) and cam locks (DD).



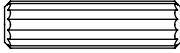

**Note:** Make sure previously inserted small cam bolts (EE) are completely seated.

### Hardware Used

<b>DD</b>	Cam Lock		x 4
<b>FF</b>	Wood Dowel		x 5

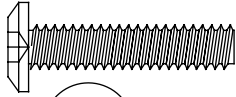
7. From the back of the assembly, attach base panel left (F) to base panel back (I) using flat washers (CC), lock washers (BB) and bolts (AA). Tighten with Allen wrench (RR).

### Hardware Used

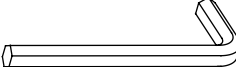
<b>AA</b>	Bolt		x 3
<b>BB</b>	Lock Washer		x 3
<b>CC</b>	Flat Washer		x 3
<b>DD</b>	Cam Lock		x 1
<b>RR</b>	Allen Wrench		x 1

### Hutch Assembly

8. Insert small cam bolts (EE) into hutch panel left (A), hutch panel right (B) and hutch panel top (C).

### Hardware Used

<b>EE</b>	Small Cam Bolt		x 10
-----------	----------------	---	------

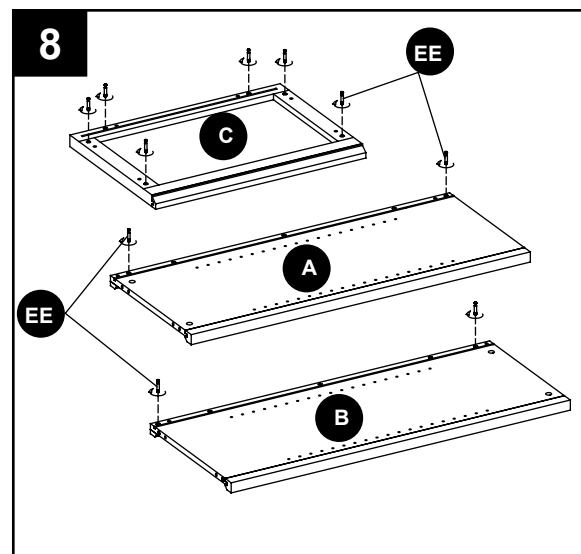
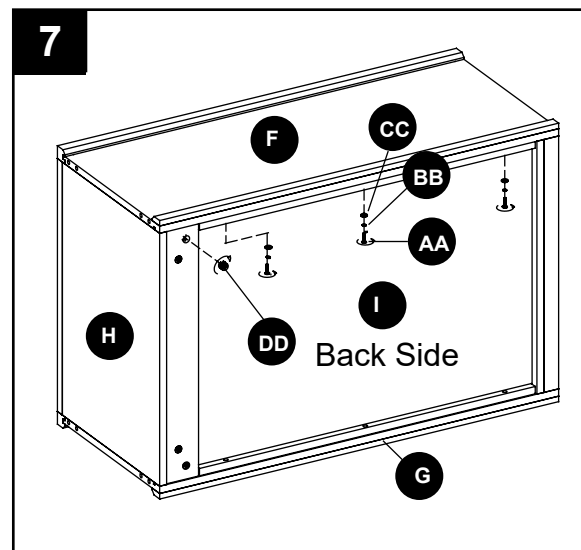
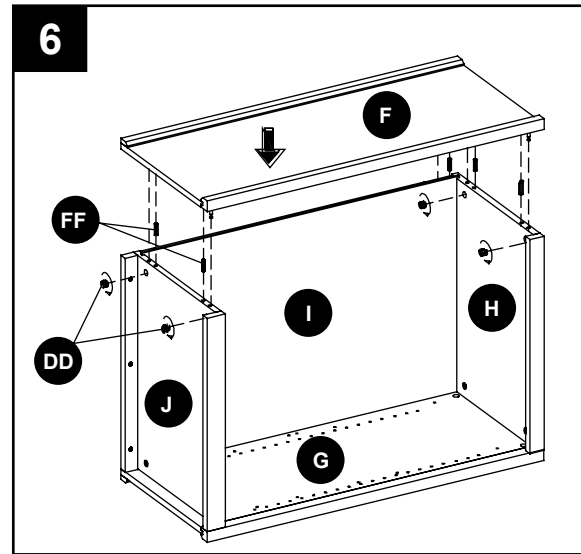





## ASSEMBLY INSTRUCTIONS

9. Attach hutch panel left (A) and hutch panel right (B) to hutch panel back (D), using wood dowels (FF) and cam locks (DD). From the back of the assembly, use flat washers (CC), lock washers (BB) and bolts (AA) to secure unit. Tighten with Allen wrench (RR). Then, secure assembly with cam locks (DD).

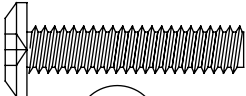
**Note:** Make sure previously inserted small cam bolts (EE) are completely seated.

### Hardware Used

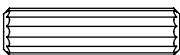
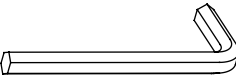
<b>AA</b>	Bolt		x 6
<b>BB</b>	Lock Washer		x 6
<b>CC</b>	Flat Washer		x 6
<b>DD</b>	Cam Lock		x 4
<b>FF</b>	Wood Dowel		x 4
<b>RR</b>	Allen Wrench		x 1

10. Insert wood dowels (FF) and cam locks (DD) into hutch assembly. Attach hutch panel top (C), tightening cam locks (DD) to secure assembly.

### Hardware Used

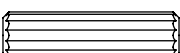
<b>DD</b>	Cam Lock		x 6
<b>FF</b>	Wood Dowel		x 6

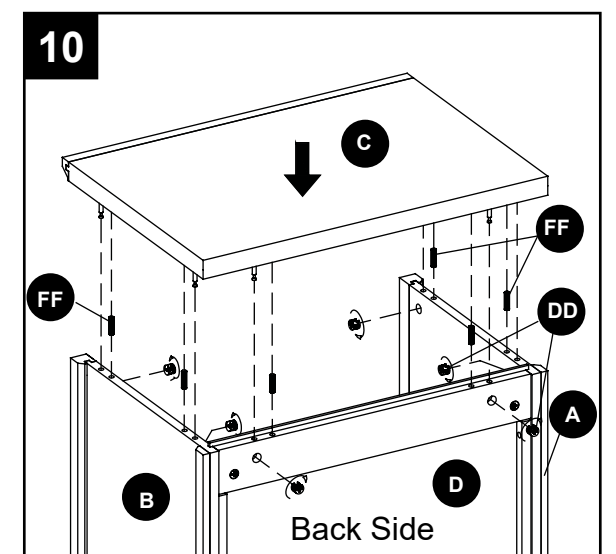
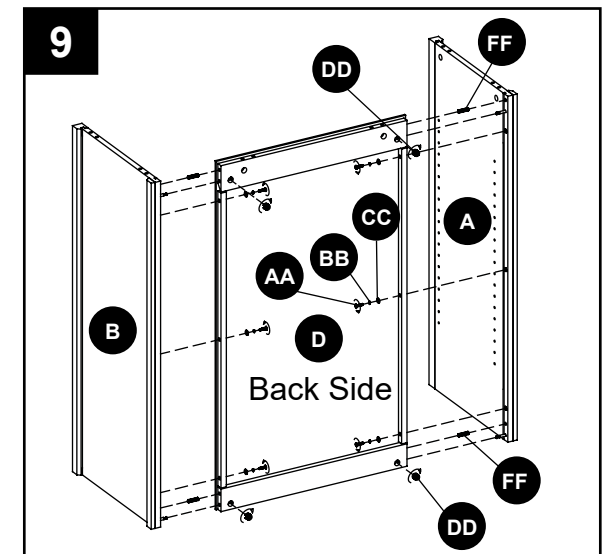



## ASSEMBLY INSTRUCTIONS

11. Carefully rest hutch assembly on its side. Insert barrel nuts (QQ) and large cam bolts (PP) into the bottom of the hutch assembly.

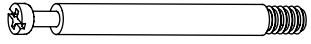
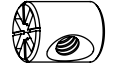

### Hardware Used

- PP** Large Cam Bolt  x 4
- QQ** Barrel Nut  x 4

12. Insert wood dowels (FF) and cam locks (DD) into the base panel left & right (F&G). Then, with the help of another person, attach the hutch assembly to the base assembly, tightening the cam locks (DD) to secure the unit.

**Note:** Make sure previously inserted large cam bolts (PP) are completely seated.

### Hardware Used

- DD** Cam Lock  x 4
- FF** Wood Dowel  x 4



### Wall Hanging Installation

13. Using a stud finder, locate the edges of the wood studs. Find the center line of each stud and draw a vertical reference line on the wall over each one. Position installation template (W) at desired location on wall.

**Note:** The bottom of the installation template (W) should be no less than 31-1/2 in. from the floor.

Mark mounting holes with a pencil (not included) and discard installation template (W). Drill 3/16 in. pilot holes at marked locations. Then, with the beveled edge facing up, attach the wall hanging cleats (K) with large flat washers (LL) and lag bolts (JJ).

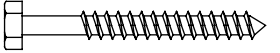
### Hardware Used

- JJ** M8 x 2-1/2 in. Lag Bolt  x 4
- LL** Large Flat Washer  x 4

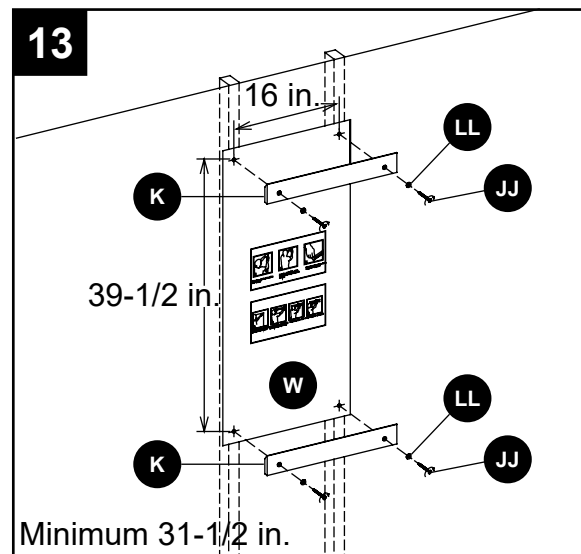
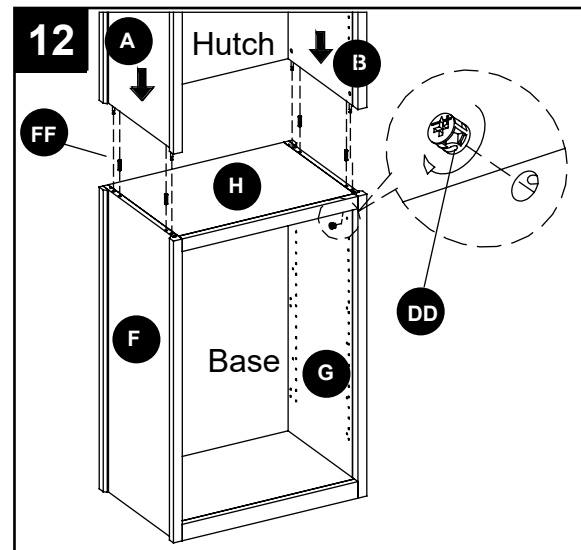
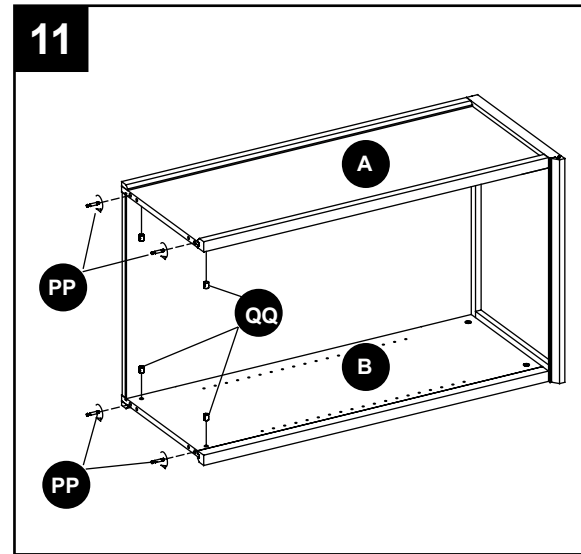

## ASSEMBLY INSTRUCTIONS



15. With the help from another person, carefully hang the unit onto wall hanging cleat (K).

### Long Shelf Installation

**Note:** If long shelf (L) needs cut to fit inside your closet space, cut only one side of the shelf and do not use a hacksaw. It is recommended you hire an insured remodeler for this type of installation.

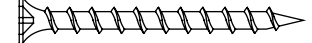
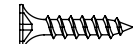
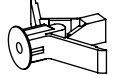

16. With a pencil, draw a level line at the desired mounting location for long shelf (L). Using L-brackets (OO) as a guide, mark the screw hole locations with a pencil. Drill 3/8 in. diameter pilot holes at least 2-1/2 in. deep at marked locations, then insert wall anchors (NN) into the holes until they are flush with the wall. Attach L-brackets (OO) to the wall using M4 x 38 mm screws (GG) and to the long shelf (L) using M4 x 14 mm wood screws (HH).

### Hardware Used

- GG** M4 x 38 mm Screw  x 8
- HH** M4 x 14 mm Wood Screw  x 8
- NN** Wall Anchor  x 8
- OO** L-Bracket  x 4

17. Attach long shelves (L) to hutch panel left (A) and hutch panel right (B) with L-brackets (OO), securing with M4 x 14 mm wood screws (HH).

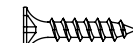
### Hardware Used

- HH** M4 x 14 mm Wood Screw  x 16
- OO** L-Bracket  x 4

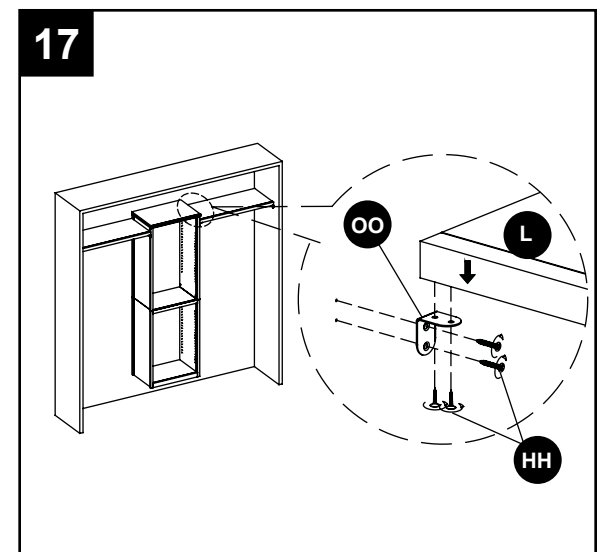
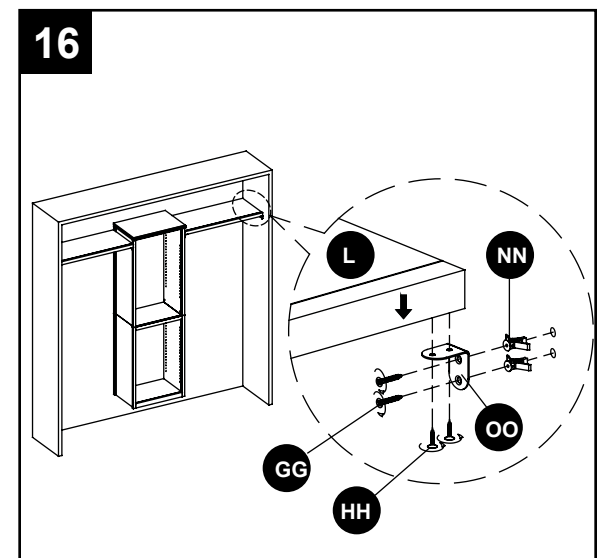
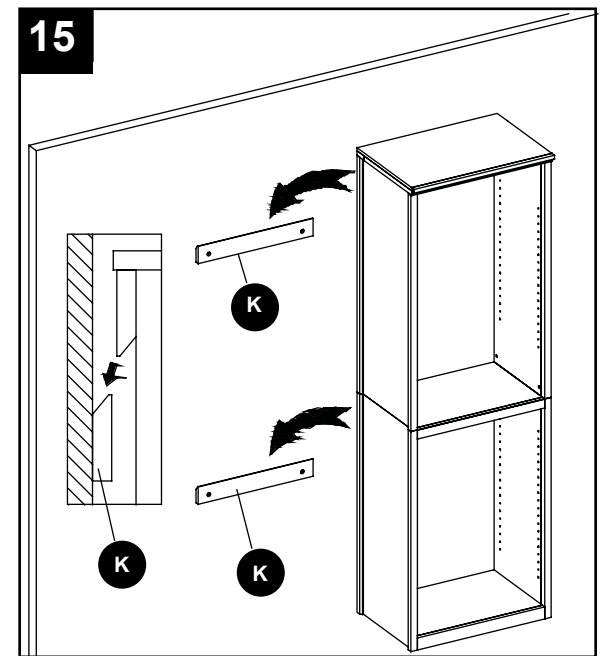

## ASSEMBLY INSTRUCTIONS

### Pole Installation

18. Insert 22 mm metal poles (X) into 25 mm metal poles (Y). Using closed pole holders (ZZ) as a guide, mark screw hole locations with a pencil. Drill 3/8 in. diameter pilot holes at least 2-1/2 in. deep at marked locations, then insert drywall anchors (not included) into the holes. Attach closed pole holders (ZZ) with M4 x 38 mm screws (KK). Insert 25 mm metal poles (Y) into closed pole holders (ZZ), securing with M4 x 15 mm self-tapping screws (AB).

**Note:** Drywall anchors are not required if installing into a stud.

#### Hardware Used

**KK** M4 x 38 mm Screw  x 6

**ZZ** Closed Pole Holder  x 2

**AB** M4 x 15 mm Self-tapping Screw  x 2

19. Attach open pole holders (YY) to hutch panel left (A) and hutch panel right (B), securing with M4 x 14 mm wood screws (MM). Insert 22 mm metal poles (X) into open pole holders (YY), securing with M4 x 15 mm self-tapping screws (AB).

#### Hardware Used

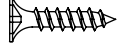
**MM** M4 x 14 mm Wood Screw  x 6

**YY** Open Pole Holder  x 2

**AB** M4 x 15 mm Self-tapping Screw  x 2

### Adjustable Shelf Installation

20. Insert shelf pins (II) where desired in cabinet, then rest adjustable shelf (E) on top.

**Note:** Ensure the shelf pins (II) are level.

#### Hardware Used

**II** Shelf pin  x 8

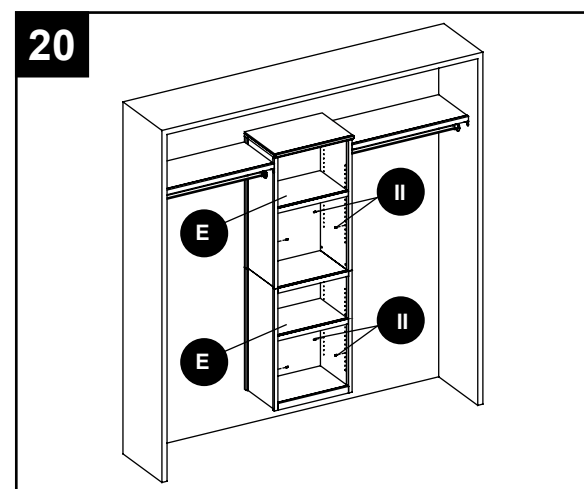
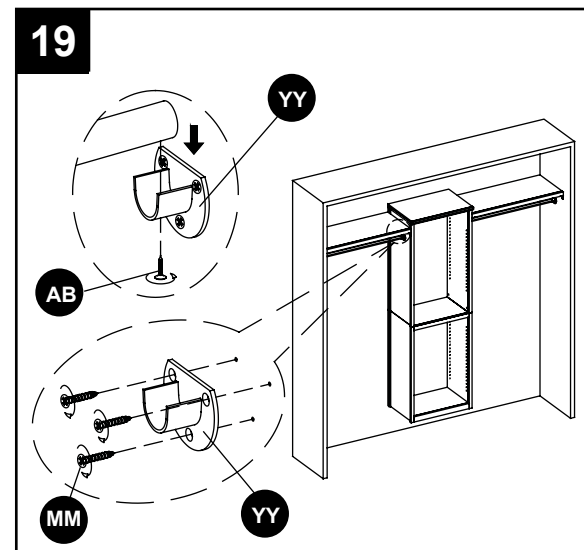
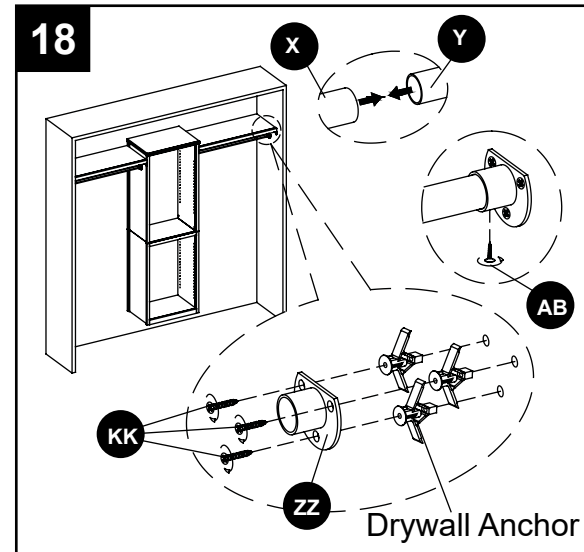

## CARE AND MAINTENANCE

- Periodically check to make certain all components are properly positioned, free from damage and firmly connected.
- Use a soft, clean cloth that will not scratch the surface when dusting.
- Never use water to clean the furniture as it may cause damage to the finish.
- Wipe clean using a damp cloth and a mild cleaner. Wipe dry with a clean cloth.
- In the event that the furniture is stained or otherwise damaged during use, it is recommended you call a professional to repair the furniture.
- Keep furniture away from direct sunlight as it may damage the finish.
- It is best to keep the furniture in a climate-controlled environment. Extreme temperature and humidity changes can cause fading, warping, shrinking and splitting of wood.
- Touch-up pen (SS) has been provided to repair any small nicks or scratches that may occur during assembly or shipping.

## TROUBLESHOOTING

PROBLEM	POSSIBLE CAUSE	CORRECTIVE ACTION
One end of long shelf (L) is floating.	The closet space is larger than 8 ft.	1. Buy corresponding shelf bracket and wall bracket (sold separately). 2. Replace long shelf (L) with a longer shelf of a similar finish and style.
Long shelf (L) can not be installed inside the closet.	The closet space is smaller than 8 ft.	1. Shorten one side of the long shelf (L). Hire an insured remodeler for installation. 2. Replace long shelf (L) with a shorter shelf of a similar finish and style.
The shelf is tilting.	The wall brackets and shelf brackets are not installed at the same level.	Use a quality level to ensure the brackets are leveled with each other.

## TROUBLESHOOTING

PROBLEM	POSSIBLE CAUSE	CORRECTIVE ACTION
One end of metal pole does not rest properly onto the open pole holder (YY).	The opening of open pole holder does not face upward vertically.	Use a quality level to ensure the flat edge of the open pole holder is level while installing.
The pole kit is tilting.	The open and closed pole holders are not installed at the same level.	Use a quality level to ensure the pole holders are level with each other.
Screw went through side panel.	Used M4 x 38 mm wood screws for attaching pole holder onto the side of cabinet.	Use M4 x 14 mm wood screws.
Closet tower tilted.	The wall hanging cleats are not level.	Reinstall the wall hanging cleats and ensure they are level.
Closet tower can not hang on the wall.	The mounting hole locations are not correct.	Reinstall wall hanging cleats; make sure the space between two wall hanging cleats is 39-1/2 in. and the bottom two mounting holes location is no less than 31-1/2 in. from the floor.

## WARRANTY

This product (exclusive of shelves) is warranted to the original purchaser. If there is a failure in this unit due to defects in materials or workmanship, the manufacturer will repair or replace this item at our discretion without charge. Warranty is void if product has been assembled incorrectly, misused, abused by overloading, altered in any way or damaged due to accident. This warranty is not transferable and does not cover chipping, flaking, scratches, rust, dents, or other damages to the surfaces of this product. Responsibility of the manufacturer is limited to repair or replacement of this product. The manufacturer is not responsible for consequential, incidental, or other damages or losses resulting from product failure.

This warranty is in lieu of all other expressed warranties. Some states do not allow the exclusion or limitation of incidental or consequential damages, so the above limitation may not apply to you. This warranty gives you specific legal rights and you may have other rights which vary from state to state.

## REPLACEMENT PARTS LIST

For replacement parts, call our customer service department at 1-866-439-9800, 8 a.m. - 8 p.m., EST, Monday - Friday.

PART	DESCRIPTION	PART #
A	Hutch Panel Left	*WSLCSCE/G/BW-01-HPL
B	Hutch Panel Right	*WSLCSCE/G/BW-02-HPR
C	Hutch Panel Top	*WSLCSCE/G/BW-03-HPT
D	Hutch Panel Back	*WSLCSCE/G/BW-04-HPB
E	Adjustable Shelf	*WSLCSCE/G/BW-05-AS
F	Base Panel Left	*WSLCSCE/G/BW-06-BPL
G	Base Panel Right	*WSLCSCE/G/BW-07-BPR
H	Base Panel Top	*WSLCSCE/G/BW-08-BPT
I	Base Panel Back	*WSLCSCE/G/BW-09-BPB
J	Base Panel Bottom	*WSLCSCE/G/BW-10-BPB
K	Wall Hanging Cleat	*WSLCSCE/G/BW-11-WHC
L	Long Shelf	*WSLCSCE/G/BW-12-LS
W	Installation Template	*WSLCSCE/G/BW-13-IT
X	22 mm Metal Pole	*WSLCSCE/G/BW-14-22MP
Y	25 mm Metal Pole	*WSLCSCE/G/BW-15-25MP



PART	DESCRIPTION	PART #
AA	Bolt	*WSLCSCE/G/BW-16-1 1/4B
BB	Lock Washer	*WSLCSCE/G/BW-17-LW
CC	Flat Washer	*WSLCSCE/G/BW-18-FW
DD	Cam Lock	*WSLCSCE/G/BW-19-CL
EE	Small Cam Bolt	*WSLCSCE/G/BW-20-SCB
FF	Wood Dowel	*WSLCSCE/G/BW-21-WD
GG	M4 x 38 mm Wood Screw	*WSLCSCE/G/BW-22-38WS
HH	M4 x 14 mm Wood Screw	*WSLCSCE/G/BW-23-14WS
II	Shelf Pin	*WSLCSCE/G/BW-24-SP
JJ	M8 x 2-1/2 in. Lag Bolt	*WSLCSCE/G/BW-25-2 1/2LB
LL	Large Flat Washer	*WSLCSCE/G/BW-26-LFW
NN	Wall Anchor	*WSLCSCE/G/BW-27-WA
OO	L - Bracket	*WSLCSCE/G/BW-28-LB
PP	Large Cam Bolt	*WSLCSCE/G/BW-29-LCB
QQ	Barrel Nut	*WSLCSCE/G/BW-30-BN
RR	M4 Allen Wrench	*WSLCSCE/G/BW-31-M4AW
SS	Touch-up Pen	*WSLCSCE/G/BW-32-TUP
MM	M4 x 14 mm Zinc Wood Screw	*WSLCSCE/G/BW-33-14ZWS
YY	Open Pole Holder	*WSLCSCE/G/BW-34-OPH
ZZ	Closed Pole Holder	*WSLCSCE/G/BW-35-CPH
AB	M4 x 15 mm Self-tapping Screw	*WSLCSCE/G/BW-36-15SS
KK	M4 x 38 mm Zinc Screw	*WSLCSCE/G/BW-37-38ZS
	Complete Hardware	*WSLCSCE/G/BW-38-CH
	Complete Hardware for Pole Kit	*WSLCSCE/G/BW-39-CHFPK

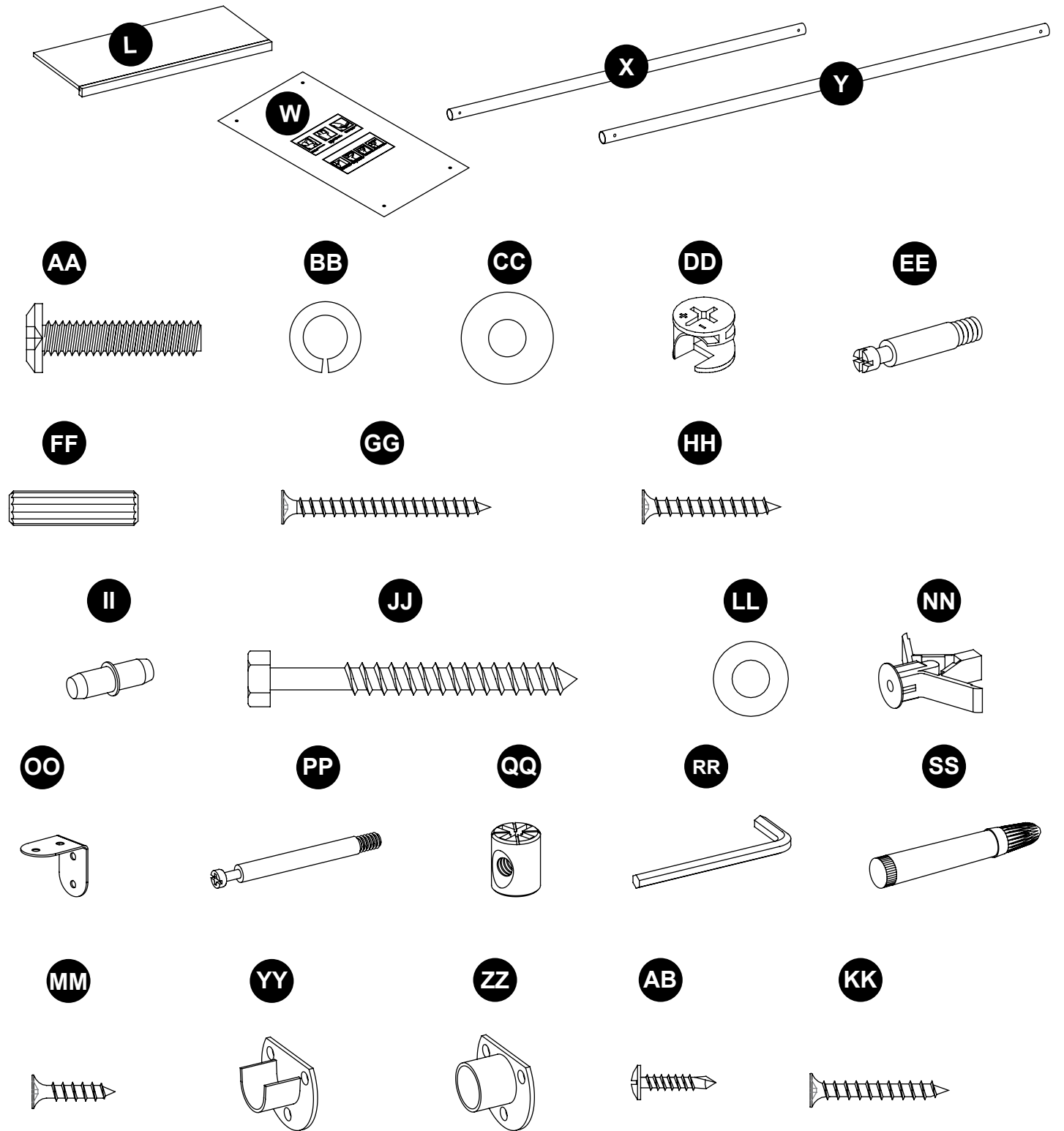
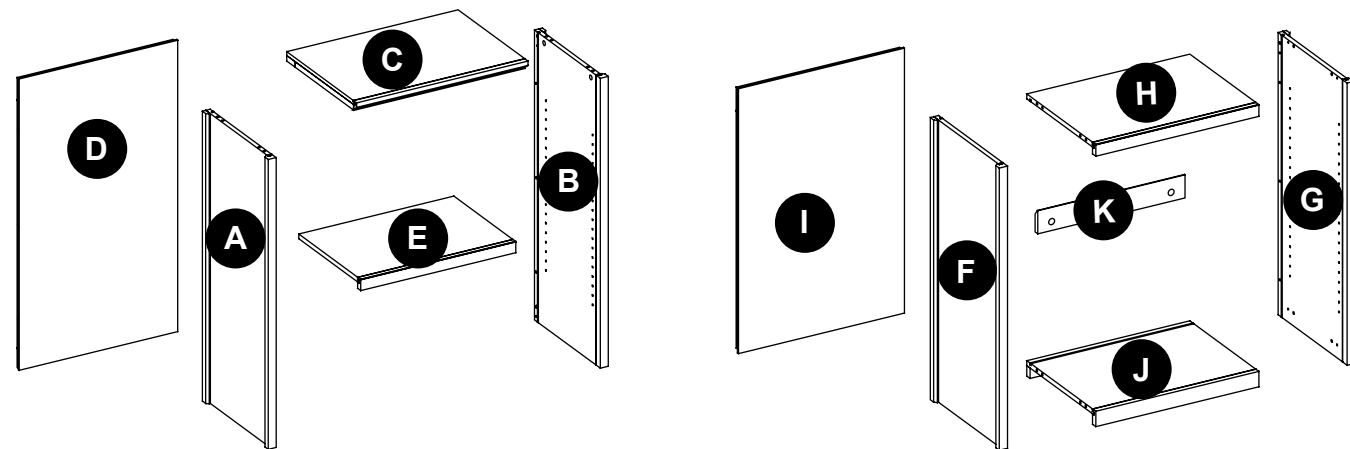

Printed in Vietnam

Date: 2018-03-07 Rev. 0001-A  
Factory # MEIFUR

allen + roth® is a registered trademark  
of LF, LLC. All Rights Reserved.

allen + roth®

welcoming • sophisticated • inspiring

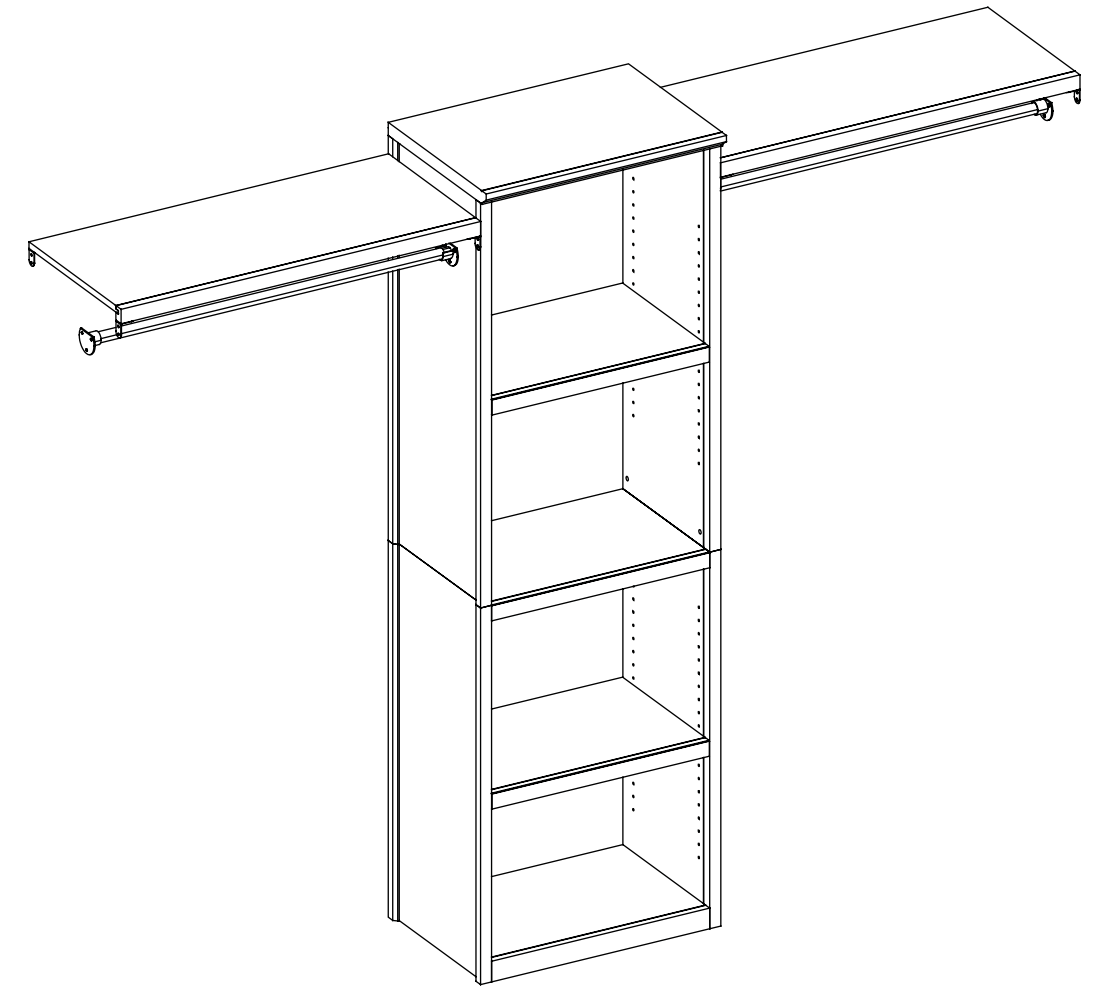

allen + roth® est une marque de commerce déposée de LF, LLC. Tous droits réservés.

ARTICLE #1029488, 1029489, 1029490

## ENSEMBLE PLEIN POUR LE PLACARD

MODÈLE #WSLCSCCE, WSLCSCG, WSLCSCBW

JOIGNEZ VOTRE REÇU ICI

Numéro de série \_\_\_\_\_ Date d'achat \_\_\_\_\_

**Des questions, des problèmes, des pièces manquantes?** Avant de retourner l'article au détaillant, appelez notre service à la clientèle au 1 866 439-9800, entre 8 h et 20 h (HNE), du lundi au vendredi.

## TABLE DES MATIÈRES

Fonctionnement du système Camloc .....	19
Contenu de l'emballage.....	20
Quincaillerie incluse.....	21
Consignes de sécurité.....	22
Préparation .....	23
Instructions pour l'assemblage.....	23
Entretien .....	30
Dépannage.....	30
Garantie.....	32
Liste des pièces de rechange.....	32

## FONCTIONNEMENT DU SYSTÈME CAMLOC

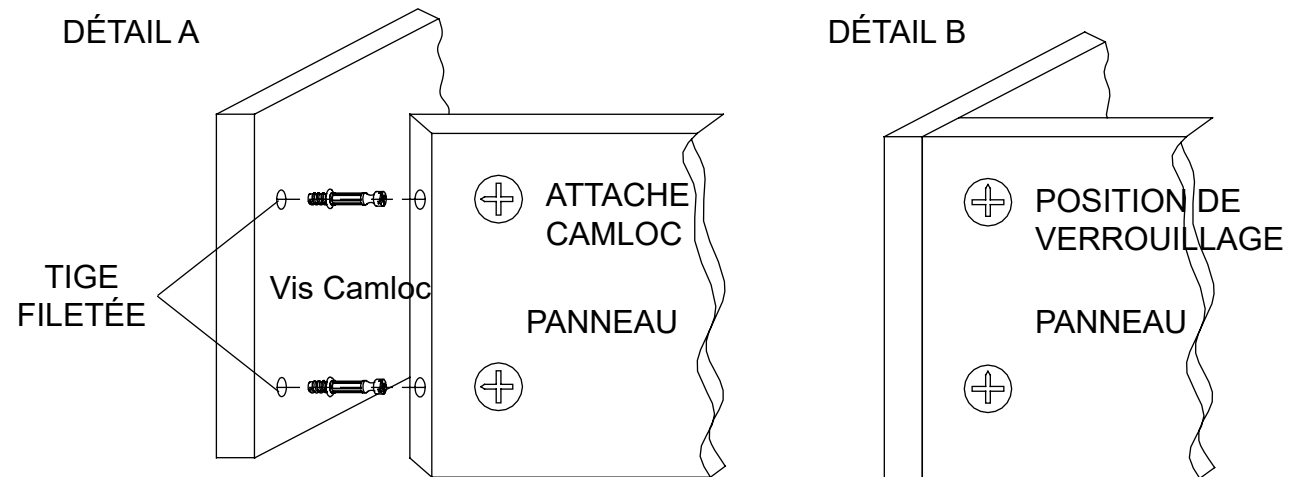

1. Vissez les vis Camloc dans les petits trous déjà percés sur le panneau.
2. Insérez les attaches Camloc dans les grands trous déjà percés sur le panneau.
3. Assurez-vous que les flèches sur les attaches Camloc pointent vers les vis Camloc.
4. Reliez les deux panneaux ensemble, en vous assurant que les vis Camloc s'insèrent correctement dans les trous déjà percés situés à l'extrémité du panneau sur lequel sont installées les attaches Camloc.
5. Une fois les vis Camloc insérées dans les attaches Camloc, serrez les attaches Camloc dans le sens des aiguilles d'une montre à l'aide d'un tournevis cruciforme.

## CONTENU DE L'EMBALLAGE

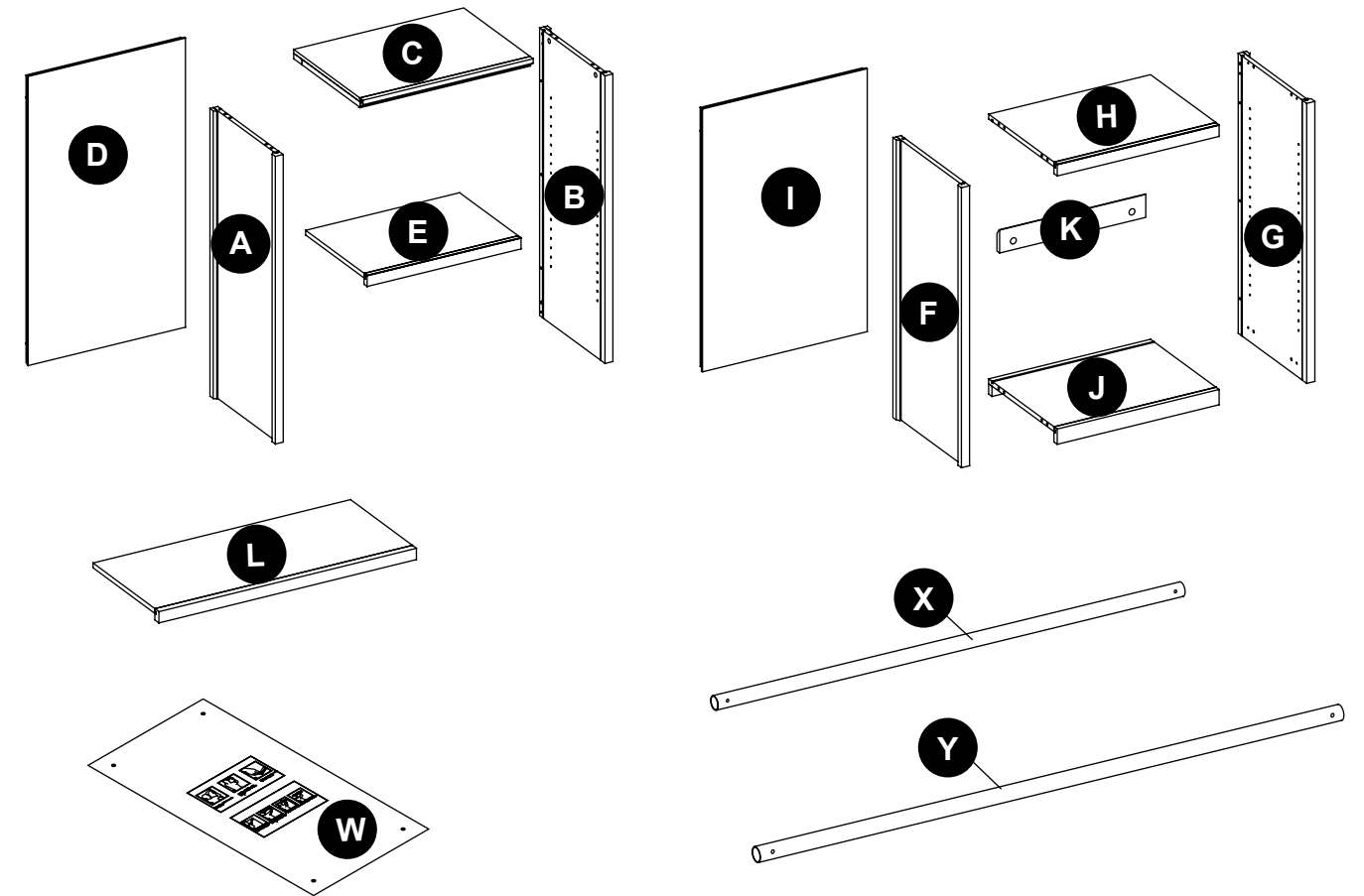

PIÈCE	DESCRIPTION	QUANTITÉ
A	Panneau gauche de l'étagère	1
B	Panneau droit de l'étagère	1
C	Panneau supérieur de l'étagère	1
D	Panneau arrière de l'étagère	1
E	Tablette réglable	2
F	Panneau gauche de la base	1
G	Panneau droit de la base	1
H	Panneau supérieur de la base	1
I	Panneau arrière de la base	1

PIÈCE	DESCRIPTION	QUANTITÉ
J	Panneau inférieur de la base	1
K	Traverse de fixation au mur	2
L	Tablette longue	2
W	Gabarit pour l'installation	1
X	Tringle métallique de 22 mm	2
Y	Tringle métallique de 25 mm	2

## QUINCAILLERIE INCLUSE (non illustrée à la grandeur réelle)

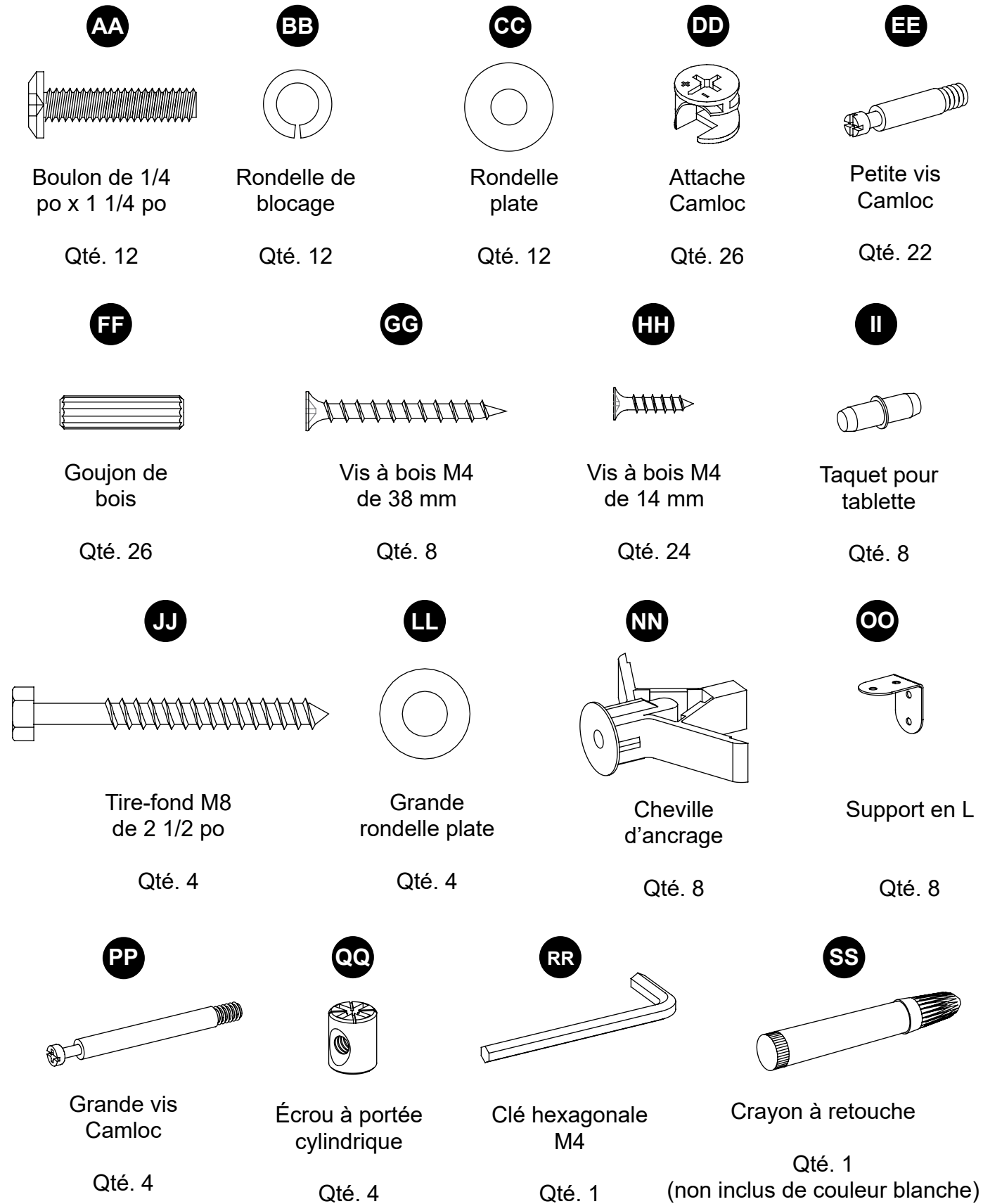

## HARDWARE CONTENTS (for pole kit)

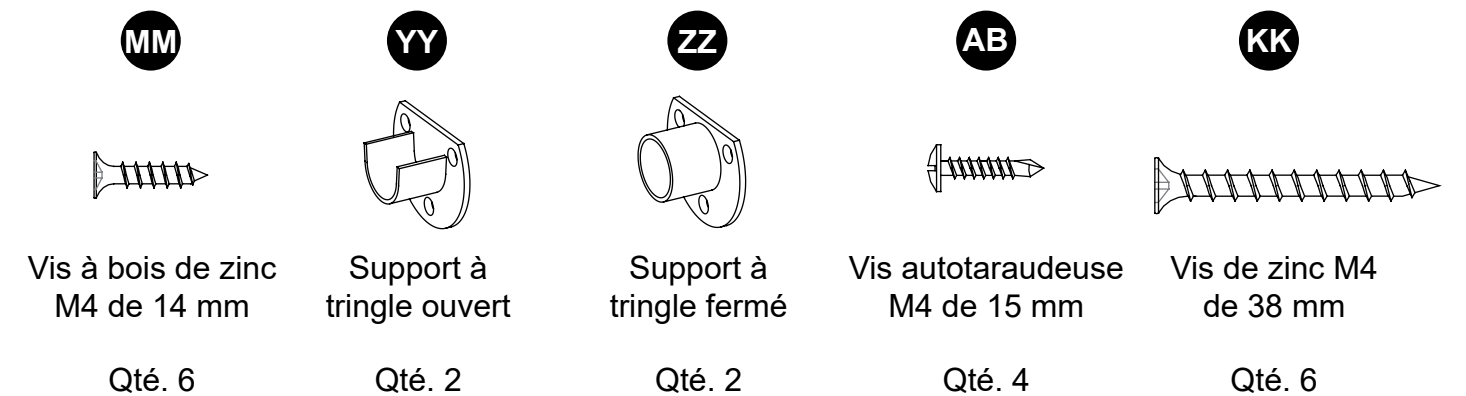

### ! CONSIGNES DE SÉCURITÉ

Assurez-vous de lire et de comprendre l'intégralité du présent manuel avant de tenter d'assembler, d'utiliser ou d'installer le produit.

- Ne laissez pas les enfants grimper ou jouer sur l'article ni autour de celui-ci.
- Assemblez l'article sur une surface solide, plane et protectrice, pour éviter de l'endommager.
- Deux personnes ou plus doivent travailler de concert pour installer cet article au mur.
- Assurez-vous que tous les boulons et toutes les vis sont bien serrés avant d'utiliser l'article.
- Vérifiez les boulons et les vis régulièrement et serrez-les au besoin.

### ! AVERTISSEMENT

- CET ARTICLE NE PEUT SUPPORTER QUE LA CHARGE MAXIMALE INDIQUÉE. L'UTILISATION DE CET ARTICLE AVEC DES PRODUITS DONT LE POIDS DÉPASSE LA CHARGE MAXIMALE INDIQUÉE PEUT ENTRAÎNER DE L'INSTABILITÉ ET CAUSER DES BLESSURES. RÉPARTISSEZ LA CHARGE DE FAÇON UNIFORME.
- Charge maximale de la tablette: 13,61 kg
- Charge maximale de la tringle: 18,14 kg
- Longueur maximale de la tringle: 152,40 cm

### ATTENTION

- Utilisez cet article uniquement pour l'usage auquel il est destiné.
- N'utilisez pas les tablettes comme s'il s'agissait d'une échelle.

## PRÉPARATION

Avant de commencer l'assemblage de l'article, assurez-vous d'avoir toutes les pièces. Comparez le contenu de l'emballage avec la liste des pièces et celle de la quincaillerie incluse. S'il y a des pièces manquantes ou endommagées, ne tentez pas d'assembler l'article.

**Temps d'assemblage approximatif:** 120 minutes

Outils nécessaires pour l'assemblage (non inclus) : tournevis cruciforme, perceuse électrique, foret de 3/16 po, foret de 3/8 po, clé à douille de 1/2 po, niveau, détecteur de montants, crayon, ruban à mesurer, escabeau et marteau.

## INSTRUCTIONS POUR L'ASSEMBLAGE

### Assemblage de la base

1. Insérez des petite vis Camloc (EE) dans le panneau gauche de la base (F), dans le panneau droit de la base (G) et dans le panneau supérieur de la base (H).

#### Quincaillerie utilisée

**EE** Petite vis Camloc  x 12

2. Fixez le panneau arrière de la base (I) et le panneau supérieur de la base (H) à l'ensemble à l'aide de goujons de bois (FF) et de attaches Camloc (DD).

**Remarque:** Assurez-vous que les petite vis Camloc (EE) que vous avez déjà installées sont entièrement enfoncées.

#### Quincaillerie utilisée

**DD** Attache Camloc  x 2

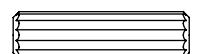
**FF** Goujon de bois  x 2

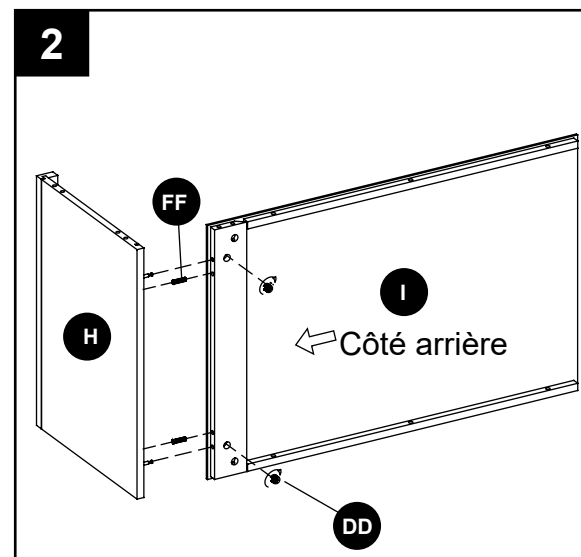
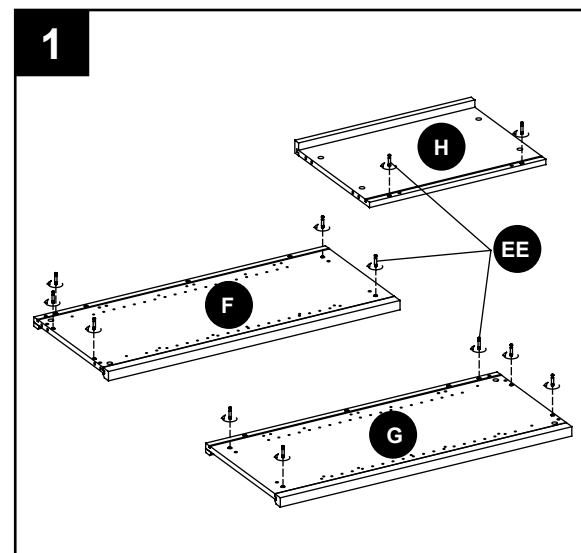

## INSTRUCTIONS POUR L'ASSEMBLAGE

3. Fixez le panneau droit de la base (G) à l'ensemble à l'aide de goujons de bois (FF) et de attaches Camloc (DD).

**Remarque:** Assurez-vous que les petite vis Camloc (EE) que vous avez déjà installées sont entièrement enfoncées.

#### Quincaillerie utilisée

**DD** Attache Camloc  x 2

**FF** Goujon de bois  x 3

4. À partir de l'arrière de l'ensemble, fixez le panneau gauche de la base (G) au panneau arrière de la base (I) à l'aide de rondelles plates (CC), de rondelles de blocage (BB) et de boulons (AA). Serrez les boulons à l'aide de la clé hexagonale (RR).

#### Quincaillerie utilisée

**AA** Boulon  x 3

**BB** Rondelle de blocage  x 3

**CC** Rondelle plate  x 3

**DD** Attache Camloc  x 1

**RR** Clé hexagonale  x 1

5. Insérez le panneau arrière de la base (I) dans la fente du panneau inférieur de la base (J), puis fixez le panneau inférieur à l'ensemble à l'aide de goujons de bois (FF) et de attaches Camloc (DD).

**Remarque:** Assurez-vous que les petite vis Camloc (EE) que vous avez déjà installées sont entièrement enfoncées.

#### Quincaillerie utilisée

**DD** Attache Camloc  x 2

**FF** Goujon de bois  x 2

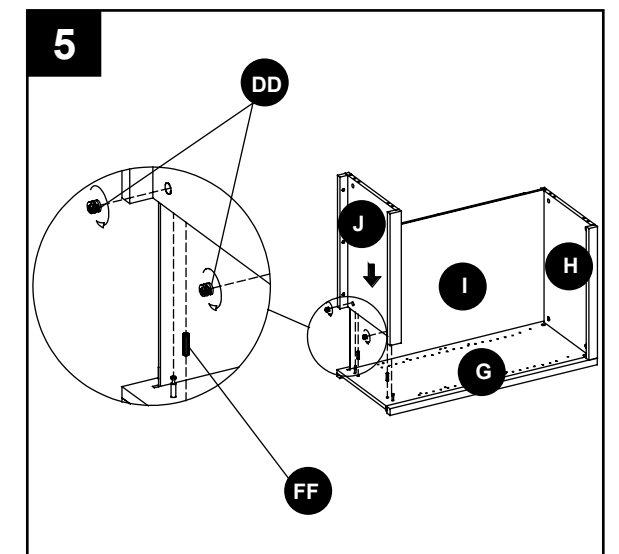
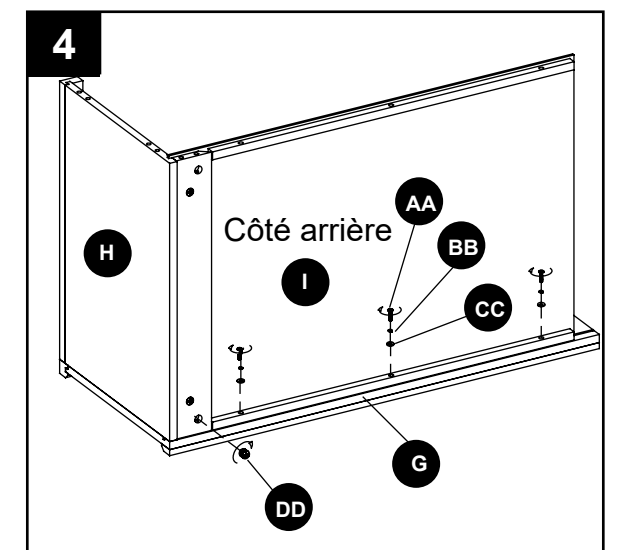
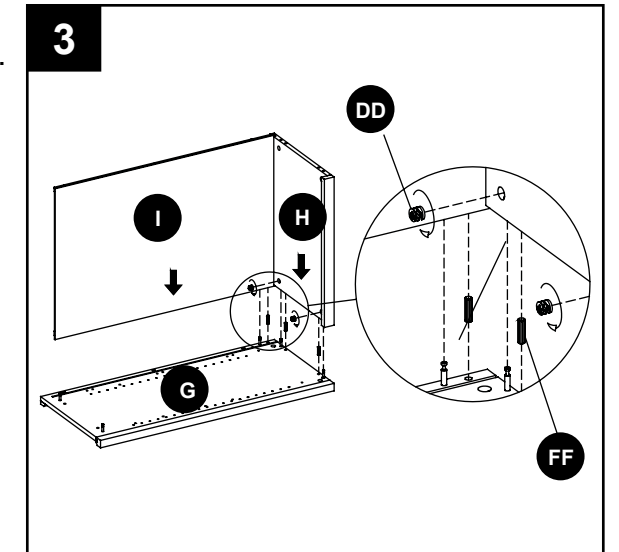





## INSTRUCTIONS POUR L'ASSEMBLAGE

6. Fixez le panneau gauche de la base (F) à l'ensemble à l'aide de goujons de bois (FF) et de attaches Camloc (DD).





**Remarque:** Assurez-vous que les petite vis Camloc (EE) que vous avez déjà installées sont entièrement enfoncées.

### Quincaillerie utilisée

<b>DD</b>	Attache Camloc		x 4
<b>FF</b>	Goujon de bois		x 5

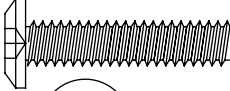
7. À partir de l'arrière de l'ensemble, fixez le panneau gauche de la base (F) au panneau arrière de la base (I) à l'aide de rondelles plates (CC), de rondelles de blocage (BB) et de boulons (AA). Serrez les boulons à l'aide de la clé hexagonale (RR).

### Quincaillerie utilisée

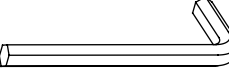
<b>AA</b>	Boulon		x 3
<b>BB</b>	Rondelle de blocage		x 3
<b>CC</b>	Rondelle plate		x 3
<b>DD</b>	Attache Camloc		x 1
<b>RR</b>	Clé hexagonale		x 1

### Assemblage de l'étagère

8. Insérez les petite vis Camloc (EE) dans le panneau gauche de l'étagère (A), dans le panneau droit de l'étagère (B) et dans le panneau supérieur de l'étagère (C).

### Quincaillerie utilisée

<b>EE</b>	Petite vis Camloc		x 10
-----------	-------------------	---	------

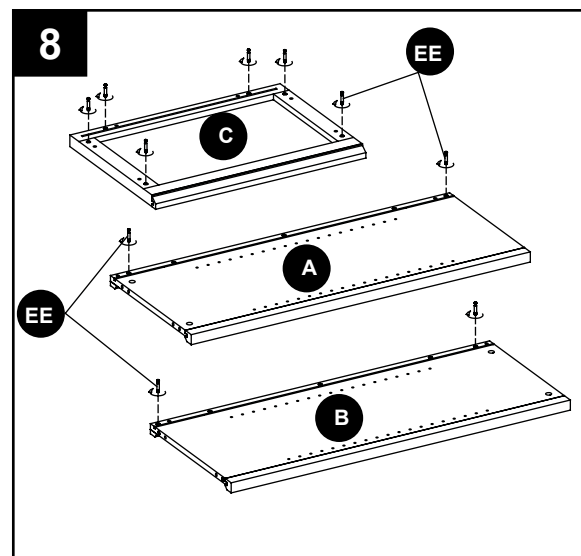
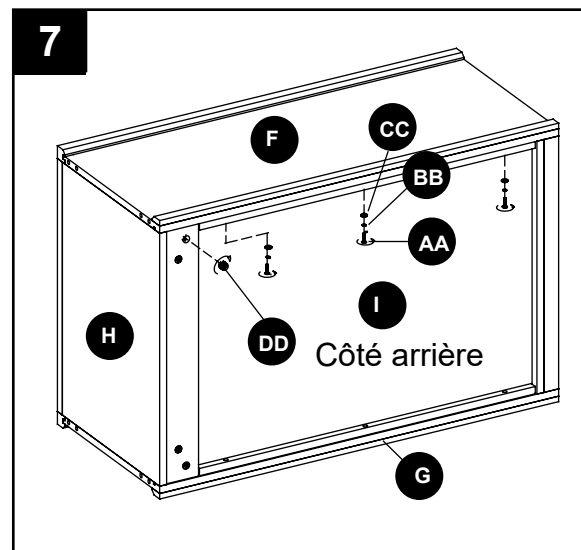
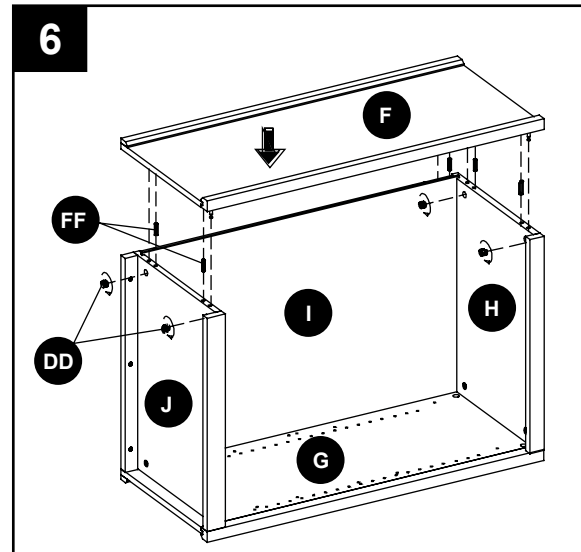





## INSTRUCTIONS POUR L'ASSEMBLAGE

9. Fixez le panneau gauche de l'étagère (A) et le panneau droit de l'étagère (B) au panneau arrière (D), de goujons de bois (FF) et de attaches Camloc (DD). À partir de l'arrière de l'ensemble, fixez solidement l'ensemble à l'aide rondelles plates (CC), de rondelles de blocage (BB) et de boulons (AA). Serrez les boulons à l'aide de la clé hexagonale (RR). Ensuite, fixez l'ensemble au moyen de attaches Camloc (DD).

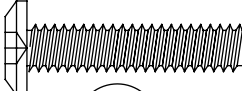

**Remarque:** Assurez-vous que les petite vis Camloc (EE) que vous avez déjà installées sont entièrement enfoncées.

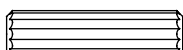
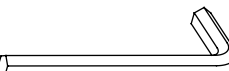
### Quincaillerie utilisée

<b>AA</b>	Boulon		x 6
<b>BB</b>	Rondelle de blocage		x 6
<b>CC</b>	Rondelle plate		x 6
<b>DD</b>	Attache Camloc		x 4
<b>FF</b>	Goujon de bois		x 4
<b>RR</b>	Clé hexagonale		x 1

10. Insérez des goujons en bois (FF) et de attaches Camloc (DD) dans l'ensemble de l'étagère. Installez le panneau supérieur de l'étagère (C), puis fixez-le en serrant les attaches Camloc (DD).

### Quincaillerie utilisée

<b>DD</b>	Attache Camloc		x 6
<b>FF</b>	Goujon de bois		x 6

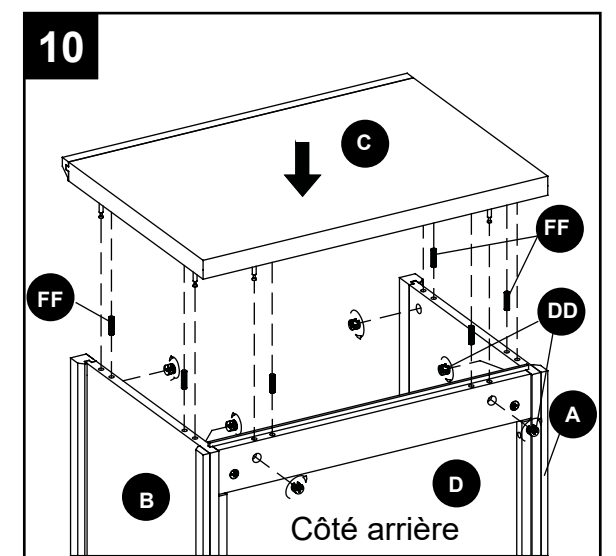
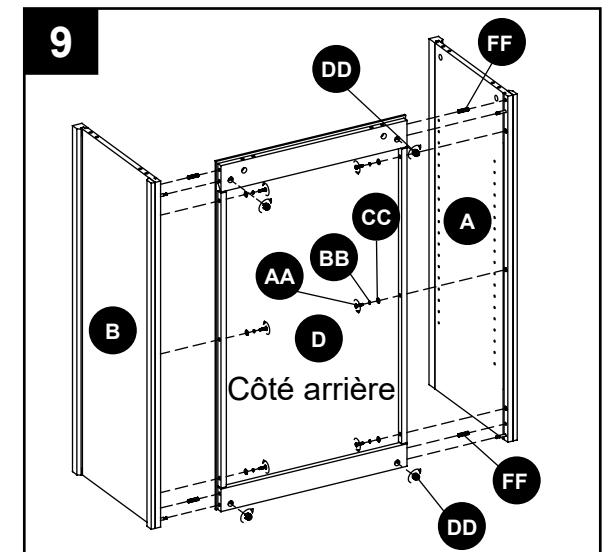

## INSTRUCTIONS POUR L'ASSEMBLAGE

11. Déposez soigneusement l'ensemble de l'étagère sur le côté. Insérez des écrous à portée cylindrique (QQ) et des grandes vis Camloc (PP) dans le bas de l'ensemble de l'étagère.

### Quincaillerie utilisée

**PP** Grande vis Camloc  x 4

**QQ** Écrou à portée cylindrique  x 4

12. Insérez des goujons de bois longs (FF) et des attaches Camloc (DD) dans le panneau gauche & droit de la base (F&G). Puis, avec l'aide d'une autre personne, installez l'ensemble de l'étagère sur l'ensemble de la base et fixez le tout en serrant les grandes attaches Camloc (DD).

**Remarque :** Assurez-vous que les grandes vis Camloc (PP) que vous avez déjà installées sont entièrement enfoncées.

### Quincaillerie utilisée

**DD** Attache Camloc  x 4

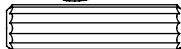
**FF** Goujon de bois  x 4

### Installation au mur

13. À l'aide d'un détecteur de montants, repérez les bordures des montants. Trouvez le centre de chaque montant et tracez une ligne de référence verticale sur le mur. Placez le gabarit pour l'installation (W) sur le mur à l'endroit désiré.

**Remarque:** Le bas du gabarit pour l'installation (W) devrait être à une distance minimale de 80,01 cm du plancher.

Marquez l'emplacement des trous à l'aide d'un crayon (non inclus) et enlevez le gabarit pour l'installation (W). Percez des avant-trous aux endroits marqués à l'aide d'un foret de 3/16 po. Puis, fixez les traverses de fixation au mur (O), le bord biseauté orienté vers le haut, à l'aide de grandes rondelles plates (QQ) et de tire-fonds (PP).

### Quincaillerie utilisée

**JJ** Tire-fond M8 de 2 1/2 po  x 4

**LL** Grande rondelle plate  x 4

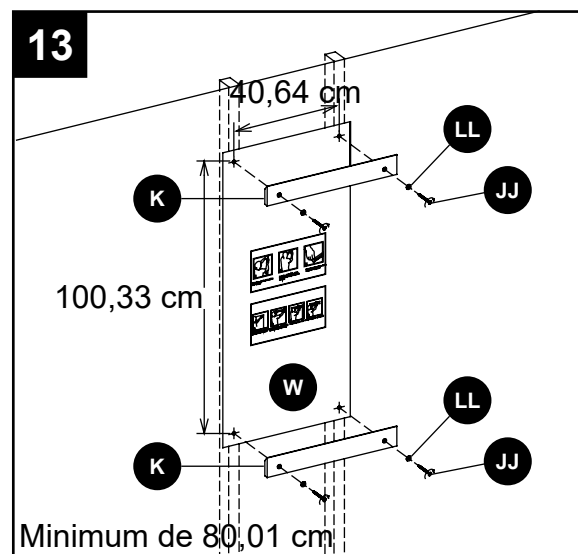
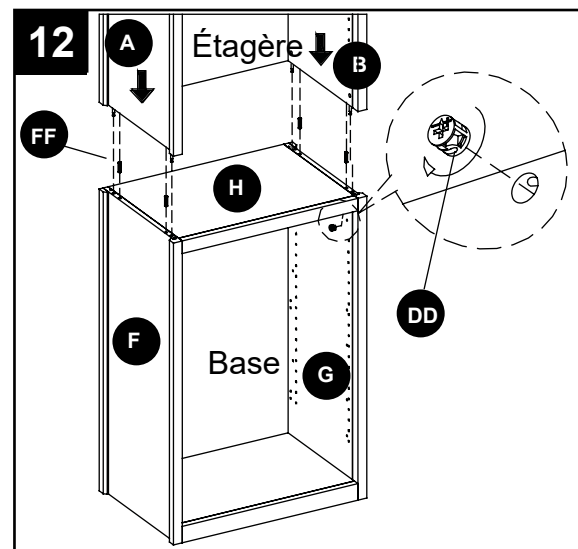
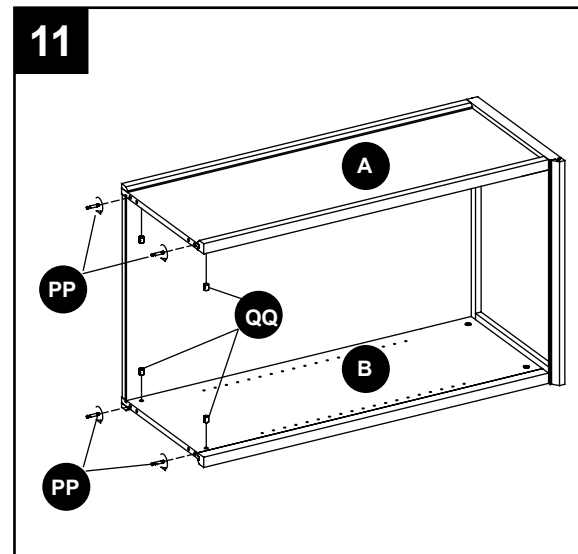

## INSTRUCTIONS POUR L'ASSEMBLAGE

15. Avec l'aide d'une autre personne, installez soigneusement l'ensemble sur les traverses de fixation au mur (K).

### Installation de la tablette longue

**Remarque:** Si la tablette longue (L) doit être coupée pour tenir à l'intérieur de votre placard, coupez uniquement une extrémité de la tablette. N'utilisez pas une scie à métaux. Nous vous recommandons de faire appel à un professionnel pour ce type d'installation.

16. À l'aide d'un crayon, tracez une ligne horizontale à la hauteur à laquelle vous souhaitez poser la tablette longue (L). En vous guidant à l'aide des supports en L (OO), marquez l'emplacement des trous de vis. Percez des avant-trous d'une profondeur d'au moins 6,35 cm aux endroits marqués à l'aide d'un foret d'un diamètre de 3/8 po, puis insérez-y les chevilles d'ancrage (NN) jusqu'à ce qu'elles soient complètement encastrées dans le mur. Fixez les supports en L au mur à l'aide de vis M4 de 38 mm (GG) et à la tablette longue (L) au moyen de vis à bois M4 de 14 mm (HH).

### Quincaillerie utilisée

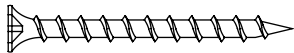
**GG** Vis M4 de 38 mm  x 8

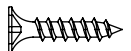
**HH** Vis à bois M4 de 14 mm  x 8

**NN** Cheville d'ancrage  x 8

**OO** Support en L  x 4

17. Fixez les tablettes longues (L) au panneau gauche de l'étagère (A) et au panneau droit de l'étagère (B) à l'aide de supports en L (OO), fixant le tout au moyen de vis à bois M4 de 14 mm (HH).

### Quincaillerie utilisée

**HH** M4 x 14 mm Wood Screw  x 16

**OO** Support en L  x 4

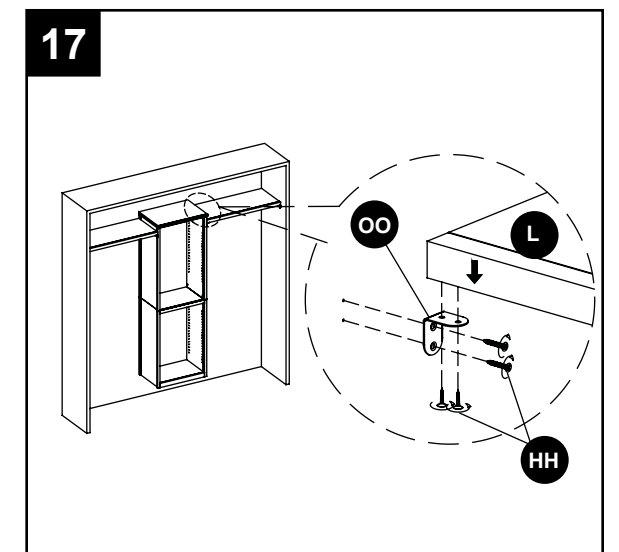
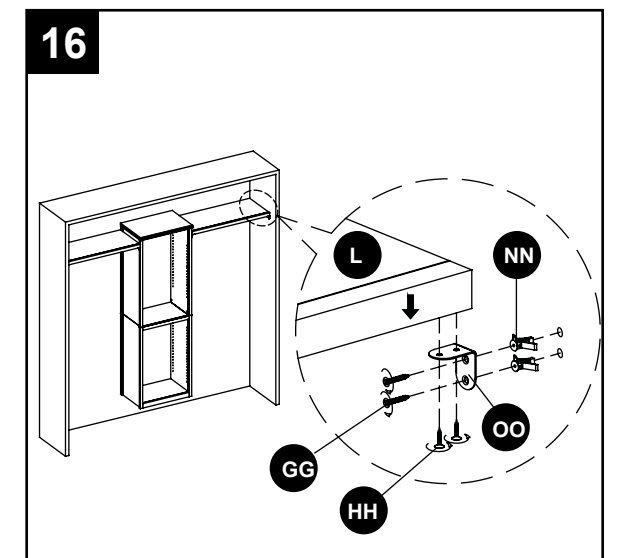
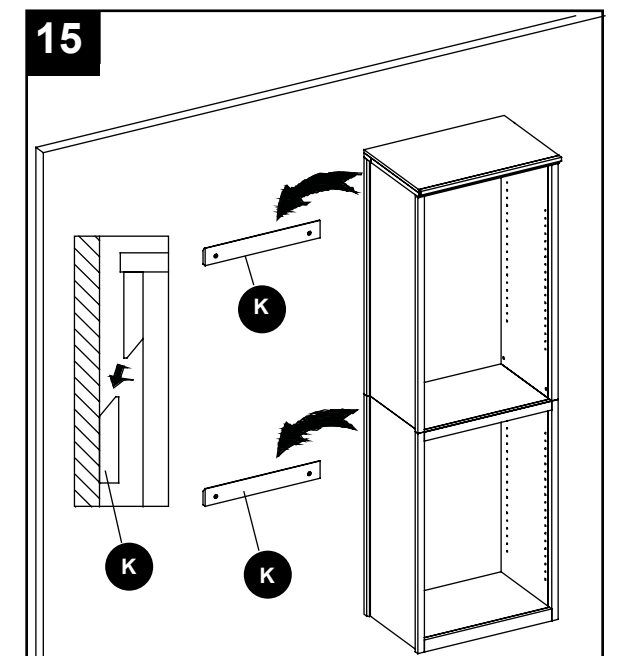

## INSTRUCTIONS POUR L'ASSEMBLAGE

### Installation des tringles

18. Insérez les tringles métalliques de 22 mm (X) dans les tringles métalliques de 25 mm (Y). En vous guidant à l'aide des supports à tringle fermés (ZZ), marquez l'emplacement des trous de vis. Percez des avant-trous d'une profondeur d'au moins 6,35 cm aux endroits marqués à l'aide d'un foret d'un diamètre de 3/8 po, puis insérez-y les chevilles d'ancrage pour cloison sèche (non incluses). Fixez les supports à tringle fermés (ZZ) à l'aide de vis M4 de 38 mm (KK). Insérez les tringles de 25 mm (Y) les supports à tringle fermés (ZZ) et fixez-les avec des vis autotaraudeuse M4 de 15 mm (AB)

**Remarque:** Les chevilles d'ancrage pour cloison sèche ne sont pas nécessaires si vous fixez les tringles à un montant.

#### Quincaillerie utilisée

**KK** Vis M4 de 38 mm  x 6

**ZZ** Support à tringle fermé  x 2

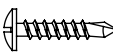
**AB** Vis autotaraudeuse M4 de 15 mm  x 2

19. Fixez les supports à tringle ouverts (YY) au panneau gauche de l'étagère (A) et au panneau droit de l'étagère (B), fixant le tout au moyen de vis à bois M4 de 14 mm (MM). Insérez les tringles de 22 mm (X) dans les supports à tringle ouverts (YY) et fixez-les avec des vis autotaraudeuse M4 de 15 mm (AB).

#### Quincaillerie utilisée

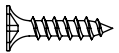
**MM** Vis à bois M4 de 14 mm  x 6

**YY** Support à tringle ouvert  x 2

**AB** Vis autotaraudeuse M4 de 15 mm  x 2

### Installation de la tablette réglable

20. Installez les taquets pour tablette (II) à la hauteur de votre choix dans l'étagère, puis placez la tablette réglable (E) dessus.

**Note:** Ensure the shelf pins (II) are level.

#### Quincaillerie utilisée

**II** Taquet pour tablette  x 8

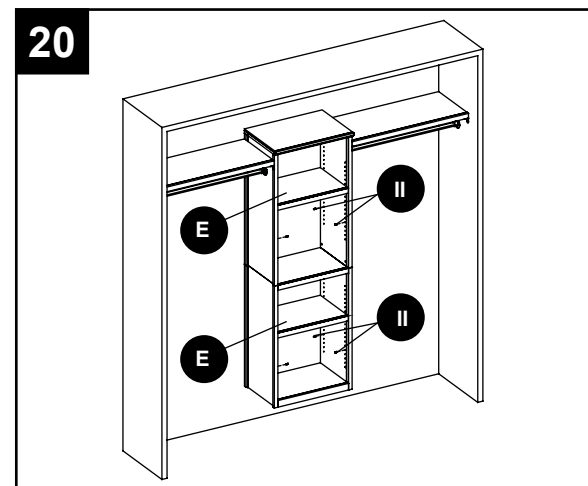
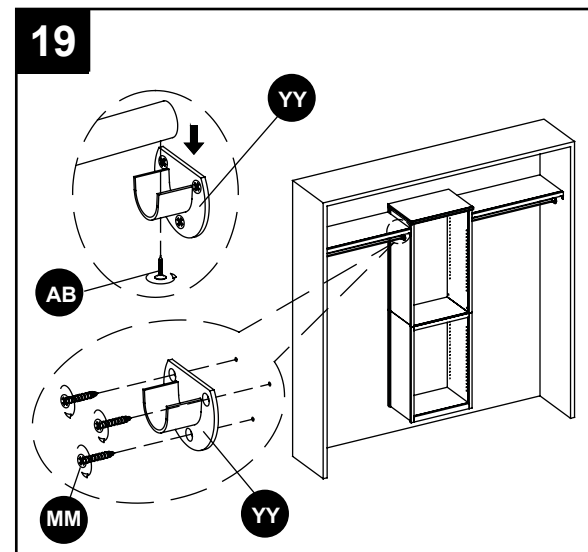
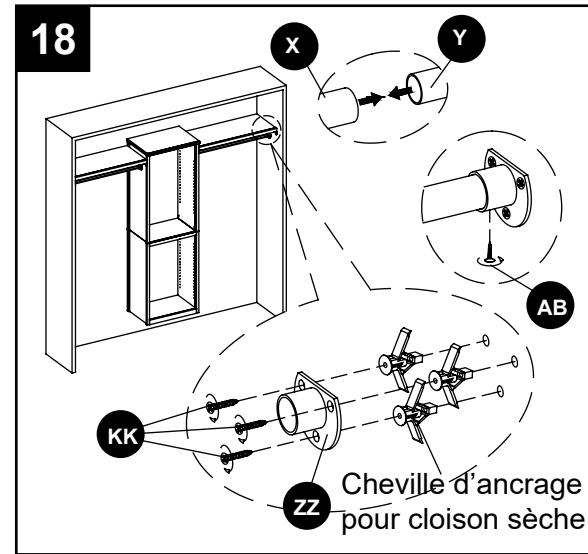

## ENTRETIEN

- Vérifiez périodiquement si les composants sont bien positionnés, en bon état et fermement montés.
- Utilisez un linge doux et propre qui n'égratignera pas la surface lorsque vous épousseterez l'article.
- N'utilisez jamais d'eau pour nettoyer l'article puisque vous risqueriez d'endommager le fini.
- Nettoyez l'article à l'aide d'un linge humide et d'un nettoyant doux. Essuyez-le à l'aide d'un linge propre.
- Si l'article est taché ou endommagé de quelque façon durant son utilisation, il est recommandé d'appeler un professionnel pour le faire réparer.
- Conservez l'article à l'abri du soleil pour éviter d'endommager le fini.
- Il est préférable que l'article soit gardé dans un endroit à température contrôlée. Les variations d'humidité et de température importantes peuvent décolorer, déformer, contracter et même fendre le bois.
- Un crayon à retouche (SS) est fourni (à l'exception de l'article #0339205) pour couvrir toute égratignure ou rayure qui pourrait survenir durant l'assemblage ou l'expédition.

## TROUBLESHOOTING

PROBLEME	POSSIBLE CAUSE	CORRECTIVE ACTION
Une extrémité de la tablette longue (L) flotte.	La largeur du placard est de plus de 2,44 m.	1. Achetez les supports pour tablette et les supports muraux correspondants (vendus séparément). 2. Remplacez la tablette longue (L) avec une plus longue d'un fini et d'un style similaires.
La tablette longue (L) ne peut être installée dans le placard.	La largeur du placard est de moins de 2,44 m.	1. Raccourcissez une extrémité de la tablette longue (L). Faites appel à un professionnel pour l'installation. 2. Remplacez la tablette longue (L) avec une plus courte d'un fini et d'un style similaires.
El estante está inclinado.	Las abrazaderas de pared y las abrazaderas para repisa no se instalaron al mismo nivel.	Use un nivel de calidad para asegurarse de que las abrazaderas estén niveladas.

## DÉPANNAGE

PROBLÈME	CAUSE POSSIBLE	MESURE CORRECTIVE
Une des extrémités de la tringle ne tient pas correctement sur le support à tringle ouvert (YY).	L'ouverture du support à tringle ouvert n'est pas orientée vers le haut (à la verticale).	Utilisez un bon niveau pour vous assurer que le bord plat du support à tringle ouvert est de niveau au moment de l'installation.
La tringle est inclinée.	Le support à tringle ouvert et le support à tringle fermé ne sont pas à la même hauteur.	Utilisez un bon niveau pour vous assurer que les supports à tringle sont à la même hauteur.
Une vis s'est enfoncée dans le panneau latéral.	Des vis à bois M4 de 38 mm ont été utilisées pour fixer le support à tringle au côté de l'étagère.	Utilisez des vis à bois M4 de 14 mm.
La tour de rangement de placard est inclinée.	Les traverses de fixation au mur ne sont pas de niveau.	Réinstallez les traverses de fixation au mur, puis assurez-vous qu'elles sont de niveau.
La tour de rangement ne s'installe pas au mur.	Les emplacements des trous de montage ne sont pas corrects.	Réinstallez les traverses de fixation au mur; assurez-vous que la distance entre les deux traverses est de 100,33 cm et que les deux trous de montage inférieurs se trouvent à une distance minimale de 80,01 cm du plancher.

## WARRANTY

La présente garantie n'est offerte qu'à l'acheteur initial (et ne s'applique pas aux tablettes). Si cet article présente des défauts de matériaux ou de fabrication, le fabricant choisira, à sa seule discrétion, de réparer ou de remplacer l'article sans frais. La garantie sera annulée si l'article a été assemblé incorrectement, a été utilisé de manière inappropriée ou abusive en le surchargeant ou en l'altérant d'une quelconque façon, ou a subi des dommages causés par un accident. La présente garantie est non transférable et ne couvre pas les ébréchures, l'écaillage, les égratignures, la rouille, les bosses et tout autre dommage à la surface de cet article. La responsabilité du fabricant se limite à la réparation et au remplacement de cet article. Le fabricant n'est pas responsable des dommages accessoires, consécutifs ou autres ni de toute perte causée par une défectuosité de l'article.

La présente garantie prévaut sur toute autre garantie explicite. Certains États ou certaines provinces ne permettent pas l'exclusion ou la limitation des dommages accessoires ou consécutifs, de sorte que la limitation ci-dessus peut ne pas s'appliquer à vous. Cette garantie vous confère des droits précis. Il est possible que vous disposiez d'autres droits, qui varient d'un État ou d'une province à l'autre.

### LISTE DES PIÈCES DE RECHANGE

Pour obtenir des pièces de rechange, communiquez avec notre service à la clientèle au 1 866 439-9800, entre 8 h et 20 h (HNE), du lundi au vendredi.

PIÈCE	DESCRIPTION	NO DE PIÈCE
A	Panneau gauche de l'étagère	*WSLCSCE/G/BW-01-HPL
B	Panneau droit de l'étagère	*WSLCSCE/G/BW-02-HPR
C	Panneau supérieur de l'étagère	*WSLCSCE/G/BW-03-HPT
D	Panneau arrière de l'étagère	*WSLCSCE/G/BW-04-HPB
E	Tablette réglable	*WSLCSCE/G/BW-05-AS
F	Panneau gauche de la base	*WSLCSCE/G/BW-06-BPL
G	Panneau droit de la base	*WSLCSCE/G/BW-07-BPR
H	Panneau supérieur de la base	*WSLCSCE/G/BW-08-BPT
I	Panneau arrière de la base	*WSLCSCE/G/BW-09-BPB
J	Panneau inférieur de la base	*WSLCSCE/G/BW-10-BPB
K	Traverse de fixation au mur	*WSLCSCE/G/BW-11-WHC
L	Tablette longue	*WSLCSCE/G/BW-12-LS
W	Gabarit pour l'installation	*WSLCSCE/G/BW-13-IT
X	Tringle métallique de 22 mm	*WSLCSCE/G/BW-14-22MP
Y	Tringle métallique de 25 mm	*WSLCSCE/G/BW-15-25MP



PART	DESCRIPTION	PART #
AA	Boulon	*WSLCSCE/G/BW-16-1 1/4B
BB	Rondelle de blocage	*WSLCSCE/G/BW-17-LW
CC	Rondelle plate	*WSLCSCE/G/BW-18-FW
DD	Attache Camloc	*WSLCSCE/G/BW-19-CL
EE	Petite vis Camloc	*WSLCSCE/G/BW-20-SCB
FF	Goujon de bois	*WSLCSCE/G/BW-21-WD
GG	Vis à bois M4 de 38 mm	*WSLCSCE/G/BW-22-38WS
HH	Vis à bois M4 de 14 mm	*WSLCSCE/G/BW-23-14WS
II	Taquet pour tablette	*WSLCSCE/G/BW-24-SP
JJ	Tire-fond M8 de 2 1/2 po	*WSLCSCE/G/BW-25-2 1/2LB
LL	Grande rondelle plate	*WSLCSCE/G/BW-26-LFW
NN	Cheville d'ancrage	*WSLCSCE/G/BW-27-WA
OO	Support en L	*WSLCSCE/G/BW-28-LB
PP	Grande vis Camloc	*WSLCSCE/G/BW-29-LCB
QQ	Écrou à portée cylindrique	*WSLCSCE/G/BW-30-BN
RR	Clé hexagonale M4	*WSLCSCE/G/BW-31-M4AW
SS	Crayon à retouche	*WSLCSCE/G/BW-32-TUP
MM	Vis à bois de zinc M4 de 14 mm	*WSLCSCE/G/BW-33-14ZWS
YY	Support à tringle ouvert	*WSLCSCE/G/BW-34-OPH
ZZ	Support à tringle fermé	*WSLCSCE/G/BW-35-CPH
AB	Vis autotaraudeuse M4 de 15 mm	*WSLCSCE/G/BW-36-15SS
KK	Vis de zinc M4 de 38 mm	*WSLCSCE/G/BW-37-38ZS
	Quincaillerie complète	*WSLCSCE/G/BW-38-CH
	Quincaillerie complète pour la trousse de tringle	*WSLCSCE/G/BW-39-CHFPK

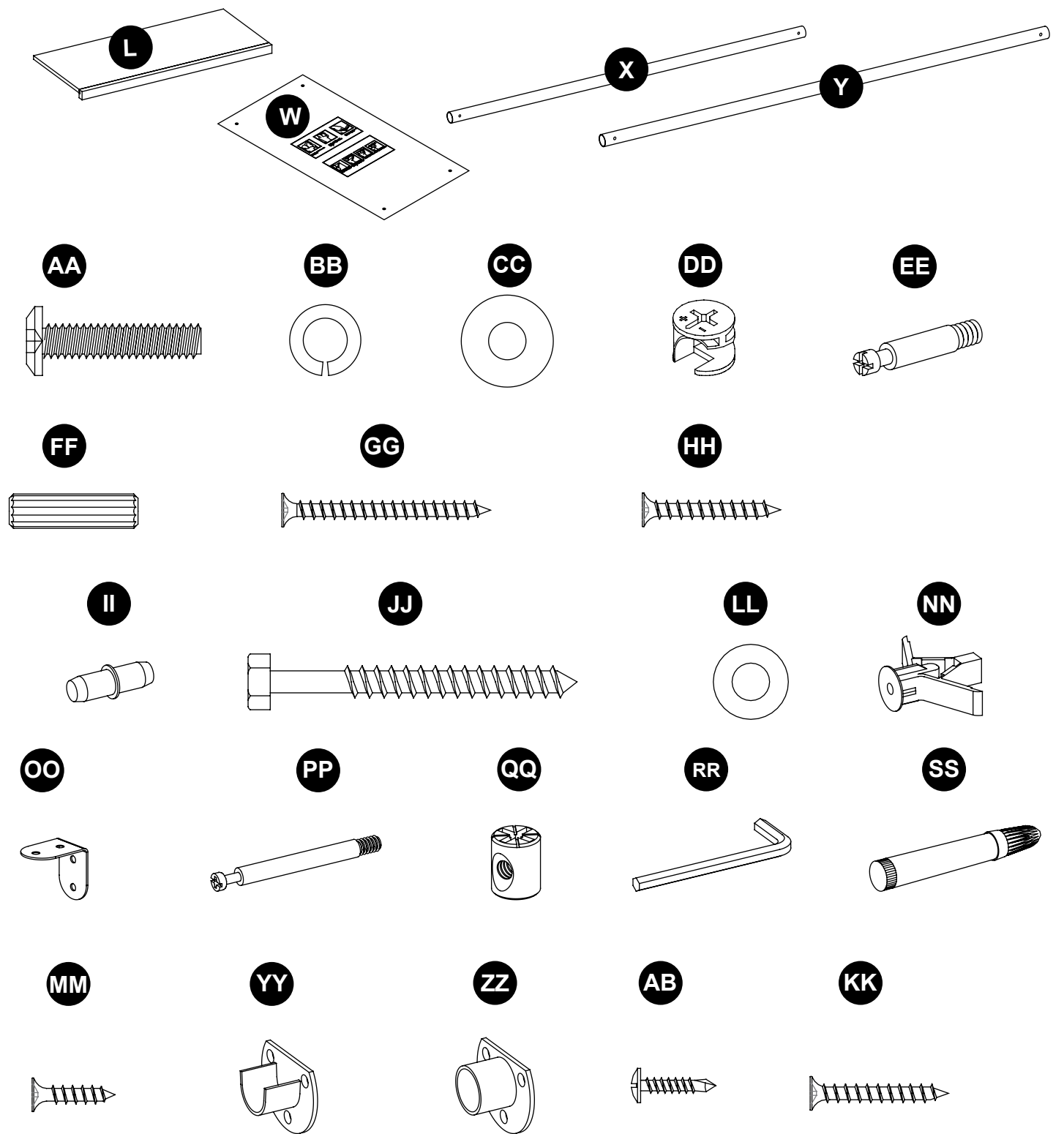
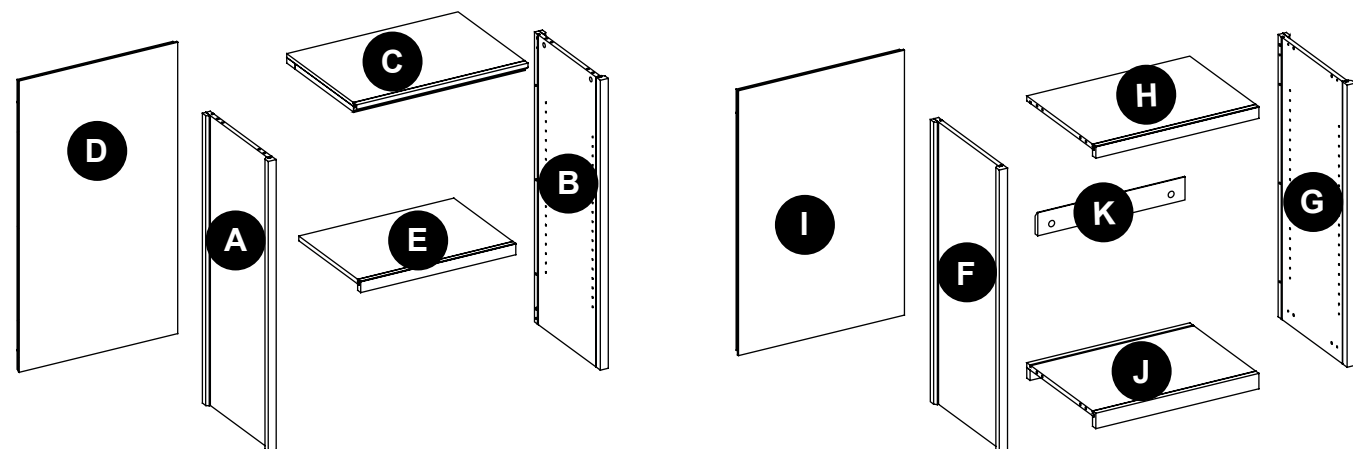

Date: 2018-03-07 Rév. 0001-A  
Fabricant # MEIFUR

Printed in Vietnam

allen + roth® is a registered trademark  
of LF, LLC. All Rights Reserved.



allen + roth®

welcoming • sophisticated • inspiring

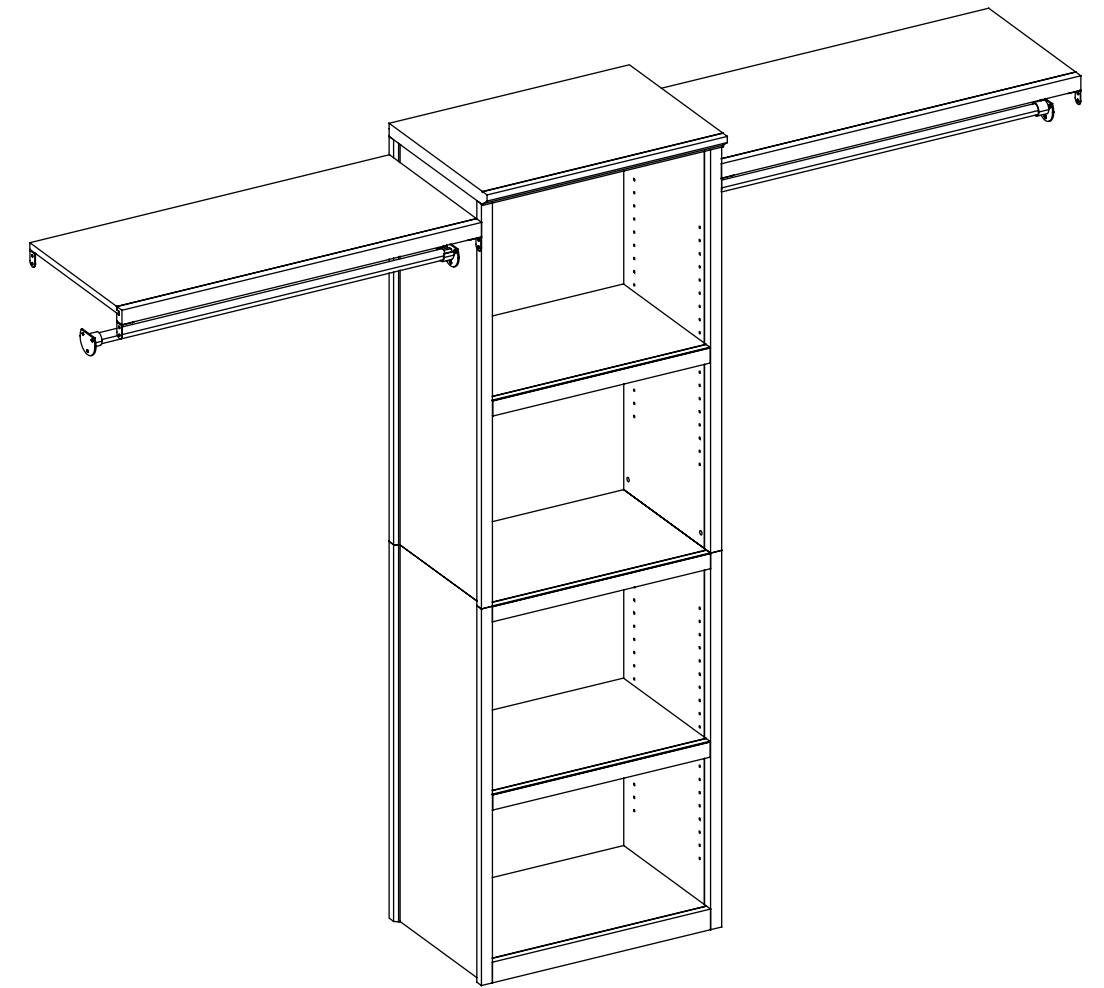

allen + roth® es una marca registrada de LF, LLC. Todos los derechos reservados.

ARTÍCULOS #1029488, 1029489, 1029490

## KIT RESISTENTE PARA ARMARIO

MODELOS #WSLCSCE, WSLCSCG, WSLCSCBW

ADJUNTE SU RECIBO AQUÍ

Número de serie \_\_\_\_\_ Fecha de compra \_\_\_\_\_

¿Preguntas, problemas, piezas faltantes? Antes de volver a la tienda, llame a nuestro Departamento de Servicio al Cliente al 1-866-439-9800, de lunes a viernes de 8 a.m. a 8 p.m., hora estándar del Este.

## ÍNDICE

Funcionamiento del sistema de cerrojo de leva.....	36
Contenido del paquete.....	37
Aditamentos.....	38
Información de seguridad.....	39
Preparación.....	40
Instrucciones de ensamblaje.....	40
Cuidado y mantenimiento .....	47
Solución de problemas.....	47
Garantía.....	49
Lista de piezas de repuesto .....	49

## FUNCIONAMIENTO DEL SISTEMA DE CERROJO DE LEVA

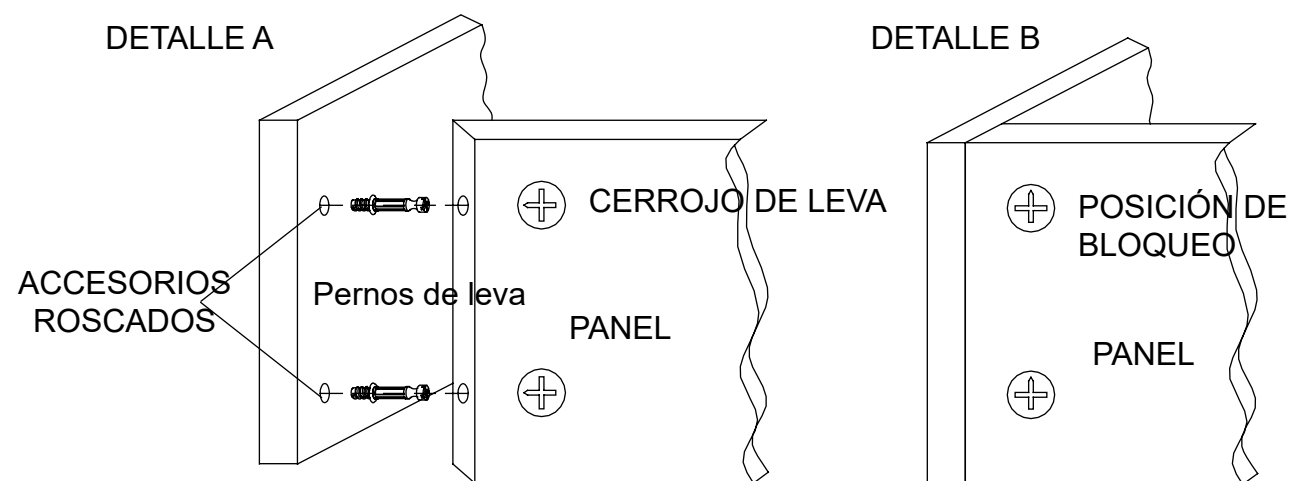





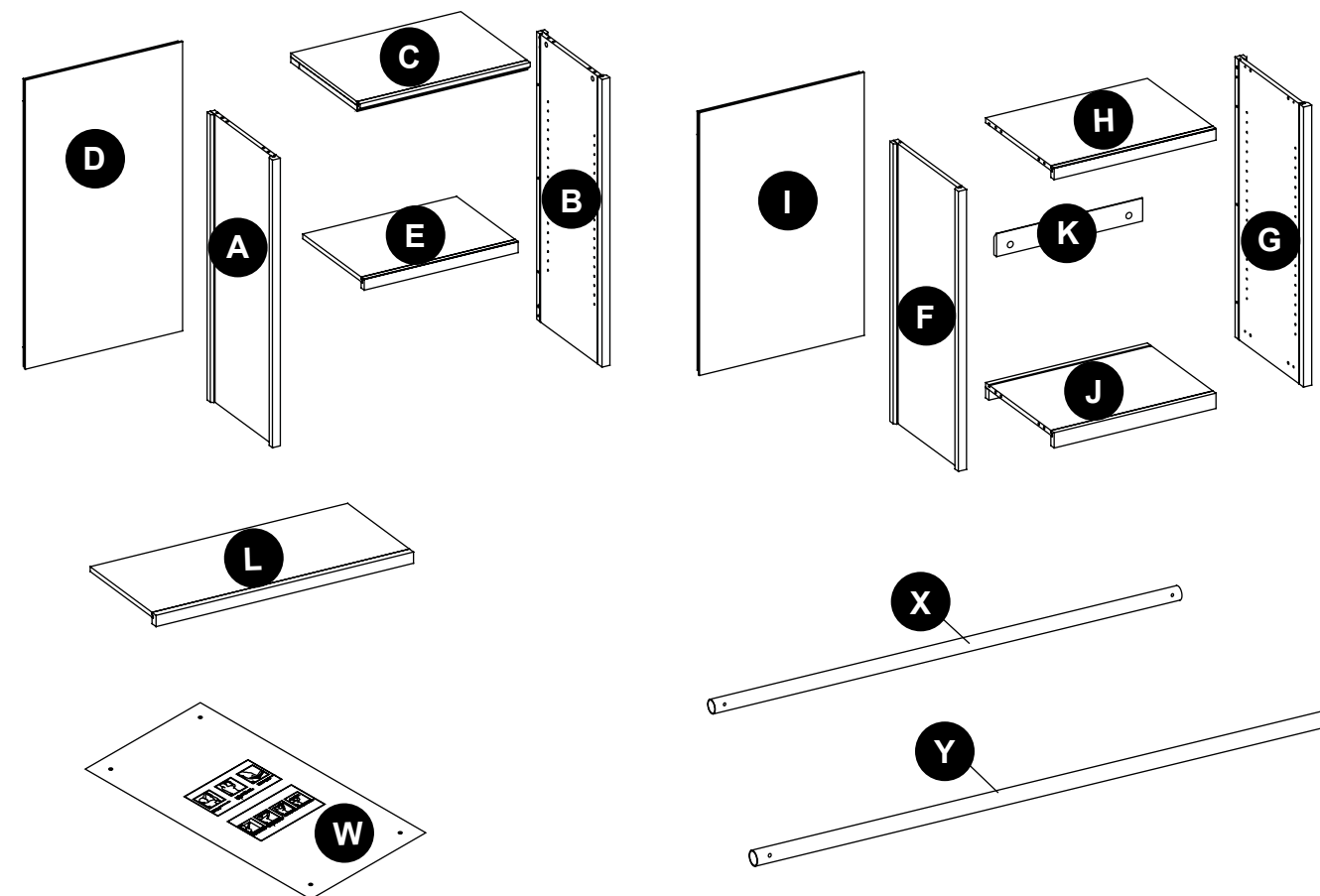

1. Atornille los pernos de leva a los orificios pequeños pretaladrados en el panel.
2. Introduzca el cerrojo de leva al orificio pretaladrado grande en el panel.
3. Asegúrese de que la flecha en el cerrojo de leva señale a los pernos de leva.
4. Una ambos paneles, y asegúrese de que los pernos de leva vayan dentro del orificio pretaladrado en el extremo del panel con cerrojo de leva.
5. Una vez que los pernos de leva estén conectados dentro del cerrojo de leva, tome el destornillador Phillips y apriete el cerrojo de leva en dirección de las manecillas del reloj.

## CONTENIDO DEL PAQUETE

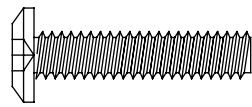
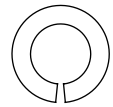
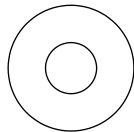
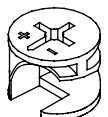
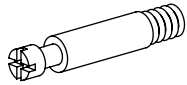

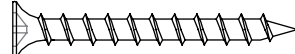
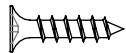

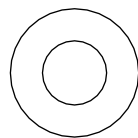
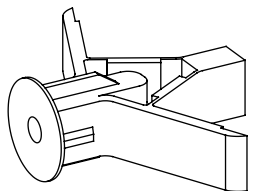
PIEZA	DESCRIPCIÓN	CANTIDAD	PIEZA	DESCRIPCIÓN	CANTIDAD
A	Panel de repisa izquierdo	1	K	Listón de colgante para pared	2
B	Panel de repisa derecho	1	L	Estante largo	2
C	Panel de repisa superior	1	W	Plantilla de instalación	1
D	Panel de repisa posterior	1	X	Varilla de metal de 22 mm	2
E	Estante ajustable	2	Y	Varilla de metal de 25 mm	2
F	Panel de base izquierdo	1			
G	Panel de base derecho	1			
H	Panel de base superior	1			
I	Panel de base posterior	1			
J	Panel de base inferior	1			

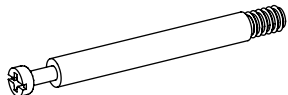
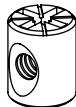
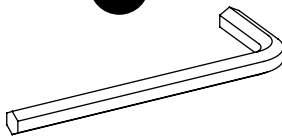
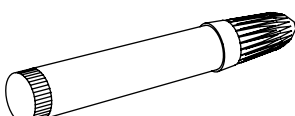
**ADITAMENTOS (no se muestran en tamaño real)**

<b>AA</b>	<b>BB</b>	<b>CC</b>	<b>DD</b>	<b>EE</b>
				
Perno de 1/4 x 1-1/4 pulg	Arandela de seguridad	Arandela plana	Cerrojo de leva	Perno de leva pequeño
Cant. 12	Cant. 12	Cant. 12	Cant. 26	Cant. 22
<b>FF</b>	<b>GG</b>	<b>HH</b>	<b>II</b>	
				
Espiga de madera	Tornillo para madera M4 x 38 mm	Tornillo para madera M4 x 14 mm	Pasador de estante	
Cant. 26	Cant. 8	Cant. 24	Cant. 8	
<b>JJ</b>	<b>LL</b>	<b>NN</b>	<b>OO</b>	
				
Tirafondo M8 x 2-1/2 pulg	Arandela plana grande	Ancla de expansión de pared	Abrazadera en L	
Cant. 4	Cant. 4	Cant. 8	Cant. 8	
<b>PP</b>	<b>QQ</b>	<b>RR</b>	<b>SS</b>	
				
Perno de leva grande	Tuerca cilíndrica	Llave de tuercas Allen M4	Aplicador de retoque	
Cant. 4	Cant. 4	Cant. 1	Cant. 1 (no incluido para color blanco)	

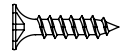
**ADITAMENTOS (juego para el poste)**

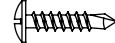
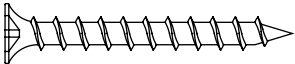
<b>MM</b>	<b>YY</b>	<b>ZZ</b>	<b>AB</b>	<b>KK</b>
				
Tornillo para madera de zinc M4 x 14 mm	Soporte de varilla abierto	Soporte de varilla cerrado	Tornillo autorroscante M4 x 15 mm	Tornillo de zinc M4 x 38 mm
Cant. 6	Cant. 2	Cant. 2	Cant. 4	Cant. 6

**! INFORMACIÓN DE SEGURIDAD**

Lea y comprenda completamente este manual antes de intentar ensamblar, usar o instalar el producto.

- No permita que los niños se suban al producto o que jueguen cerca de él.
- Para evitar daños, ensamble este producto sobre una superficie segura, nivelada y resistente.
- Dos o más personas deben trabajar en conjunto para instalar la unidad en la pared.
- Asegúrese de que todos los pernos/tornillos estén bien apretados antes de usar la unidad.
- Revise periódicamente los tornillos/pernos y apriételos si es necesario.

**! ADVERTENCIA**

- ESTA UNIDAD ESTÁ DISEÑADA PARA UTILIZARSE SOLO CON EL PESO MÁXIMO ESPECIFICADO. EL USO CON PRODUCTOS QUE SUPEREN EL PESO MÁXIMO ESPECIFICADO PUEDE PRODUCIR INESTABILIDAD Y CAUSAR POSIBLES LESIONES. DISTRIBUYA EL PESO DE MANERA UNIFORME.
- Carga máxima de la repisa: 30 lb/13,61 kg
- Carga máxima de la varilla: 40 lb/18,14 kg
- Longitud máxima de la varilla: 60 pulg/152,4 cm

**PRECAUCIÓN**

- Use esta unidad solo para el fin para el cual se diseñó.
- No utilice los estantes como escalera de tijera.

## PREPARACIÓN

Antes de comenzar a ensamblar el producto, asegúrese de tener todas las piezas. Compare las piezas con la lista del contenido del paquete y la lista de aditamentos. No intente ensamblar el producto si falta alguna pieza o si estas están dañadas.

**Tiempo estimado de ensamblaje:** 120 minutos

Herramientas necesarias para el ensamblaje (no se incluyen): destornillador Phillips, taladro eléctrico, broca para taladro de 3/16 pulg, broca para taladro de 3/8 pulg, llave de tuercas, nivel, detector de vigas, lápiz para marcar, cinta métrica, escalera de tijera, y martillo.

### Ensamblaje de la base

1. Foloque los pernos de leva pequeños (EE) en el panel de base izquierdo (F), el panel de base derecho (G) y el panel de base superior (H).

#### Aditamentos usados

**EE** Perno de leva pequeño  x 12

2. Fije el panel de base posterior (I) y el panel de base superior (H) al ensamblaje con las espigas de madera (FF) y el cerrojo de leva (DD).

**Nota:** asegúrese de que los pernos de leva pequeños (EE) previamente insertados estén totalmente asentados.

#### Aditamentos usados

**DD** Cerrojo de leva  x 2

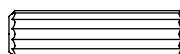
**FF** Espiga de madera  x 2

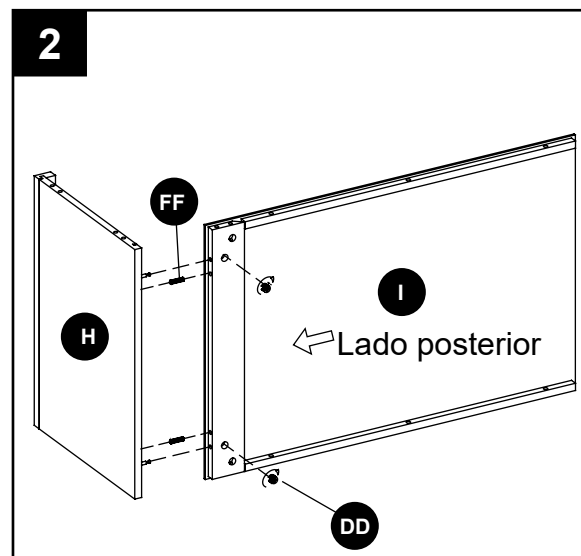
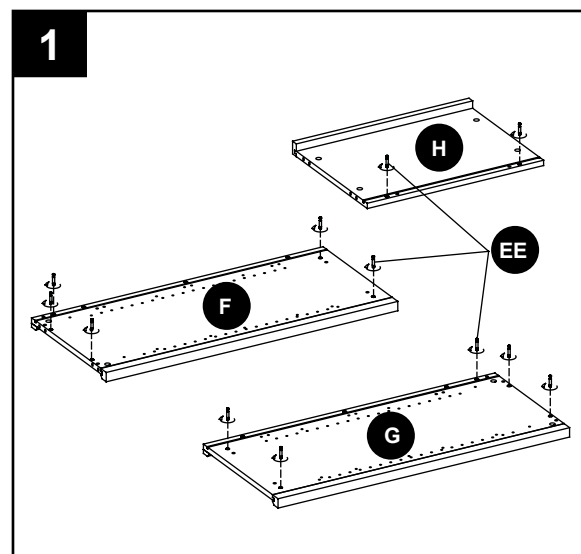

## INSTRUCCIONES DE ENSAMBLAJE

3. Fije el panel de base derecho (G) al ensamblaje con las espigas de madera (FF) y los cerrojos de leva (DD).

**Nota:** asegúrese de que los Perno de leva pequeño (EE) previamente insertados estén totalmente asentados.

#### Aditamentos usados

**DD** Cerrojo de leva  x 2

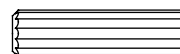
**FF** Espiga de madera  x 3

4. En la parte posterior del ensamblaje, fije el panel de base derecho (G) al panel de base posterior (I) con arandelas planas (CC), arandelas de seguridad (BB) y pernos (AA). Apriételos con una llave de tuercas Allen (RR).

#### Aditamentos usados

**AA** Perno  x 3

**BB** Arandela de seguridad  x 3

**CC** Arandela plana  x 3

**DD** Cerrojo de leva  x 1

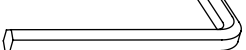
**RR** Llave de tuercas Allen  x 1

5. Coloque el panel de base posterior (I) en de la ranura del panel de base inferior (J). Luego, fije el panel de base inferior (J) al ensamblaje con las espigas de madera (FF) y los cerrojos de leva (DD).

**Nota:** asegúrese de que los pernos de leva pequeños (EE) previamente insertados estén totalmente asentados.

#### Aditamentos usados

**DD** Cerrojo de leva  x 2

**FF** Espiga de madera  x 2

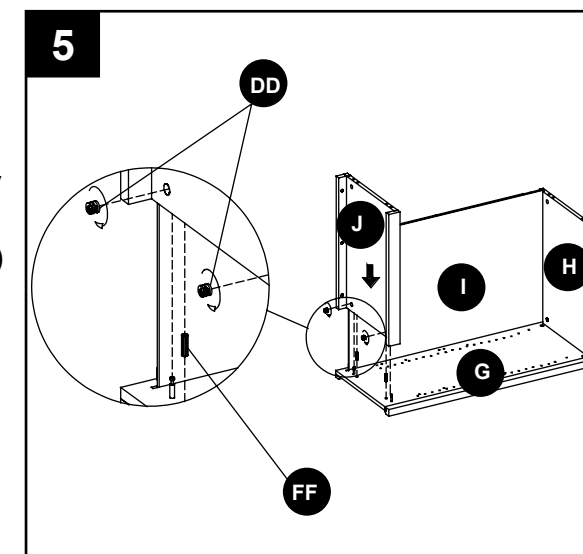
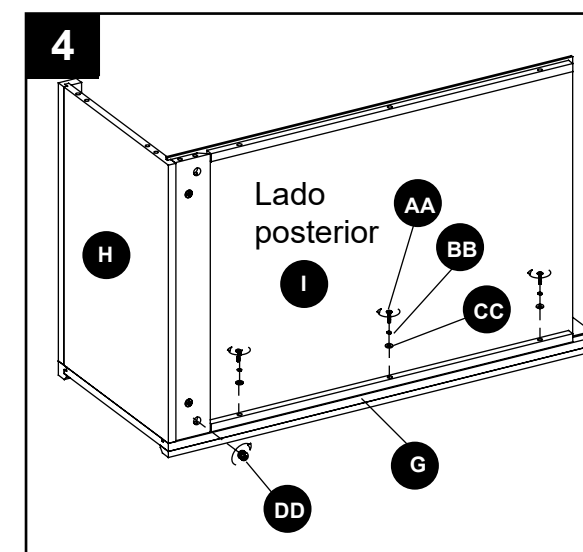
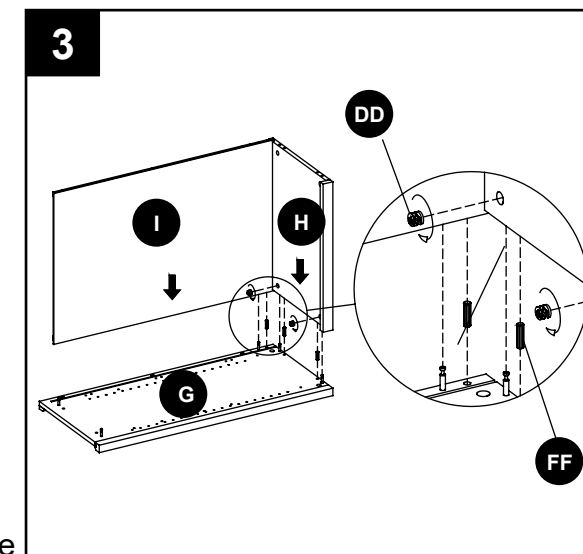

## INSTRUCCIONES DE ENSAMBLAJE

6. Fije el panel de base izquierdo (F) al ensamblaje con las espigas grandes de madera (FF) y los cerrojos de leva grandes (DD).



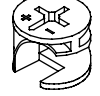
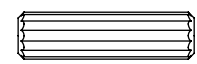

**Nota:** asegúrese de que los pernos de leva pequeños (EE) previamente insertados estén totalmente asentados.

### Aditamentos usados

- DD** Cerrojo de leva  x 4
- FF** Espiga de madera  x 5

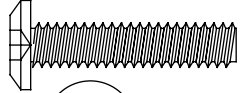
7. En la parte posterior del ensamblaje, fije el panel de base izquierdo (F) al panel de base posterior (I) con las arandelas planas (CC), arandelas de seguridad (BB) y pernos (AA). Apriételos con una llave de tuercas Allen (RR).

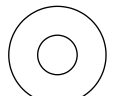
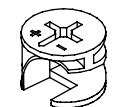
### Aditamentos usados

- AA** Perno  x 3
- BB** Arandela de seguridad  x 3
- CC** Arandela plana  x 3
- DD** Cerrojo de leva  x 1
- RR** Llave de tuercas Allen  x 1

### Ensamblaje de la repisa

8. Inserte los pernos de leva pequeños (EE) en el panel de repisa izquierdo (A) y el panel de repisa derecho (B) y el panel de repisa superior (C).

### Aditamentos usados

- EE** Perno de leva pequeño  x 10

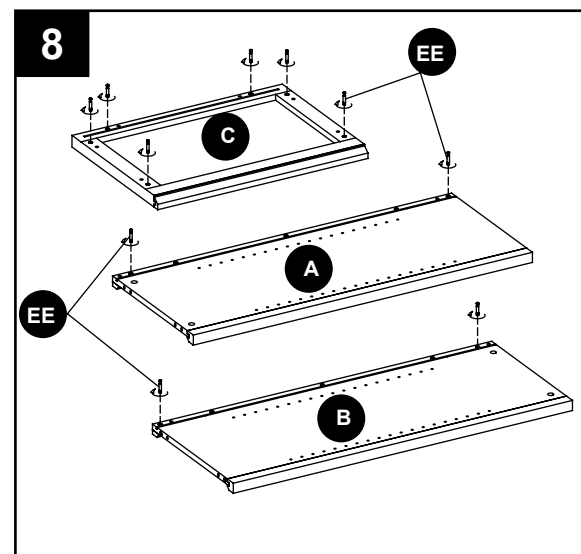
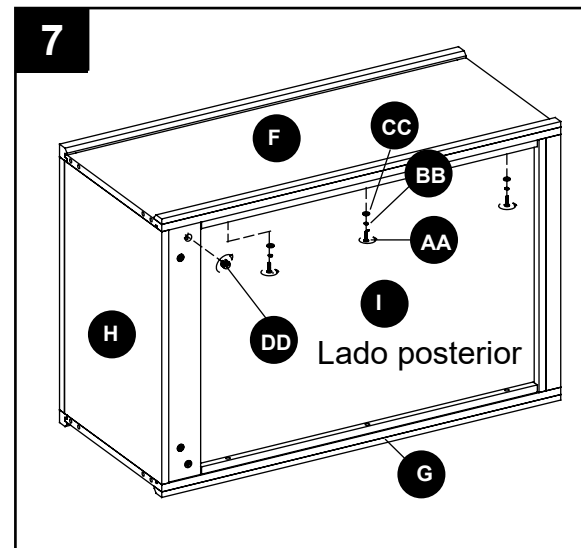
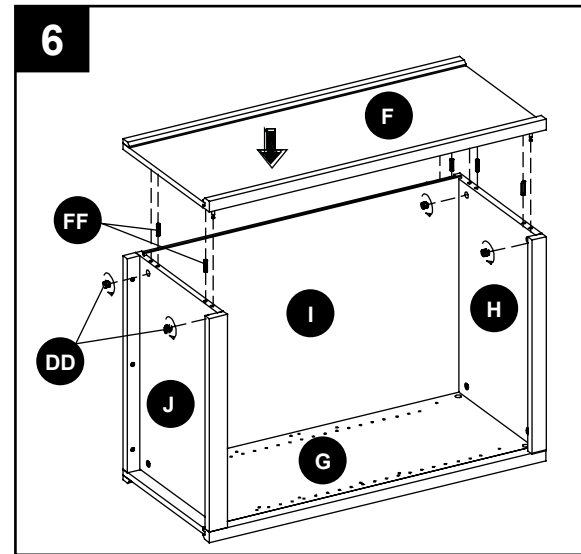



## INSTRUCCIONES DE ENSAMBLAJE

9. Fije el panel de repisa izquierdo (A) y el panel de repisa derecho (B) al panel de repisa posterior (D) con espigas de madera (FF) y cerrojos de leva (DD). En la parte posterior del ensamblaje, use las arandelas planas (CC), las arandelas de seguridad (BB) y los pernos (AA) para asegurar la unidad. Apriételos con una llave de tuercas Allen (RR). Luego, asegure el ensamblaje con cerrojos de leva (DD).

**Nota:** asegúrese de que los pernos de leva pequeños (EE) previamente insertados estén totalmente asentados.

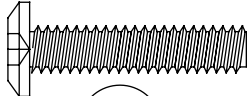
### Aditamentos usados

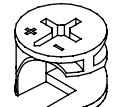
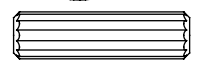
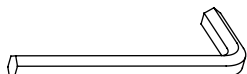
- AA** Perno  x 6
- BB** Arandela de seguridad  x 6
- CC** Arandela plana  x 6
- DD** Cerrojo de leva  x 6
- FF** Espiga de madera  x 6
- RR** Llave de tuercas Allen  x 1

10. Inserte las espigas de madera (FF) y los cerrojos de leva (DD) en el ensamblaje de la repisa. Fije el panel de repisa superior (C), y apriete los cerrojos de leva (DD) para que el ensamblaje quede seguro.

### Aditamentos usados

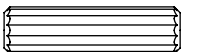
- DD** Cerrojo de leva  x 6
- FF** Espiga de madera  x 6

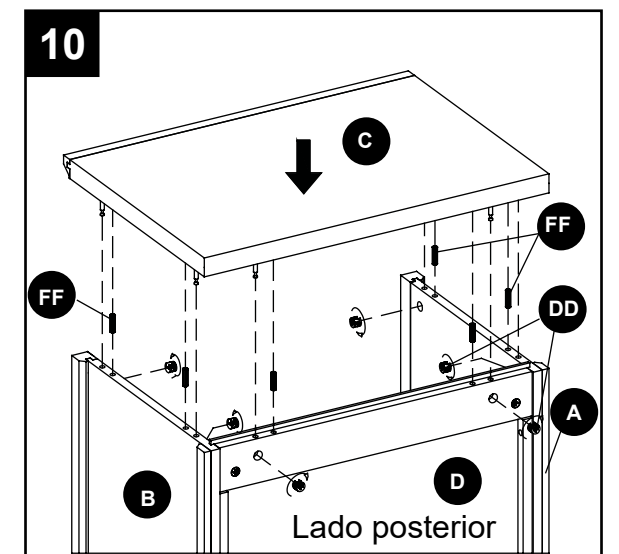
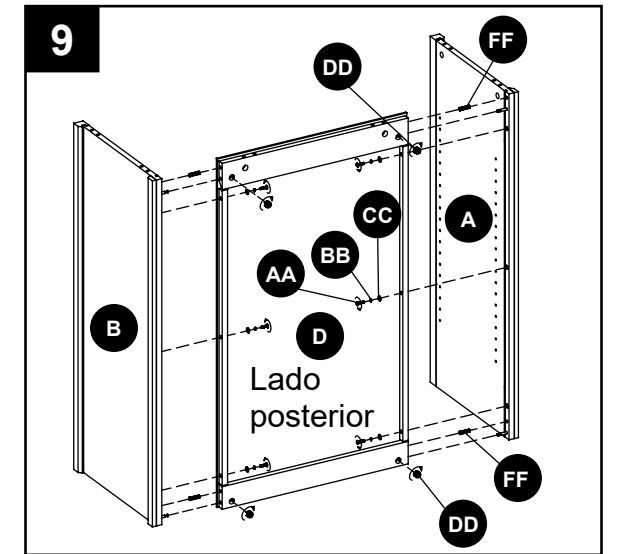



## INSTRUCCIONES DE ENSAMBLAJE

11. Cuidadosamente, apoye el ensamblaje de la repisa de costado. Inserte las tuercas cilíndricas (QQ) y los pernos de leva grandes (PP) en la parte inferior del ensamblaje de la repisa.

### Aditamentos usados

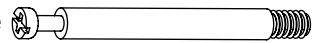
**PP** Perno de leva grande  x 4

**QQ** Tuerca cilíndrica  x 4

12. Coloque las espigas de madera (FF) y los cerrojos de leva (DD) en el panel de base izquierdo & derecho (F&G). Luego, con la ayuda de otra persona, fije el ensamblaje de la repisa al ensamblaje de la base, y apriete los cerrojos de leva grandes (DD) para asegurar la unidad.

**Nota:** asegúrese de que los pernos de leva grandes (PP) previamente insertados estén totalmente asentados.

### Aditamentos usados

**DD** Cerrojo de leva  x 4

**FF** Espiga de madera  x 4

### Instalación colgante para pared

13. Con un detector de vigas, localice los bordes de las vigas de madera. Localice la línea central de cada viga y trace una línea vertical como referencia en la pared sobre cada una. Coloque la plantilla de instalación (W) en el lugar que desee de la pared.

**Nota:** la parte inferior de la plantilla de instalación (W) debe quedar a no más de 31-1/2 pulg/80,01 cm del piso. Marque orificios de montaje con un lápiz (no se incluye) y deseche la plantilla de instalación (W). Taladre orificios guía de 3/16 pulg/0,48 cm en las ubicaciones marcadas. Luego, con el borde biselado hacia arriba, fije el listón de colgante para pared (K) con arandelas planas grandes (LL) y tirafondos (JJ).

### Aditamentos usados

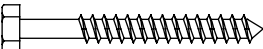
**JJ** Tirafondo M8 x 2-1/2 pulg 

**LL** Arandela plana grande  x 4

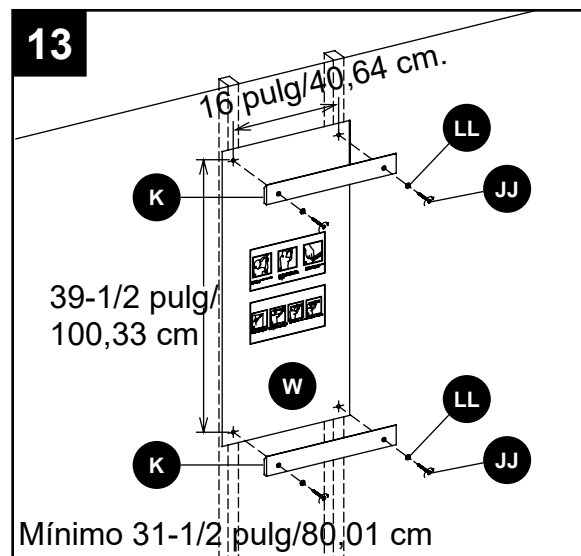
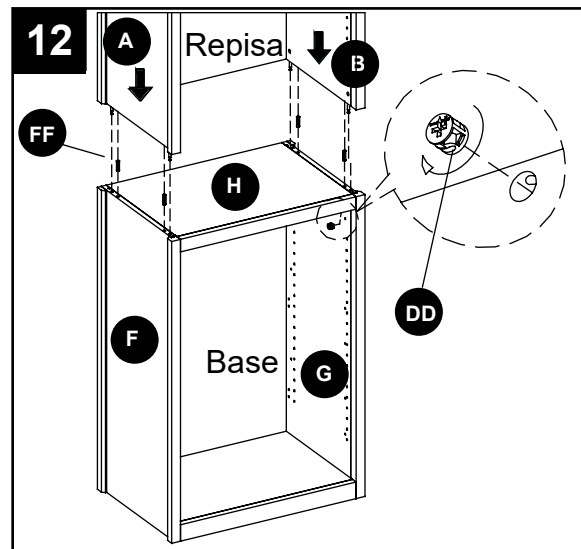
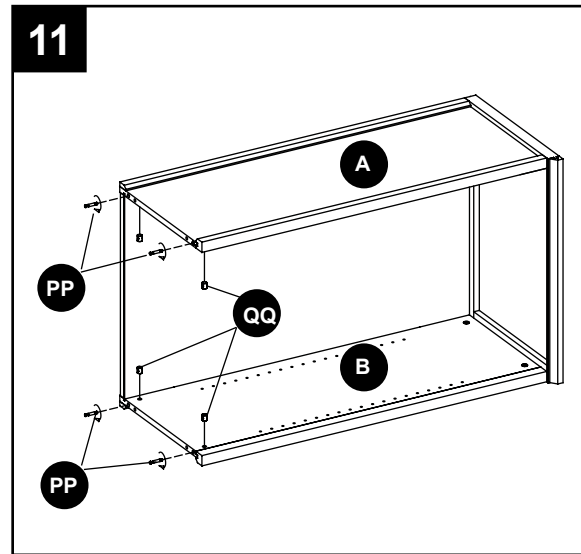

## INSTRUCCIONES DE ENSAMBLAJE

15. Con la ayuda de otra persona, cuidadosamente cuelgue la unidad sobre el listón de colgante para pared (K).

### Instalación de los estantes largos

**Nota:** si necesita cortar el estante largo (L) para adaptarlo al espacio del armario, solo corte un lado del estante. No use una sierra de mano. Se recomienda que contrate a un remodelador asegurado para este tipo de instalación.

16. Con un lápiz, trace una línea en la ubicación de montaje deseada para el estante largo (L). Use las abrazaderas en L (OO) como una guía, marque con un lápiz las ubicaciones para los orificios de los tornillos. Taladre orificios guía de 3/8 pulg/0,95 cm de diámetro al menos a una profundidad de 2-1/2 pulg/6,35 cm en las ubicaciones marcadas. Luego, introduzca las anclas de expansión de pared (NN) en los orificios hasta que queden al ras de la pared. Fije las abrazaderas en L (OO) a la pared con tornillos M4 x 38 mm (GG) y al estante largo (L) fíjelo con tornillos para madera M4 x 14 mm (HH).

### Aditamentos usados

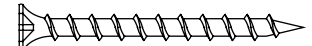
**GG** Tornillo M4 x 38 mm  x 8

**HH** Tornillo para madera M4 x 14 mm  x 8

**NN** Ancla de expansión de pared  x 8

**OO** Abrazadera en L  x 4

17. Fije los estantes largos (L) al panel de repisa izquierda (A) y al panel de repisa derecha (B) con las abrazaderas en L (OO), y asegúrelas con tornillos para madera M4 x 14 mm (HH).

### Aditamentos usados

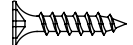
**HH** Tornillo para madera M4 x 14 mm  x 16

**OO** Abrazadera en L  x 4

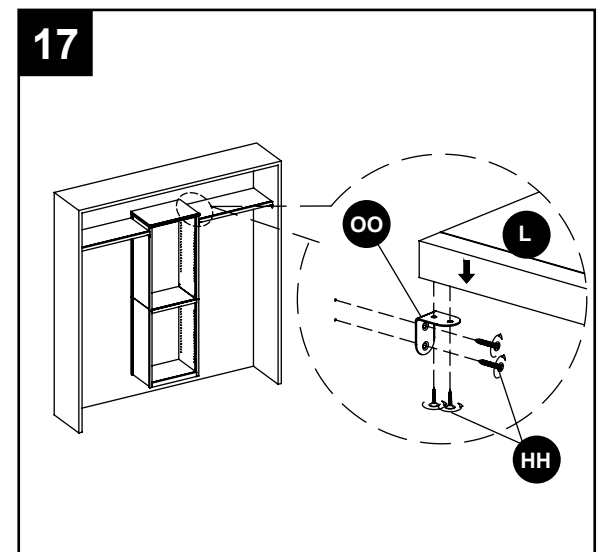
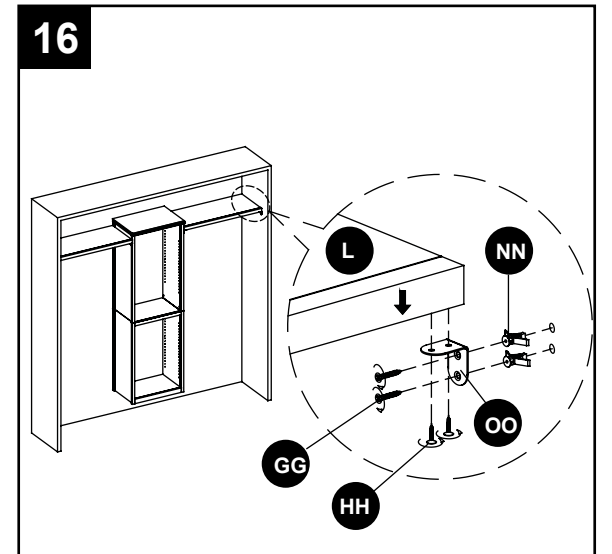
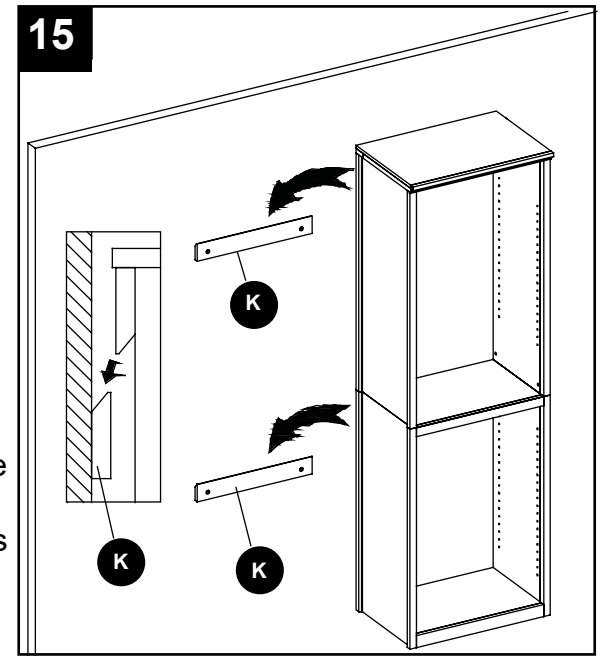

## INSTRUCCIONES DE ENSAMBLAJE

### Instalación de las varillas

18. Inserte las varillas de metal de 22 mm (X) en las varillas de metal de 25 mm (Y). Con los soportes de varilla cerrados (ZZ) como guía, marque con un lápiz las ubicaciones de los orificios de los tornillos. Taladre orificios guía de 3/8 pulg/0,95 cm de diámetro al menos a una profundidad de 2-1/2 pulg/6,35 cm en las ubicaciones marcadas. Luego, introduzca anclas de expansión para panel de yeso (no se incluyen) en los orificios. Fije los soportes de varilla cerrados (ZZ) con tornillos M4 x 38 mm (KK). Inserte las varillas de metal de 25 mm (Y) en los soportes de varilla cerrados (ZZ), y asegúrelos con tornillos autorroscantes M4 x 15 mm (AB).

**Nota:** si realiza la instalación en una viga, no necesita utilizar las anclas de expansión para panel de yeso.

### Aditamentos usados

**KK** Tornillo M4 x 38 mm x 6

**ZZ** Soporte de varilla cerrado x 2

**AB** Tornillo autorroscante M4 x 15 mm x 2

19. Fije los soportes de varilla cerrados (YY) al panel de repisa izquierdo (A) y al panel de repisa derecho (B), y asegúrelos con tornillos para madera M4 x 14 mm (MM). Inserte las varillas de metal de 22 mm (X) en los soportes de varilla abiertos (YY), y asegúrelos con tornillos autorroscantes M4 x 15 mm (AB).

### Aditamentos usados

**MM** Tornillo para madera M4 x 14 mm x 6

**YY** Soporte de varilla abierto x 2

**AB** Tornillo autorroscante M4 x 15 mm x 2

### Instalación del estante ajustable

20. Introduzca los pasadores de estante (II) en el lugar que desee del gabinete. Luego, coloque el estante ajustable (E) sobre la parte superior.

**Nota:** asegúrese de que los pasadores de estante (II) estén nivelados.

### Aditamentos usados

**II** Pasador de estante x 4

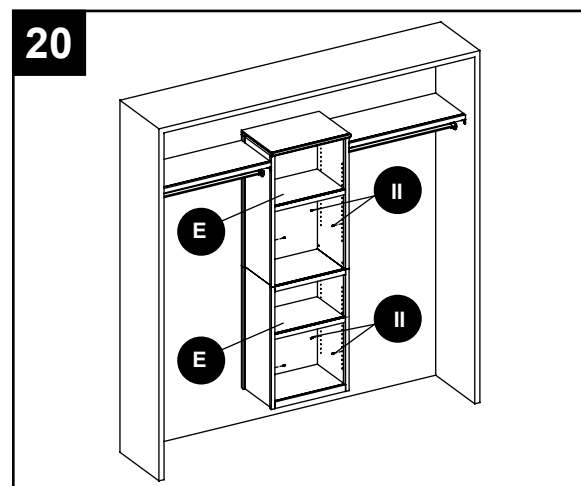
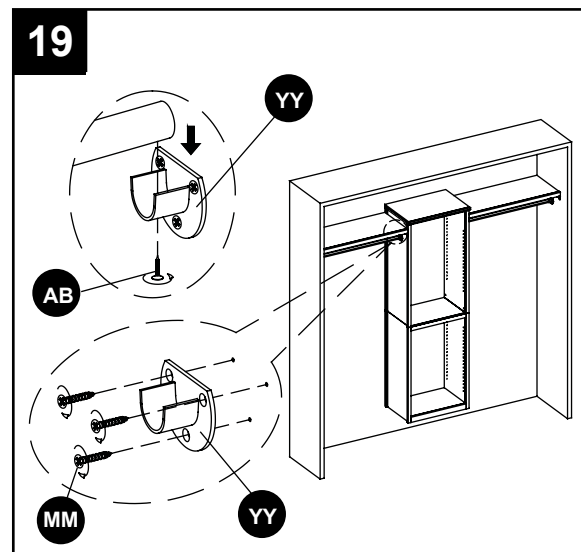
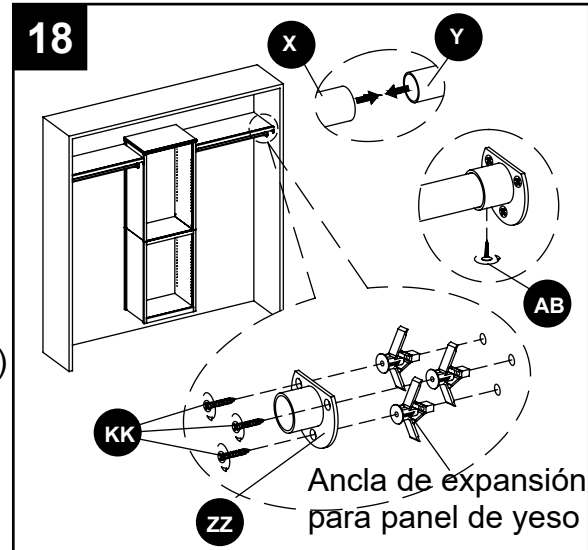

## CUIDADO Y MANTENIMIENTO

- Revise periódicamente para asegurarse de que todos los componentes estén ubicados de forma correcta, no presenten daños y de que estén firmemente conectados.
- Use un paño suave y limpio que no raye la superficie al limpiarla.
- Nunca utilice agua para limpiar los muebles, ya que puede provocar daños en el acabado.
- Limpie con un paño húmedo y un limpiador suave. Seque con un paño limpio.
- En el caso de que el mueble se tiña o se dañe durante el uso, le recomendamos que llame a un profesional para repararlo.
- Mantenga el mueble lejos de la luz solar directa, ya que puede provocar daños en el acabado.
- Es mejor mantener los muebles en un ambiente climatizado. Los cambios extremos de temperatura y de humedad pueden ocasionar decoloración, deformación, contracciones y grietas en la madera.
- Se proporciona un aplicador de retoque (SS) para reparar rasguños o rayones que pueden ocurrir durante el ensamblaje o envío.

## SOLUCIÓN DE PROBLEMAS

PROBLEMA	CAUSA POSIBLE	ACCIÓN CORRECTIVA
Uno de los extremos del estante largo (L) queda flotante.	El espacio del armario mide más de 8 pies/2,44 m.	1. Compre las abrazaderas para estante y las abrazaderas de pared correspondientes (se venden por separado). 2. Cambie el estante largo (V) por uno más largo con acabado y estilo similares.
No puede instalar el estante largo (L) dentro del armario.	El espacio del armario mide menos de 8 pies/2,44 m.	1. Acorte un lado del estante largo (V). Contrate a un remodelador asegurado para la instalación. 2. Cambie el estante largo (V) por uno más corto con un acabado y estilo similares.
El estante está inclinado.	Las abrazaderas de pared y las abrazaderas para repisa no se instalaron al mismo nivel.	Use un nivel de calidad para asegurarse de que las abrazaderas estén niveladas.

## SOLUCIÓN DE PROBLEMAS

PROBLEMA	CAUSA POSIBLE	ACCIÓN CORRECTIVA
Un extremo de la varilla de metal no se puede apoyar correctamente sobre el soporte de varilla abierto (YY).	La abertura del soporte de varilla abierto no apunta hacia arriba en dirección vertical.	Use un nivel de calidad para asegurarse de que el borde plano del soporte de varilla abierto esté nivelado durante la instalación.
El kit de la varilla está inclinado.	Los soportes de varilla abiertos y cerrados no están instalados al mismo nivel.	Use un nivel de calidad para asegurarse de que ambos soportes de varilla queden nivelados.
El tornillo atravesó el panel lateral.	Utilizó un tornillo para madera M4 x 38 mm para instalar el soporte de varilla en el costado del gabinete.	Use tornillos para madera M4 x 14 mm.
La torre del armario está inclinada.	Los listones de colgante para pared no están nivelados.	Vuelva a instalar los listones de colgante para pared y asegúrese de que queden nivelados.
No puede colgar la torre del armario en la pared.	Las ubicaciones de los orificios de montaje no son las correctas.	Vuelva a instalar los listones de colgante para pared; asegúrese de que el espacio entre los dos listones de colgante para pared sea de 39-1/2 pulg/100,33 cm y de que la ubicación de los dos orificios de montaje de la parte inferior no quede a menos de 31-1/2 pulg/80,01 cm del piso.

## GARANTÍA

La garantía de este producto (exclusiva de las repisas) es válida para el comprador original. Si esta unidad presenta alguna falla debido a defectos en los materiales o la mano de obra, el fabricante reemplazará o reparará este artículo sin cargos y a su discreción. La garantía se anula si el producto no se ensambló correctamente y debido al mal uso, abuso por sobrecarga, modificación de cualquier tipo o daños producidos por un accidente. Esta garantía no es transferible y no cubre el desportillado, desprendimiento, rayones, oxidación, abolladuras u otros daños en la superficie de este producto. La responsabilidad del fabricante se limita a la reparación o el reemplazo de este producto. El fabricante no se hará responsable por daños accidentales o resultantes u otros daños o pérdidas causadas por fallas del producto.

Esta garantía reemplaza a todas las demás garantías explícitas. Algunos estados no permiten la exclusión o limitación de los daños accidentales o resultantes, de modo que las limitaciones anteriores pueden no aplicarse en su caso. Esta garantía le otorga derechos legales específicos, y podría tener otros derechos, que varían según el estado.

### LISTA DE PIEZAS DE REPUESTO

Para obtener piezas de repuesto, llame a nuestro Departamento de Servicio al Cliente al 1-866-439-9800, de lunes a viernes de 8 a.m. a 8 p.m., hora estándar del Este.

PIEZA	DESCRIPCIÓN	PIEZA #
A	Panel de repisa izquierdo	*WSLCSCE/G/BW-01-HPL
B	Panel de repisa derecho	*WSLCSCE/G/BW-02-HPR
C	Panel de repisa superior	*WSLCSCE/G/BW-03-HPT
D	Panel de repisa posterior	*WSLCSCE/G/BW-04-HPB
E	Estante ajustable	*WSLCSCE/G/BW-05-AS
F	Panel de base izquierdo	*WSLCSCE/G/BW-06-BPL
G	Panel de base derecho	*WSLCSCE/G/BW-07-BPR
H	Panel de base superior	*WSLCSCE/G/BW-08-BPT
I	Panel de base posterior	*WSLCSCE/G/BW-09-BPB
J	Panel de base inferior	*WSLCSCE/G/BW-10-BPB
K	Listón de colgante para pared	*WSLCSCE/G/BW-11-WHC
L	Estante largo	*WSLCSCE/G/BW-12-LS
W	Plantilla de instalación	*WSLCSCE/G/BW-13-IT
X	Varilla de metal de 22 mm	*WSLCSCE/G/BW-14-22MP
Y	Varilla de metal de 25 mm	*WSLCSCE/G/BW-15-25MP

PIEZA	DESCRIPCIÓN	PIEZA #
AA	Perno	*WSLCSCE/G/BW-16-1 1/4B
BB	Arandela de seguridad	*WSLCSCE/G/BW-17-LW
CC	Arandela plana	*WSLCSCE/G/BW-18-FW
DD	Cerrojo de leva	*WSLCSCE/G/BW-19-CL
EE	Perno de leva pequeño	*WSLCSCE/G/BW-20-SCB
FF	Espiga de madera	*WSLCSCE/G/BW-21-WD
GG	Tornillo para madera M4 x 38 mm	*WSLCSCE/G/BW-22-38WS
HH	Tornillo para madera M4 x 14 mm	*WSLCSCE/G/BW-23-14WS
II	Pasador de estante	*WSLCSCE/G/BW-24-SP
JJ	Tirafondo M8 x 2-1/2 pulg	*WSLCSCE/G/BW-25-2 1/2LB
LL	Arandela plana grande	*WSLCSCE/G/BW-26-LFW
NN	Ancla de expansión de pared	*WSLCSCE/G/BW-27-WA
OO	Abrazadera en L	*WSLCSCE/G/BW-28-LB
PP	Perno de leva grande	*WSLCSCE/G/BW-29-LCB
QQ	Tuerca cilíndrica	*WSLCSCE/G/BW-30-BN
RR	Llave de tuercas Allen M4	*WSLCSCE/G/BW-31-M4AW
SS	Aplicador de retoque	*WSLCSCE/G/BW-32-TUP
MM	Tornillo para madera de zinc M4 x 14 mm	*WSLCSCE/G/BW-33-14ZWS
YY	Soporte de varilla abierto	*WSLCSCE/G/BW-34-OPH
ZZ	Soporte de varilla cerrado	*WSLCSCE/G/BW-35-CPH
AB	Tornillo autorroscante M4 x 15 mm	*WSLCSCE/G/BW-36-15SS
KK	Tornillo de zinc M4 x 38 mm	*WSLCSCE/G/BW-37-38ZS
	Todos los aditamentos	*WSLCSCE/G/BW-38-CH
	Todos los aditamentos juego para el poste	*WSLCSCE/G/BW-39-CHFPK

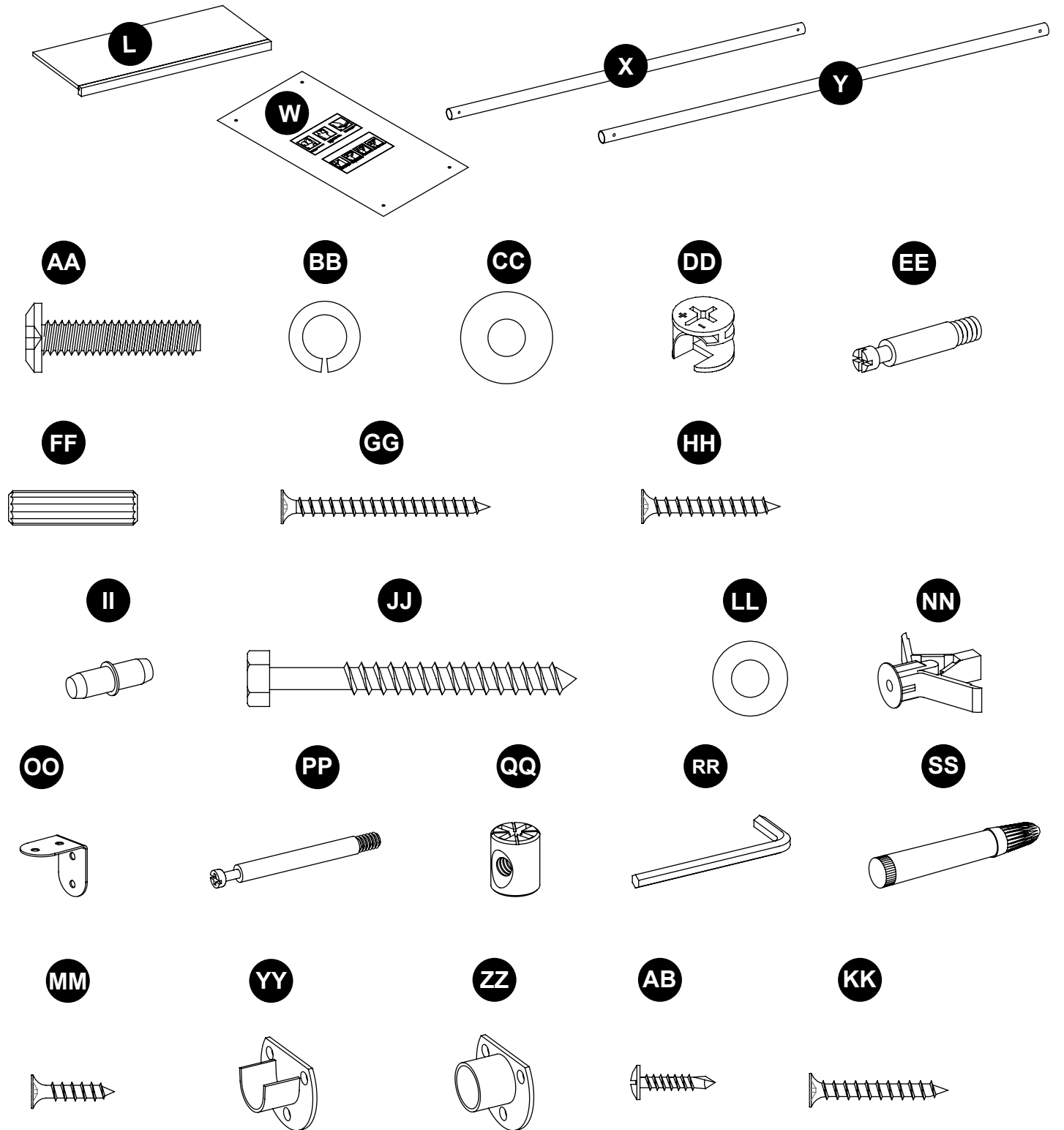
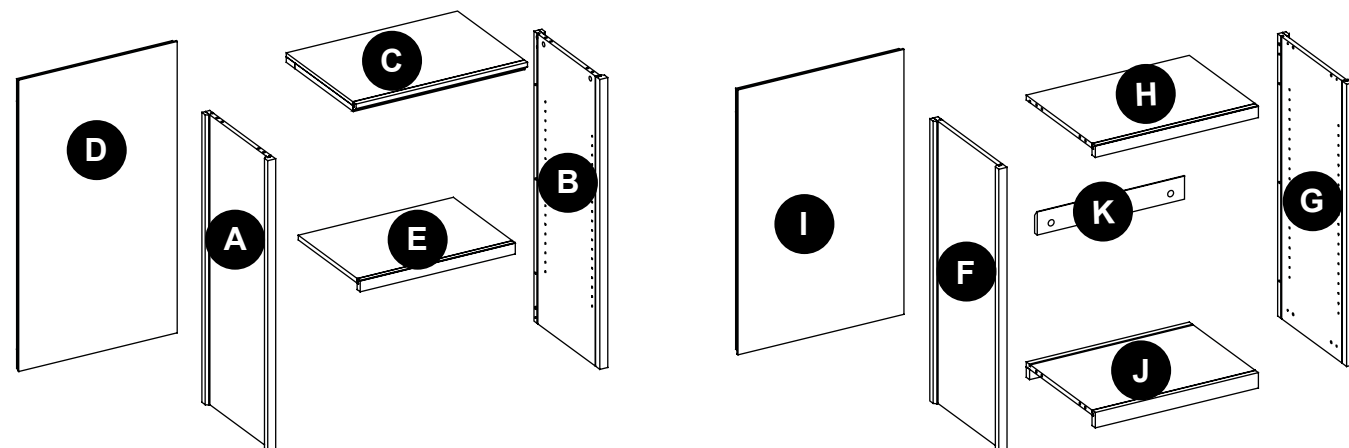

Impreso en Vietnam

Fecha: 2018-03-07 Rev. 0001-A  
# MEIFUR de fábrica

allen + roth® es una marca registrada de LF, LLC.  
Todos los derechos reservados.